

The D. Van Nostrand Company

**intend this book to be sold to the Public
at the advertised price, and supply it to
the Trade on terms which will not allow
of discount.**



PREVIOUSLY PUBLISHED

ELEMENTS OF
PLANE GEOMETRY

With Numerous Exercises

By CHARLES N. SCHMALL and
SAMUEL M. SHACK

12mo - - One-Half Leather - - \$1.25, Net

A
FIRST COURSE
IN
ANALYTICAL GEOMETRY

PLANE AND SOLID WITH NUMEROUS
EXAMPLES

BY
CHARLES N. SCHMALL

AUTHOR OF
"ELEMENTS OF PLANE GEOMETRY"



D. VAN NOSTRAND COMPANY
NEW YORK
1905

7-5 111

QA 551
.S 34

LIBRARY of CONGRESS
Two Copies received
JUN 28 1905
Copyright entry
Nov. 16, 1904
GLASS a XXC No
101821
COPY B.

COPYRIGHT, 1905
BY
C. N. SCHMALL



TABLE OF CONTENTS

PART I

PLANE GEOMETRY

CHAPTER	PAGE
I. CO-ORDINATES. THE POINT	1
II. LOCUS OF AN EQUATION	26
III. EQUATION OF A LOCUS	41
IV. THE STRAIGHT LINE	49
V. THE CIRCLE	86
VI. TRANSFORMATION OF CO-ORDINATES	124
VII. THE PARABOLA	132
VIII. THE ELLIPSE	158
IX. THE HYPERBOLA	194
X. CONFOCAL CONICS	219
XI. GENERAL EQUATION OF THE SECOND DEGREE	230
XII. HIGHER PLANE CURVES	241

PART II

SOLID GEOMETRY

I. THE POINT	275
II. THE PLANE	285
III. THE STRAIGHT LINE	291
IV. SURFACES. SURFACES OF REVOLUTION	298
APPENDIX	312

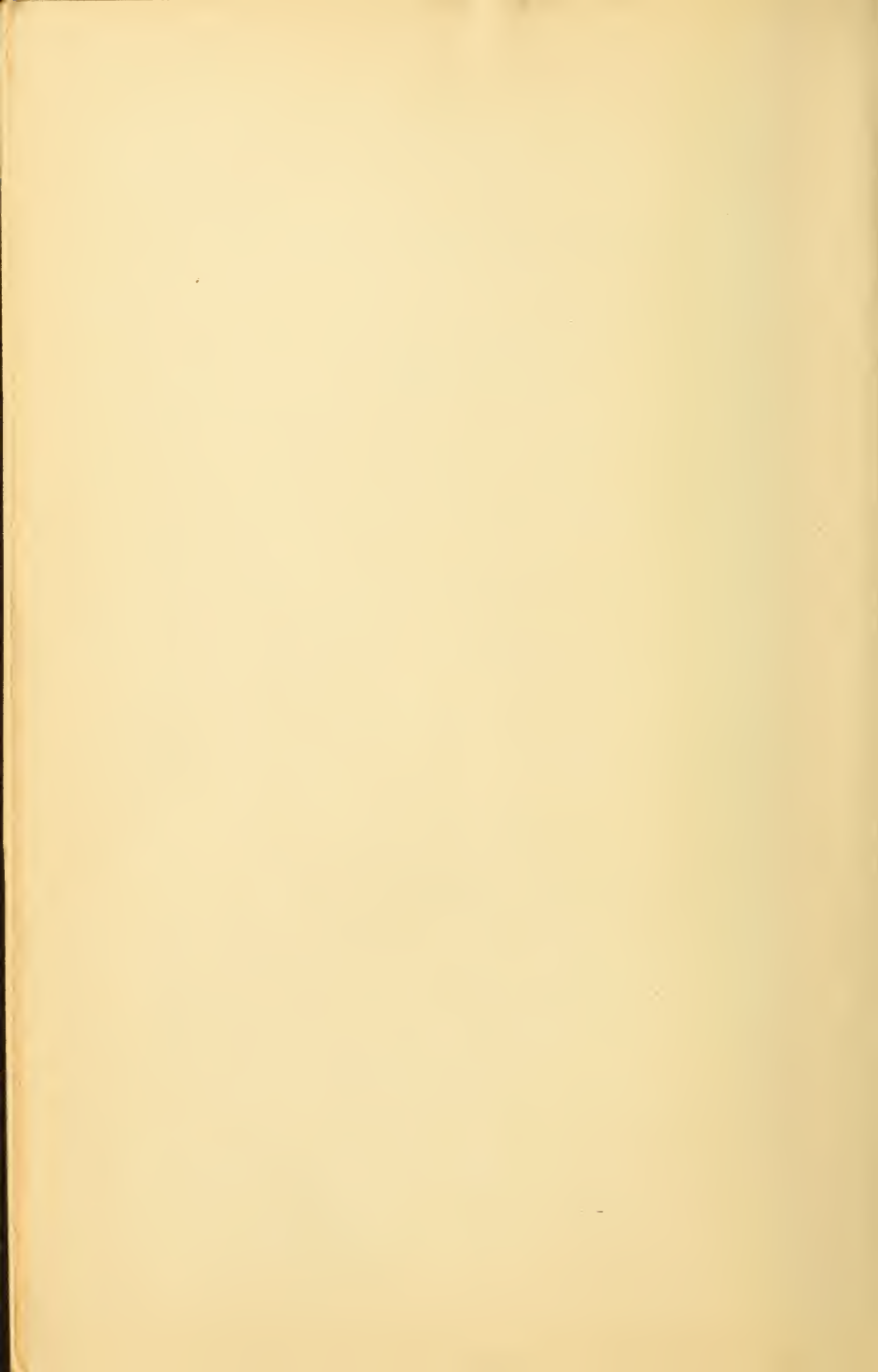

PREFACE

THIS work was designed as a text-book for the use of American colleges and scientific schools. It furnishes a course of moderate scope in Analytical Geometry, well adapted to the needs of these institutions, and supplies an introduction to a more advanced course. Special pains have been taken to give an easy and gradual development of the subject, and to make the book as attractive and interesting to the beginner as the nature of Analytical Geometry would allow. The matter contained is of an elementary character and can be mastered in a few months.

The treatment of every topic involved is simple, direct, and straightforward. Method has been exalted over matter in the effort to inculcate a thorough conception of the spirit of the subject. The object of Analytical Geometry is not so much to derive the properties of the curves investigated as to teach a new method of research; and the student who acquires an insight into the method accomplishes far more than he who memorizes all the known properties of the conics.

Each section or article of the book, while serving as a link in the chain of arguments, is yet a unit in itself, so that the teacher may omit various sections at his discretion without impairing the continuity of the work. Throughout the book there is a variety of method calculated to relieve the monotony sometimes found in similar works. Hackneyed and artificial devices have been scrupulously avoided, and all proofs given are rigorous. Care has been taken to eliminate anything

vague or abstruse. No means have been neglected in the endeavor to make this a model text-book.

The vital difference between this book and similar works is that it does not attempt to perform the duty of both teacher and text-book at the same time. Many recent books contain too much in the way of spoon-feeding, and leave little or nothing for the teacher. Such works, in general, are a failure pedagogically.

The present work presupposes a serviceable knowledge of Elementary Algebra, Geometry, and Trigonometry, and a slight familiarity with the elements of the determinant notation. The elementary properties of determinants are now proved in most books on algebra, and it is not expecting too much of the pupil to be able to use this instrument. Its advantages are well known. The close relations among the above-named branches of mathematics are made very apparent in this book. Sections involving determinants may be conveniently omitted if necessary.

The exercises in the book have been gathered from various sources, but a great many of them are original. They have all been worked out by the author before insertion, in order to test their adaptability, and though some of them may tax the skill of the best students, none are too difficult for a scholar of average ability. The figures are all new and were made by the author particularly for this work.

No specific acknowledgments to other books are given, for although a few foreign works were consulted, the matter drawn upon is largely the common property of all books on this subject, and probably of all mankind.

Among the features of the book, the following are particularly noteworthy:—

(1) The proof of the formulæ for the area of a triangle and a polygon in terms of the co-ordinates of the vertices.

(2) The development of the fundamental relation between an equation and its locus, and *vice versa*.

(3) The use of the determinant wherever profitable to abbreviate the corresponding operations.

(4) The treatment of the equation of the second degree representing two straight lines.

(5) The treatment of the more elegant properties of circles, viz., coaxial circles, centers and circles of similitude, angle of intersection, etc.

(6) The development of the properties of the conic sections. Discussion of the ellipse and hyperbola by means of the eccentric angle, etc.

(7) The chapter on the elementary properties of confocal conics.

(8) The numerous exercises. Among them are some of the most elegant properties of the conics.

Other minor details, too numerous to mention here, are evident on inspecting the book.

The author desires to acknowledge his gratitude to his publishers for their generous and hearty co-operation; and to Messrs. F. H. Gilson Co., of the Stanhope Press, Boston, for the care they have taken to make the typography attractive. Special thanks are due to Professor Oren Root of Hamilton College for valuable suggestions, criticisms, and corrections, after reading the proofs. Dr. Thomas F. Nichols of the same institution also viewed the proof sheets and offered helpful suggestions.

Great precautions were taken to guard against the infiltration of errors, but it is likely that the effort has not been entirely successful. Any corrections will be gratefully received.

C. N. SCHMALL.

NEW YORK, Jan. 2, 1905.

PART I

PLANE GEOMETRY

ANALYTICAL GEOMETRY

CHAPTER I

CO-ORDINATES. THE POINT

1. **Application of Algebra to Geometry.** — Let the student describe a circle of radius, say 5 inches, on any part of the board, and beneath it write the equation $x^2 + y^2 = 25$. We shall now ask the beginner whether he can perceive any possible relation between these two elements (the equation and

the figure). He will ponder, and tax his imagination in a fruitless endeavor to associate them, and will finally reply in the negative.* Now let him draw through the center O two lines $X'X, Y'Y$, \perp to each other. $[x^2 + y^2 = 25.]$

From any point P on the circumference, drop the \perp PA, PB to $X'X$, and

$Y'Y$ respectively. The beginner will now notice that the diagonal of the rectangle formed is constant and always

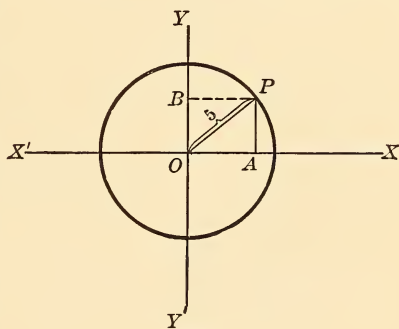

Fig. 1.

* He will undoubtedly have a little prejudice in favor of the existence of some relation though he may be unable to describe it. This manner of introducing the study to the beginner will arouse his interest and curiosity and produce good results.

equal to 5, no matter at which point of the circumference P is. Let $PB = OA$, be denoted by x , and PA by y . Then, for any point P on the circumference we have the relation $x^2 + y^2 = (\text{radius})^2 = 25$. The beginner will now see that it is possible to represent a circle by an equation as above. It is the object of Analytical Geometry to show that geometrical figures (lines, circles, etc.) may be represented by appropriate equations, and that their relations and properties can be conveniently investigated through the agency of these equations.*

2. Co-ordinates.— For convenience, all points in a plane are referred to a pair of intersecting straight lines, generally perpendicular to each other, as in the foregoing illustration.

These lines are termed the **axes of co-ordinates** or simply the **axes**. A point is completely determined by the lengths of the two lines drawn through it parallel to the two axes respectively; or when the axes are rectangular, *i. e.* \perp to each other, a point is known when its distances from the axes are given. These distances are known as the **co-ordinates** of the point.

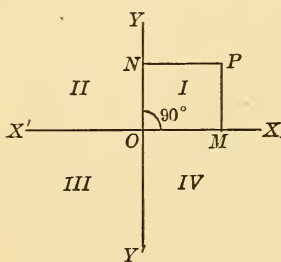

Fig. 2a.

Thus, in Fig. 2a, the point P is determined if its distances PM, PN, from the axes are known. In Fig. 2b, it is determined if the lines PN, PM, drawn parallel to the axes, and the angle ϕ between the axes, are given; X'X is called the **axis of abscissas**, or the **x-axis**; Y'Y, the **axis of ordinates**, or **y-axis**. The line PN, measured parallel to the

* We shall not attempt to give at present a full definition of the subject.

“The satisfactory definition of any science is often one of the latest and most difficult achievements of that science.” — Ladd's *Psychology*.

x -axis, is the abscissa or x of the point P . The line PM , measured parallel to the y -axis, is the ordinate or y of P . The point O , where the axes meet, is called the **origin**. The axes divide the plane into four compartments called **quadrants**. The quadrants are designated by numbers, as in Fig. 2a. A

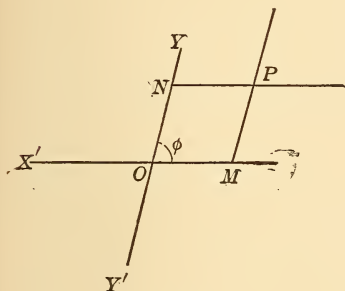

Fig. 2b.

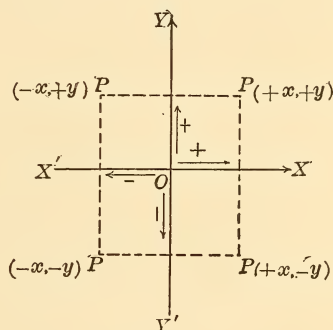

Fig. 2c.

point is designated by its co-ordinates, abscissa first, ordinate next; *e. g.*, the point (x, y) , the point (h, k) , point (a, b) , etc.

3. Convention of Signs.—If distances measured in one direction on a straight line are defined as **positive**, those in



Fig. 3.

the opposite direction are **negative**. Thus if A and B are two points, AB means the distance between the two points and also implies that it is measured to the right from A to B . Thus $AB = -BA$, $AC = -CA$, $AC + CB = AB$, $-BC - CA = -BA = AB$. This convention of signs is arbitrary, and is applied to the four quadrants in the following manner:—Dis-

tances measured along the x -axis, or parallel to it, from $Y'Y$ to the right, are defined as positive; to the left, negative. Distances measured along the y -axis, or parallel to it, are positive when measured upward and negative when measured downward. Thus a point (x, y) whose abscissa is x , and ordinate y , may have four positions depending upon the signs of its co-ordinates. This is clearly shown in Fig. 2c. Hence, the signs of the co-ordinates must also be given to fix a point. The co-ordinates of the origin are obviously $(0, 0)$. The co-ordinates of a point are generally taken according to some convenient unit of length.*

4. Plotting Points.—To plot a point is to locate it. Thus, to plot the point $(9, 2)$ we measure 9 units of length along OX to the right, then two units upward, parallel to OY . Similarly, the point $(-3, -5)$ is found by measuring 3 units along OX to the left and then 5 units downward, parallel to OY' .

EXERCISES.

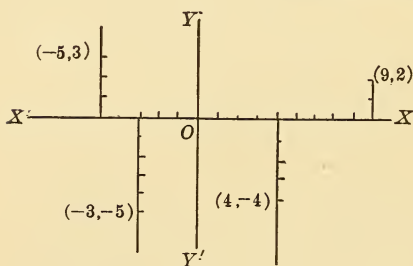

Fig. 4.

1. (1) Plot the following points :

$(3, -2)$, $(6, -9)$, $(-2, 4)$,
 $(-5, -3)$, $(4, 6)$ (h, k).

(2) The following points :
 $(7, 4)$, $(0, 1)$, $(3, 0)$, $(-2, 0)$,
 $(0, -7)$, $(2, 3\frac{1}{2})$, $(-\frac{1}{2}, -\frac{5}{2})$, $(6, -\frac{1}{2})$.

NOTE. — Take $\frac{1}{2}$ as the unit.

2. Construct the Δ whose vertices are the points $(0, 0)$, $(3, 0)$, $(5, 9)$.

* The teacher should early explain the use of "co-ordinate paper."

3. Construct the polygon whose vertices are the points $(0, -2)$, $(1, -1)$, $(-1, -1)$, $(-1, 0)$, $(2, 0)$, $(1, 1)$.
4. Two vertices of an equilateral Δ are the points $(a, 0)$, $(-a, 0)$; find the co-ordinates of the third vertex. *Ans.* $(0, a\sqrt{3})$.
5. What is the direction, with respect to the x -axis, of the line joining the points $(2, 3)$, $(-6, 3)$; the points $(4, 6)$, $(4, -7)$; the points $(2, 4)$, $(6, 8)$; the points $(0, 0)$, $(2, 2)$; the points $(3\sqrt{3}, 3)$, $(0, 0)$?
6. What kind of quadrilateral is formed for the points $(0, 0)$, $(a, 0)$, (a, b) , $(0, b)$.
7. The diagonals of a square whose center is at the origin coincide with the axes. If its side is a , find the co-ordinates of its vertices.
8. Two vertices of a square are $(a, 0)$, $(b, 0)$ where $b > a$; find the remaining vertices.
9. What kind of a quadrilateral is formed by the points $(6, 0)$, $(7, 3)$, $(2, 0)$, $(3, 3)$.

NOTE. — Examine the lengths of the sides.

10. Find the length of the line from the origin to the point $(3, 4)$.

5. Polar Co-ordinates. — In rectangular co-ordinates we determined a point by its distances from the axes. We can, however, fix a point by polar co-ordinates, in which we take account of its distance from a given fixed point, called the **pole**, and its direction from a fixed line called the **polar axis** or **initial line**. Thus, let O be the pole, and OX the initial line; now let OX revolve about O until it passes through P . Then the point P is known if the angle θ and the distance OP , called the **radius vector** are known. These together con-

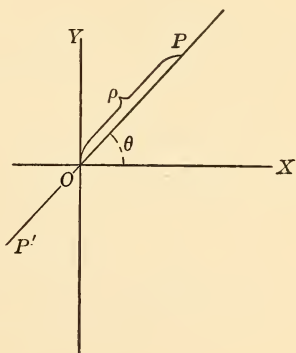

Fig. 5.

stitute the polar co-ordinates of the point P. The radius vector is usually denoted by the Greek letter ρ , and the point P is designated in polar co-ordinates by (ρ, θ) . The **vectorial angle** θ is positive or negative according as we suppose the line OP to revolve in the counter-clockwise or clockwise direction. The radius vector ρ is positive if measured from O along the revolving line OP, and negative if measured in the opposite direction, along OP'. Thus the points $(-3, 180^\circ)$, $(2, 90^\circ)$, $(3, -120^\circ)$, $(3, 30^\circ)$, $(4, 180^\circ)$ are represented by A, B, C, D, and E respectively in the figure.

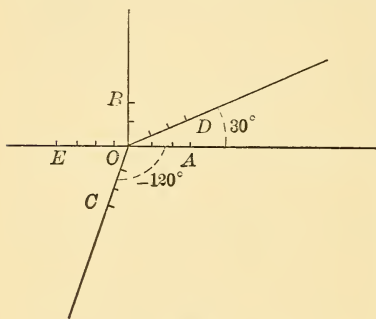

Fig. 6.

EXERCISES.

- (1) Plot the points $(4, 60^\circ)$, $(3, -180^\circ)$, $(60^\circ, -2)$.
 (2) The points, $(5, -300^\circ)$, $(3, 360^\circ)$, $(1, -30^\circ)$ $(-2, -60^\circ)$.
- Plot the points $(3, 60^\circ)$, $(-3, 240^\circ)$, $(3, -300^\circ)$ $(-3, -120^\circ)$.
- What line is represented by $\theta = 30^\circ$? What is represented by $\rho = 2$?
- Plot the points $(4, 150^\circ)$, $(-5, -170^\circ)$, $(-1, 330^\circ)$.
- Plot the points $(-a, 45^\circ)$, $(180^\circ, 0)$, $(0, 30^\circ)$, $(-2, 0^\circ)$, $(-a, -30^\circ)$, $(3a, -90^\circ)$, $(2a, \tan^{-1} 2)$, $(a, \tan^{-1} \frac{1}{4})$, $(b, \tan^{-1} \frac{1}{3})$, $(30^\circ, -3)$, $(-3, 0^\circ)$, $(240^\circ, 5)$.

NOTE. — It is immaterial whether the vectorial angle, or the radius vector is read first.

6. Transformation from Rectangular to Polar Co-ordinates, and Vice Versa.

CASE I. When the polar axis coincides with the x -axis and the pole is at the origin. Let P be the point (x, y) in rectangular co-ordinates and (ρ, θ) in polar co-ordinates.

Then from rt. $\triangle POQ$,

$$\left. \begin{aligned} x &= \rho \cos \theta \\ y &= \rho \sin \theta \end{aligned} \right\} [x \text{ and } y \text{ in terms of } \rho, \theta].$$

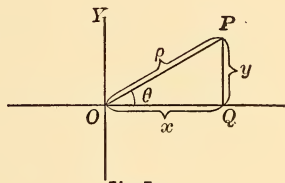

Fig. 7.

CASE II. Pole at point (a, b) , polar axis parallel to x -axis.

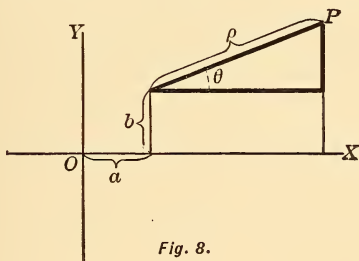

Fig. 8.

This gives

$$\left. \begin{aligned} x &= a + \rho \cos \theta \\ y &= b + \rho \sin \theta \end{aligned} \right\}$$

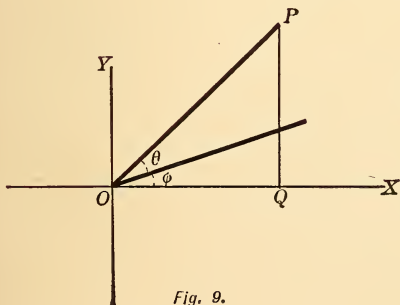

Fig. 9.

CASE III. Pole at origin; polar axis makes an angle ϕ with x -axis.

Here we get

$$\left. \begin{aligned} x &= \rho \cos (\theta + \phi), \\ y &= \rho \sin (\theta + \phi). \end{aligned} \right\}$$

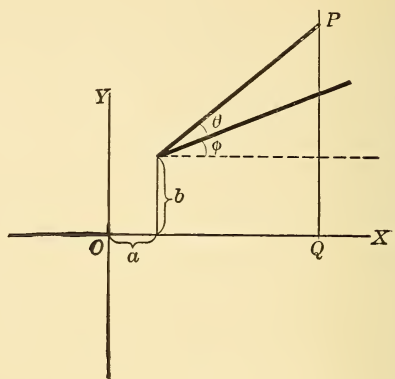

Fig. 10.

CASE IV. If in Case III the pole is at point (a, b) , we get:—

$$\begin{aligned}x &= a + \rho \cos (\theta + \phi), \\y &= b + \rho \sin (\theta + \phi).\end{aligned}$$

Reversing the process, we get:—

CASE I. $\rho = \sqrt{x^2 + y^2}$, $\tan \theta = \frac{y}{x}$, or $\theta = \tan^{-1} \frac{y}{x}$.

CASE II. $\rho = \sqrt{(x-a)^2 + (y-b)^2}$, $\theta = \tan^{-1} \frac{y-b}{x-a}$.

CASE III. $\rho = \sqrt{x^2 + y^2}$, $\theta = \tan^{-1} \frac{y}{x} - \phi$.

CASE IV. By the student.

7. Radian or Circular Measure of an Angle.— In Higher Mathematics an angle is measured by the quotient of its arc by its radius. The unit is the **radian**, which is an angle whose arc is equal to its radius. Hence, any angle = $\left(\frac{\text{arc}}{\text{radius}}\right)$ radians.

$$\therefore 360^\circ = 2\pi r \div r = 2\pi \text{ radians, or simply } 2\pi,$$

$$\therefore 180^\circ = \pi \text{ radians,}$$

whence 1 radian = $\frac{180^\circ}{\pi} = \frac{180^\circ}{3.1416} = 57^\circ 17' 45''$ nearly.

EXERCISES.

(1) Express in radians, these angles :

$1^\circ, 30^\circ, 45^\circ, 60^\circ, 90^\circ, 180^\circ, 270^\circ.$

Ans. $\frac{\pi}{180}, \frac{\pi}{6}, \frac{\pi}{4}, \frac{\pi}{3}, \frac{\pi}{2}, \pi, \frac{3}{2}\pi.$

(2) Express in radians : $70^\circ, 80^\circ, 220^\circ, 135^\circ,$ etc.

8. The distance between two points.

CASE I. Rectangular co-ordinates.

$A(x_1, y_1)$ and $B(x_2, y_2)$

are the two given points.

Draw the ordinates $AE, BD.$

Draw $AC \perp BD.$

Then $\overline{AB}^2 = \overline{AC}^2 + \overline{BC}^2,$

$\therefore d = \sqrt{(x_2 - x_1)^2 + (y_2 - y_1)^2}.*$

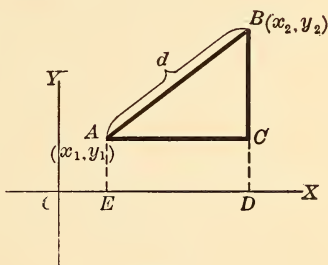

Fig. 11.

CASE II. Oblique axes.

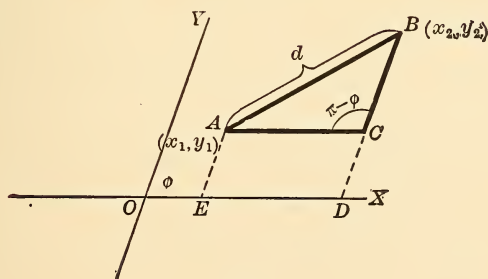

Fig. 12.

* The beginner should take other cases where the points lie in different quadrants and convince himself that these formulæ are general.

Draw the ordinates AE, BD, and AC \parallel OX.

Then $\overline{AB}^2 = \overline{AC}^2 + \overline{BC}^2 - 2 \cdot AC \cdot BC \cdot \cos ACB$,

$$\therefore d = \sqrt{(x_2 - x_1)^2 + (y_2 - y_1)^2 + 2(x_2 - x_1)(y_2 - y_1) \cos \phi}.$$

If one point, say A, is at the origin, we have:—

CASE I. $d = \sqrt{x_2^2 + y_2^2}$.

CASE II. $d = \sqrt{x_2^2 + y_2^2 + 2x_2y_2 \cos \phi}$.

CASE III. Polar co-ordinates.

A (ρ_1, θ_1) and B (ρ_2, θ_2) are the given points.

Then $\overline{AB}^2 = \overline{OA}^2 + \overline{OB}^2 - 2 \cdot OA \cdot OB \cdot \cos (\theta_2 - \theta_1)$.

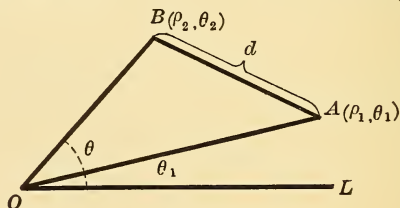

Fig. 13.

$$\therefore d = \sqrt{\rho_1^2 + \rho_2^2 - 2 \rho_1 \rho_2 \cos (\theta_2 - \theta_1)}.*$$

EXERCISES.

- 1 Find the distance between the points $(4, -5)$, $(-3, 6)$.

$$\begin{aligned} d &= \sqrt{[4 - (-3)]^2 + [-5 - (+6)]^2} \\ &= \sqrt{7^2 + 11^2} \\ &= \sqrt{170}. \end{aligned}$$

2. Find a point equidistant from the three points $(8, -2)$, $(3, 5)$, $(3, -4)$.

SUGGESTION. — Let (x, y) be the point.

Then $(x - 8)^2 + (y + 2)^2 = (x - 3)^2 + (y - 5)^2 = (x - 3)^2 + (y + 4)^2$,
whence x and y can be found.

* The most important formulæ in this work are printed in bold-face type.

3. Find the condition that the point (h, k) may be at a distance of five from the point $(7, 9)$.

SUGGESTION. — $(5)^2 = (h - 7)^2 + (k - 9)^2$.

4. Express the condition that (h, k) may be equidistant from the points $(4, 5)$, $(-6, 8)$.

5. Find the length from $(2, -3)$ to $(4, 7)$.

6. Show that the points $(1, 2)$, $(1, 6)$, $(\sqrt{12} + 1, 4)$, are the vertices of an equilateral Δ whose side equals 4.

7. Three vertices of a parallelogram are $(1, 0)$, $(4, 3)$, $(1, 2)$. Find the fourth vertex.

8. Plot the points $(-3, -\pi)$, $(7, -135^\circ)$, $(5, \frac{5}{4}\pi)$, $(0, -\frac{2}{3}\pi)$.

9. Find the distance from origin to $(3, 4)$.

10. Find the distance from $(1, 2)$, $(-5, 4)$ axes inclined at 60° .

11. Distance between $(3, \frac{\pi}{3})$, $(-\frac{\pi}{2}, 5)$.

12. Distance from origin to $(-9, -6)$.

13. Distance between $(-4, 6)$ and $(2, 3)$.

14. Find the sides of the Δ whose vertices are $(2, 3)$, $(4, -5)$, $(-3, -6)$.

15. Express that (a, b) is at a distance of 15 from $(2, -5)$.

16. Express that (x, y) is equidistant from (o, b) , (a, o) .

17. Distance from origin to $(2, 3)$, $(-2, -3)$, $(-2, 3)$, is $\sqrt{13}$.

18. Show that the sides of the Δ $(-1, -2)$, $(1, 2)$, $(2, -3)$, are respectively $\sqrt{20}$, $\sqrt{10}$, $\sqrt{26}$.

19. Show that the Δ $(1, 1)$, $(-1, -1)$, $(-\sqrt{3}, \sqrt{3})$ is equilateral.

20. Express that (x, y) is equidistant from $(-1, 1)$ $(2, 3)$.

21. Show that these points form a square: $(-4, 3)$, $(2, 1)$, $(0, 3)$, $(2, 5)$.

22. Plot the point $(5, 2k\pi + \frac{\pi}{6})$, where k is any integer.

23. Transform these points to polar co-ordinates: $(-1, 1)$, $(-1, 2)$, $(-3, 3)$ $(-4, -4)$.

Ans. $(\sqrt{2}, \frac{\pi}{4})$, $(\sqrt{5}, -\tan^{-1} 2)$, $(3\sqrt{2}, \frac{3}{4}\pi)$, $(4\sqrt{2}, \frac{5}{4}\pi)$.

24. Transform these points to rectangular co-ordinates —

$(3, \frac{\pi}{4})$, $(3, -\frac{\pi}{3})$, $(-3, \frac{2}{3}\pi)$, $(-3, -\frac{\pi}{4})$.

Ans. $(\frac{3}{2}\sqrt{2}, \frac{3}{2}\sqrt{2})$ $(\frac{3}{2}, -\frac{2}{3}\sqrt{3})$ $(\frac{3}{2}, -\frac{3}{2}\sqrt{3})$, $(-\frac{3}{2}\sqrt{2}, \frac{3}{2}\sqrt{2})$.

25. Find the distance from the origin to $(-2, -4)$ axes at 60° .

DIVISION OF A LINE.

9. To divide the line joining two points $(x_1, y_1), (x_2, y_2)$ in a given ratio $m:n$.

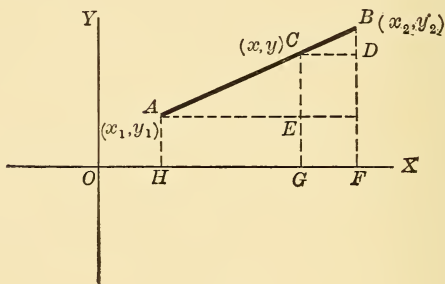

Fig. 14.

A and B are the given points, C, (x, y) is the required point. Draw the ordinates as in the figure.

Now by similar Δ ,
$$\frac{AE}{CD} = \frac{AC}{CB} = \frac{m}{n} \dots \dots \dots (1)$$

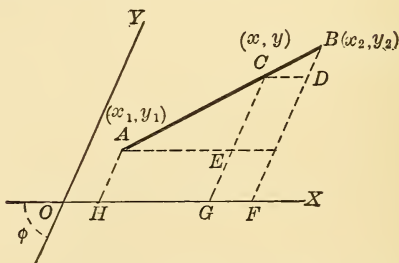

Fig. 15.

In like manner,
$$\frac{EC}{DB} = \frac{m}{n} \dots \dots \dots (2)$$

Substituting co-ordinates in (1) and (2) we get,

$$\frac{x - x_1}{x_2 - x} = \frac{m}{n}, \quad \frac{y - y_1}{y_2 - y} = \frac{m}{n},$$

whence
$$x = \frac{mx_2 + nx_1}{m + n}, \quad y = \frac{my_2 + ny_1}{m + n} . *$$

Again, If AB be divided externally at C, so that

$$AC : BC :: m : n,$$

Then $AC : CB :: m : -n$ [since $BC = -CB$].

Hence, by changing n to $-n$ above, we get the required formulæ for external division, viz. :

$$x = \frac{mx_2 - nx_1}{m - n},$$

$$y = \frac{my_2 - ny_1}{m - n} . *$$

10. To bisect the line joining two given points (x_1, y_1) , (x_2, y_2) .

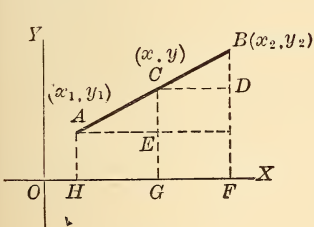

Fig. 16.

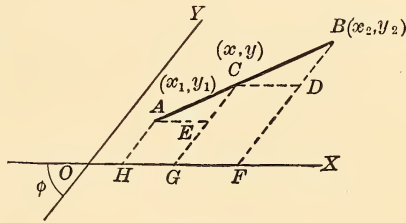

Fig. 17.

Let C be the required point of bisection.

Draw the ordinates and \parallel s as in figure.

Now $AC = CB$ [by construction].

$$\therefore AE = CD, \quad EC = DB.$$

$$\therefore x - x_1 = x_2 - x \quad (1)$$

$$y - y_1 = y_2 - y \quad (2)$$

* The beginner should prove the generality of these formulæ.

Then from (1) and (2)

$$\left. \begin{aligned} x &= \frac{x_1 + x_2}{2} \\ y &= \frac{y_1 + y_2}{2} \end{aligned} \right\} \text{which are the co-ordinates of the point of bisection.}$$

NOTE.—These formulæ can be obtained from the preceding article by putting $m = n = 1$.

EXERCISES.

1. Show that the diagonals of a parallelogram bisect each other.

SUGGESTION.—Take two adjacent sides as axes. Find the mid-points for both diagonals, which will be identical.

2. Show that the line joining the mid-points of two sides of a triangle is equal to half the third side.

3. In the quadrilateral ABCD show that the lines joining the mid-points of the opposite sides, and the line joining the mid-points of the diagonals meet in the point P whose co-ordinates are

$$\begin{aligned} x &= \frac{1}{4} [x_1 + x_2 + x_3 + x_4], \\ y &= \frac{1}{4} [y_1 + y_2 + y_3 + y_4]. \end{aligned}$$

4. Show that the co-ordinates of the center of gravity of the triangle (x_1, y_1) , (x_2, y_2) , (x_3, y_3) are,

$$\begin{aligned} x &= \left[\frac{1}{3} (x_1 + x_2 + x_3) \right], \\ y &= \left[\frac{1}{3} (y_1 + y_2 + y_3) \right]. \end{aligned}$$

5. Find the lengths of the medians of the Δ whose vertices are $(-1, -1)$, $(2, 3)$, $(0, 2)$.

6. Show that the mid-point of the hypotenuse of a right Δ is equidistant from the vertices.

SUGGESTION.—Take the legs of the Δ as axes. Find co-ordinates of mid-point of hypotenuse, etc.

7. Find the point which divides the line joining $(-4, 5)$ and $(11, -4)$ in the ratio of 1 : 2. Ans. (1, 2).

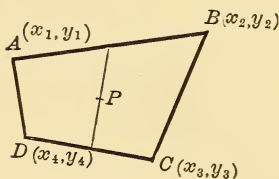

Fig. 18.

8. Three vertices of a square are (1, 9), (5, 6), (2, 2), find the fourth vertex. *Ans.* (- 2, 5).

9. The mid-point of a line is (6, 4) ; one end is (5, 7), find the other end. *Ans.* (7, 1).

10. Find the point of bisection between (2*a*, 2*b*), (*h*, *k*).

11. Find the point half-way between (5, 8), (- 3, - 6).

12. Find the point which divides the distance between (2, 4), (5, - 9) in the ratio of 3 : 4.

13. Find the points of trisection between the origin and (8, 10).

14. Two points are A, (4, 1) and B, (9, 8). Find C so that (1) BC = AB, (2) BC = 2 AB.

NOTE. — A, B, C, must lie on one line.

11. Area of the triangle $(x_1, y_1), (x_2, y_2), (x_3, y_3)$.

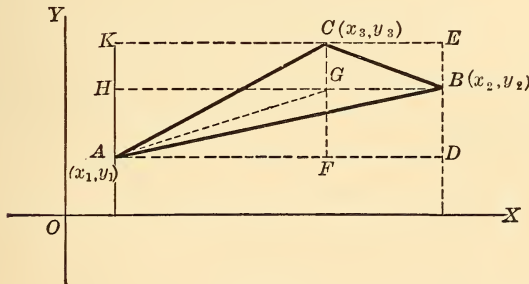

Fig. 19.

ABC is the given Δ . The directions of the various lines in the figure are easily seen.

$$\begin{aligned}
 \text{Now, } \Delta ABC &= \Delta ABG + \Delta ACG + \Delta BCG, \\
 &= \frac{1}{2} \square FDBG + \frac{1}{2} \square HGCK + \frac{1}{2} \square CGBE, \\
 &= \frac{1}{2} [\square ADEK - \square AFGH], \\
 &= \frac{1}{2} [AD \times AK - AF \times AH], \\
 &= \frac{1}{2} [(x_2 - x_1)(y_3 - y_1) - (x_3 - x_1)(y_2 - y_1)], \\
 &= \frac{1}{2} [x_1(y_2 - y_3) - y_1(x_2 - x_3) + x_2y_3 - x_3y_2],
 \end{aligned}$$

$$= \frac{1}{2} \begin{vmatrix} x_1 & y_1 & 1 \\ x_2 & y_2 & 1 \\ x_3 & y_3 & 1 \end{vmatrix} *$$

COR. 1. If one vertex, say A, is at the origin, the area becomes

$$\frac{1}{2} \begin{vmatrix} 0 & 0 & 1 \\ x_2 & y_2 & 1 \\ x_3 & y_3 & 1 \end{vmatrix} = \frac{1}{2} (x_2 y_3 - x_3 y_2).$$

COR. 2. If the three points A, B, C, lie on a straight line, the area of $\triangle ABC$ is zero. Hence the condition that three points (x_1, y_1) , (x_2, y_2) , (x_3, y_3) may be collinear, is

$$\begin{vmatrix} x_1 & y_1 & 1 \\ x_2 & y_2 & 1 \\ x_3 & y_3 & 1 \end{vmatrix} = 0.$$

COR. 3. If the axes are oblique at an angle ϕ , we have

$$\begin{aligned} \triangle ABC &= \frac{1}{2} [\text{ADEK} - \text{AFGH}], \\ &= \frac{1}{2} [\text{AD} \times \text{AK} \sin \phi - \text{AF} \times \text{AH} \sin \phi], \end{aligned}$$

$$\therefore \triangle ABC = \frac{1}{2} \sin \phi \begin{vmatrix} x_1 & y_1 & 1 \\ x_2 & y_2 & 1 \\ x_3 & y_3 & 1 \end{vmatrix}$$

12. Area of the \triangle when the polar co-ordinates of its vertices are given.

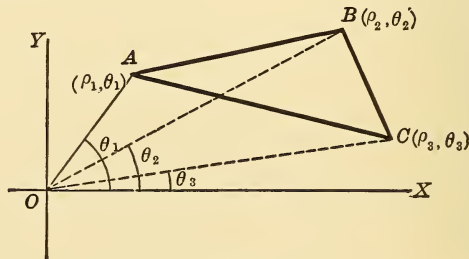

Fig. 20.

A, B, C are the vertices, denoted respectively by (ρ_1, θ_1) , (ρ_2, θ_2) , (ρ_3, θ_3) .

* The beginner should establish the generality of this formula.

$$\triangle ABC = \triangle OAB + \triangle OBC - \triangle OAC.$$

$$\begin{aligned} \text{Area } \triangle OAB &= \frac{1}{2} OA \cdot OB \cdot \sin AOB, \\ &= \frac{1}{2} \rho_1 \rho_2 \sin (\theta_1 - \theta_2). \end{aligned}$$

$$\triangle OBC = \frac{1}{2} \rho_2 \rho_3 \sin (\theta_2 - \theta_3).$$

$$\begin{aligned} \triangle OAC &= \frac{1}{2} \rho_3 \rho_1 \sin (\theta_1 - \theta_3), \\ &= -\frac{1}{2} \rho_3 \rho_1 \sin (\theta_3 - \theta_1), \end{aligned}$$

$$\therefore \triangle ABC = \frac{1}{2} [\rho_1 \rho_2 \sin (\theta_1 - \theta_2) + \rho_2 \rho_3 \sin (\theta_2 - \theta_3) + \rho_3 \rho_1 \sin (\theta_3 - \theta_1)].$$

NOTE. — The order of the suffixes is cyclic.

EXERCISES.

1. Find area of $\triangle (0, 0), (2, 3), (4, -5)$. *Ans.* 11.

2. Show that the area of a $\triangle = \pm \frac{1}{2} \begin{vmatrix} x_1 & y_1 & 1 \\ x_2 & y_2 & 1 \\ x_3 & y_3 & 1 \end{vmatrix}$

the upper or lower sign being used according as we traverse the periphery of the \triangle in the counter-clockwise or clockwise direction.

3. Find the area of the $\triangle (1, 2), (-2, 3), (5, 6)$. *Ans.* — 16. Construct the \triangle and by Ex. 2, account for the minus sign.

4. Find the areas of these \triangle s;

(1) $(8, 3), (-2, 3), (4, -5)$. *Ans.* 40.

(2) $(2, -5), (2, 8), (-2, -5)$. *Ans.* 26.

(3) $(a, b), (b, a), (c, c)$. *Ans.* $\frac{1}{2}(a-b)(a+b-2c)$.

(4) of the quadrilateral $(0, 0), (5, 0), (9, 11), (0, 3)$. *Ans.* 41.

5. Find the area of the $\triangle (11, 9), (6, -2), (-5, 3)$. *Ans.* 73.

6. G is the centroid of $\triangle ABC$; O is any other point; prove,

$$\overline{OA}^2 + \overline{OB}^2 + \overline{OC}^2 = \overline{GA}^2 + \overline{GB}^2 + \overline{GC}^2 + 3\overline{GO}^2.$$

7. Three vertices of a square are $(0, -1), (2, 1), (0, 3)$; find the fourth vertex. *Ans.* $(-2, 1)$.

8. Show that these three points are collinear :

$$(a, b), (b, a), (3a - 2b, 3b - 2a).$$

9. Find the area of the $\triangle (o, o), (a, o), (o, b)$.

10. If the angle between the axes is 30° , find the perimeter of $\triangle (2, 2), (-7, -1), (-1, 5)$.

$$\text{Ans. } 3\sqrt{10+3\sqrt{3}} + 6\sqrt{2+\sqrt{3}} + 3\sqrt{2-\sqrt{3}}.$$

EXERCISES FOR ADVANCED STUDENTS.

1. Show that the condition that the point (x, y) may lie within the Δ $(x_1, y_1), (x_2, y_2), (x_3, y_3)$ is that the following three determinants shall have the same sign :

$$\begin{vmatrix} x & y & 1 \\ x_1 & y_1 & 1 \\ x_2 & y_2 & 1 \end{vmatrix}, \begin{vmatrix} x & y & 1 \\ x_2 & y_2 & 1 \\ x_3 & y_3 & 1 \end{vmatrix}, \begin{vmatrix} x & y & 1 \\ x_3 & y_3 & 1 \\ x_1 & y_1 & 1 \end{vmatrix}.$$

SUGGESTION.—Take the point inside, join it to the three vertices. Then area of given Δ = sum of three determinants. Now take the point outside, obtain area of Δ . Compare the two results, etc.

2. A, B, C, are collinear points ; P is any fourth point on this line. Prove :

$$\overline{PA}^2 \cdot BC + \overline{PB}^2 \cdot CA + \overline{PC}^2 \cdot AB + AB \cdot BC \cdot CA = 0.$$

3. Find area of Δ $(ax_1^2, 2ax_1), (ax_2^2, 2ax_2), (ax_3^2, 2ax_3)$.

$$\text{Ans. } a^2 (x_1 - x_2) (x_2 - x_3) (x_3 - x_1).$$

4. Prove Ex. 2 if P is not on the line ABC.

5. AB, AC are the adjacent sides of a \sphericalangle ABDC ; AD a diagonal. If the sign of an area is positive or negative according as its periphery is gone over in the counter-clockwise or clockwise direction, and P is any point in the plane of the \sphericalangle ,

$$\text{Prove : } \quad \Delta PAD = \Delta PAC + \Delta PAB.$$

6. O is the pole, A and B are the points (ρ_1, θ_1) and (ρ_2, θ_2) respectively. Find the polar co-ordinates of the point of intersection of AB with the bisector of the angle AOB.

$$\text{Ans. } \rho = \frac{2\rho_1\rho_2}{\rho_1 + \rho_2} \cos \frac{1}{2}(\theta_2 - \theta_1)$$

$$\theta = \frac{1}{2}(\theta_2 + \theta_1)$$

SUGGESTION.—Employ the theorem of elementary geometry concerning the bisector of an angle and the proportionality of the segments of the base to the including sides, etc.

7. P is the mid-point of the base BC of the Δ ABC. Prove analytically that

$$\overline{AB}^2 + \overline{AC}^2 = 2\overline{PA}^2 + 2\overline{PB}^2.$$

13. **Digression on Elementary Geometry.** — The analytic method of investigation, *i. e.*, referring a figure to two fixed intersecting lines as co-ordinate axes, and studying its properties by Algebraic Analysis, was first introduced by Descartes in his *Géométrie* in 1637. Before his time, however, algebra had already been applied to the solution of geometrical problems somewhat after the manner of the following examples.*

1. Given $OA = a$, $OB = b$, $OC = c$, the three lines drawn from the center O of an inscribed \odot to the vertices of the $\triangle ABC$; to find the radius OF of the \odot .

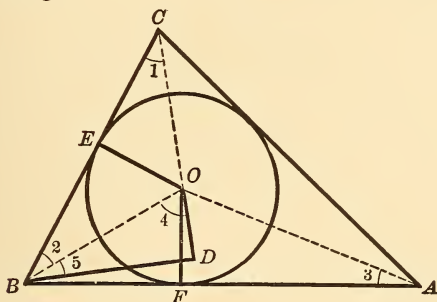

Fig. 21.

On CO produced drop the \perp BD from B . Let $OF = x$.

Now $\triangle BOD$ and $\triangle AOF$ are similar.

$$\text{Reason } \left\{ \begin{array}{l} \angle 1 + \angle 2 + \angle 3 = 90^\circ, \\ \text{but } \angle 1 + \angle 2 = \angle 4. \\ \therefore \angle 3 + \angle 4 = 90^\circ, \\ \text{but } \angle 4 + \angle 5 = 90^\circ. \\ \therefore \angle 3 = \angle 5. \end{array} \right.$$

$$\therefore a : x :: b : OD, \text{ whence } OD = \frac{bx}{a},$$

$$\therefore BD^2 = b^2 - \frac{b^2 x^2}{a^2},$$

$$\text{and } \overline{BC}^2 = \left\{ \overline{BO}^2 + \overline{CO}^2 + 2 \cdot CO \cdot OD \right\} = b^2 + c^2 + \frac{2bcx}{a}$$

* The teacher should endeavor to dispel the erroneous impression, prevalent among beginners, that Analytics is a mere application of algebra to Geometry.

Again, by similar $\triangle \overline{BC}^2 : \overline{BD}^2 :: \overline{OC}^2 : \overline{OE}^2$,

i. e.
$$\frac{ab^2 + ac^2 + 2bcx}{a} : \frac{a^2 b^2 - b^2 x^2}{a^2} :: c^2 : x^2,$$

whence $ax^2 \{ ab^2 + ac^2 + 2bcx \} = b^2 c^2 \{ a^2 - x^2 \}$:

or
$$x^3 + x^2 \left\{ \frac{ab}{2c} + \frac{ac}{2b} + \frac{bc}{2a} \right\} = \frac{abc}{2},$$

whence $x = OF$, the radius, can be found.

2. Given the perimeter p of a right \triangle and the altitude a on the hypotenuse. Required the sides.

Let the sides be $AB = x$, $BC = y$, $AC = z$.

Then $x^2 + y^2 = z^2 \dots\dots\dots (1)$

$x + y + z = p \dots\dots\dots (2)$

From similar $\triangle ABC$ and ABD ,

$z : y :: x : a,$

or $xy = az \dots\dots\dots (3)$

By solution of (1), (2) and (3)

$$z = \frac{b^2}{2(a+b)}.$$

$$2x = b - c + \sqrt{(b-c)^2 - 4ac}.$$

$$2y = b - c - \sqrt{(b-c)^2 - 4ac}.$$

3. Given the perimeter p of a right \triangle , and the 3 \perp s dropped on the sides from any internal point O . Required the sides.

Let $OE = a$, $OF = b$, $OG = c$,

Also $AB = x$, $BC = y$, $AC = z$.

Then $x + y + z = p \dots\dots\dots (1)$

$x^2 + y^2 = z^2 \dots\dots\dots (2)$

$$\frac{ax}{2} + \frac{by}{2} + \frac{cz}{2} = \frac{xy}{2},$$

or $ax + by + cz = xy \dots\dots\dots (3)$

from (1), (2) and (3) the sides may be found.

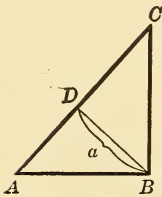

Fig. 22.

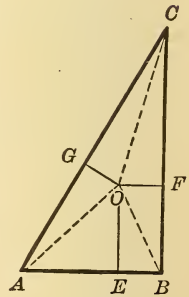

Fig. 23.

4. Through a point P within a \odot to draw a chord so that the parts PR and PQ may have a given difference d .

Let $PR = x$, then $PQ = x + d$.

Draw the diameter AB through P .

Let $PA = a$, $PB = b$, which are known.

Then $PQ \cdot PR = PA \cdot PB$,

or $(x + d)x = ab$,

whence $x = \sqrt{ab + \left(\frac{d}{2}\right)^2} - \frac{d}{2}$.

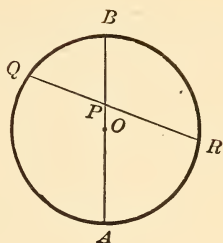

Fig. 24.

5. Given the perimeter of a right \triangle , P , and the radius, a , of its inscribed \odot . Required the sides.

Let $AB = x$,
 $BC = y$,
 $AC = z$.

Then $x + y + z = P$. . . (1)

$x^2 + y^2 = z^2$. . . (2)

$\frac{ax}{2} + \frac{ay}{2} + \frac{az}{2} = \left(\frac{aP}{2}\right) = \frac{xy}{2}$ (3)

Whence

$$x = \frac{2a + b \pm \sqrt{4a^2 - 12ab + b^2}}{4}$$

y and z are similarly found.

NOTE. — We might also use the relation $2a = x + y - z$.

6. Prove: of all rectangles of a given area, the square has the least perimeter.

Let a , and b , be the sides of any one of the rectangles.

Let x be the side of the equivalent square. Then $x = \sqrt{ab}$.

Hence we must prove $2x < a + b$, or $2\sqrt{ab} < a + b$.

Now $(a - b)^2 > 0$, $\therefore a^2 + b^2 > 2ab$,

$\therefore a^2 + b^2 + 2ab > 4ab$,

$\therefore a + b > 2\sqrt{ab}$,

or $2\sqrt{ab} < a + b$.

Q.E.D.

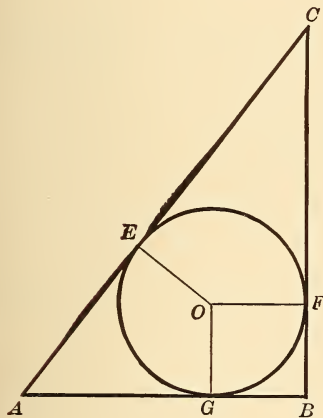

Fig. 25.

7. To divide a given angle ABC into two parts so that their sines may have a given ratio.* Take $BD : BE$ in the given ratio. Draw BF

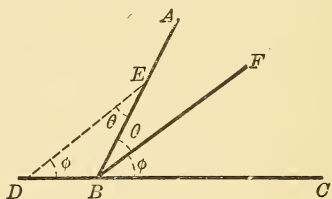

Fig. 26.

parallel to DE . θ and ϕ are the angles required. By Trigonometry, $\sin \theta : \sin \phi :: BD : BE$.

8. So that their tangents may have a given ratio. Take any two lines AD, DB in the given ratio. On AB describe a segment to contain an

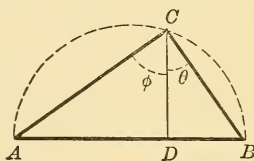

Fig. 27.

angle equal to the given angle. Draw $DC \perp AB$. θ and ϕ are the required angles.

9. So that the secants may have a given ratio.

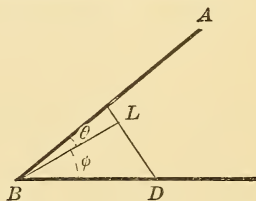

Fig. 28.

Take $BE : BD$ in given ratio.

Draw $BL \perp DE$.

θ and ϕ are the required angles.

* The following exercises 7–11 will be found useful sometimes in doing more difficult ones.

10. To construct a line equal to the square root of a given line.

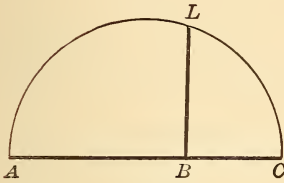

Fig. 29.

AB is the given line, whose length is given according to some definite unit.

Lay off BC, on AB prolonged, equal to one unit.

On AC as a diameter, describe a semicircle.

Draw $BL \perp AC$. BL is the line required.

$$\text{For } \overline{BL}^2 = AB \times BC = AB \times 1,$$

$$\therefore BL = \sqrt{AB}.$$

11. To construct two angles, having given the ratio of their sines and the ratio of their tangents.

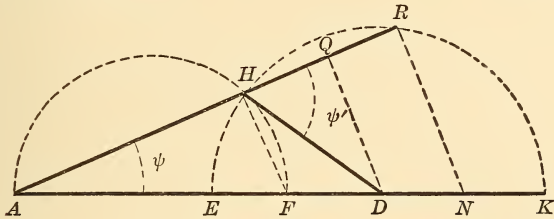

Fig. 30.

Take $AD : FD$ in given ratio of the tangents.

And $AD : ED$ in given ratio of the sines.

On AF as diameter describe a semicircle, and with D as center, DE as radius, describe another.

Through their point of intersection H, draw AHR.

$\angle DAR = \psi$, and $\angle DHR = \psi'$ are the required angles.

Draw $DQ \perp HR$, and $RN \parallel DQ$.

$$\text{Now } \frac{\sin \psi}{\sin \psi'} = \frac{\overline{DQ}}{\overline{DA}} = \frac{DA}{\overline{DH}} = \frac{DA}{\overline{DE}} = \text{given ratio.}$$

$$\text{and } \frac{\tan \psi}{\tan \psi'} = \frac{\overline{AQ}}{\overline{DQ}} = \frac{AQ}{\overline{HQ}} = \frac{AD}{\overline{FD}} = \text{given ratio.}$$

Q.E.F.

EXERCISES.

1. Bisect a given Δ by a line \perp to the base.
2. Find the side of the square inscribed in a given Δ if the base and altitude of the latter are given.
3. Given the area of a rectangle inscribed in a given Δ , to find the sides of the rectangle.
4. To bisect a given trapezoid by a line parallel to its bases.
5. Given the base, sum of the two sides, and the median to the base of a Δ , to find the sides.
6. Bisect a given Δ by the shortest line possible.
7. Trisect a given Δ by lines parallel to the base.
8. In a Δ , given two sides and the bisector of their included angle. Find the base.
9. In a right Δ , given the hypotenuse and the side of the inscribed square. Find the legs of the Δ .
10. Divide a given line into two parts so that the square on one may be equal to twice the square on the other.
11. Find the area of an equilateral Δ in terms of its side.
12. Find the sides of a Δ if the base, the altitude, and the ratio of the sides are given.
13. Also, when the ratio of the sides and the segments of the base made by the altitude are given.
14. Find the sides of a Δ , having given the base, altitude, and sum or difference of the sides.
15. Determine a Δ , having given its three medians. Divide a given angle into two parts so that :
 16. Its cosines may have a given ratio.
 17. Its cotangents may have a given ratio.
 18. Its cosecants may have a given ratio.
19. Find the radius of the inscribed circle of a Δ in terms of the sides.
20. Divide a given acute angle into two parts so that the rectangle of their sines may be a given quantity.
21. Also, so that the rectangle of their tangents be given.
22. Determine a right Δ , having given the radius of the inscribed circle and the side of the inscribed square.

23. From a given Δ cut off an isosceles Δ equal to one-third of the given Δ .

24. An equilateral Δ is inscribed in a given square, having one vertex at one corner of the square. Find the side of the Δ in terms of that of the square.

25. Determine a Δ having given the base, altitude, and product of the sides.

26. Three equal circles are inscribed in a given circle tangent to each other and to the given circle. Find their radii.

27. Transform a given Δ into an equilateral Δ .

28. In a right Δ , given the hypotenuse and the difference between the two lines drawn from its extremities to the in-center. Find the legs.

29. Also, if the two medians to the legs are given.

30. Given the points $(3, -1)$, $(6, 4)$. Find the point of trisection nearest the first. Also find the co-ordinates of a point in the line [produced] such that its distance from the second equals the distance between the first two points.

31. Find the distance between the points $(0, -2)$, $(1, -3)$.

32. Given the points $(1, 2)$ and $(7, -13)$. Find the point of trisection nearest the first.

33. Show that these points form a square, viz., $(1, 9)$, $(5, 6)$, $(-2, 5)$, and $(2, 2)$.

34. Show that the points $(-4, 1)$, $(2, 3)$, $(-1, 2)$ are collinear.

35. Find the area of the Δ $(0, 0)$, $(4, -5)$, and $(2, 3)$.

36. Show that these four points form a parallelogram, viz., $(5, 2)$, $(-1, -2)$, $(2, 1)$, and $(2, -1)$.

37. Transform to rectangular co-ordinates the equation

$$\rho^2 = \frac{2a^2}{\sin 2\theta}.$$

38. Find the distance between the points $\left(4, \frac{\pi}{3}\right)$, $\left(2\sqrt{2}, \frac{\pi}{4}\right)$.

39. Express in polar co-ordinates the equation $y^2 = 8x$.

40. Also the equation $x^2 - y^2 = k^2$.

41. Find the area and sides of the Δ whose vertices are $(a, a - b)$, $(b, b - c)$, $(c, c - a)$.

42. Show that the points $(0, 0)$, $(4, 70^\circ)$, $(4, 10^\circ)$ are the vertices of an equilateral Δ .

CHAPTER II

THE LOCUS OF AN EQUATION

14. A single equation in two variables x, y , is in general indeterminate and admits of an indefinite number of solutions, *i. e.*, we can find an indefinite number of pairs of values for x and y which will satisfy it. We shall observe, that if we think of each couple of values as representing the co-ordinates of a point in a plane, we can obtain from the equation a series of points all lying on a definite curve. This curve is called the **locus** or **graph** of the equation. To obtain an idea of the general shape and course of the curve, we have to determine several points in it (more or less according to the nature of its equation), and to draw a continuous "line" through them. To this end we solve the equation with respect to one of the variables and assign values to the other arbitrarily, but not differing widely from one another. We then find the corresponding values of the first variable. The points thus obtained are plotted and joined consecutively. The process will be better understood from a few examples.

Ex. 1. Construct the locus of the equation $y = 5x$.

The following table of values is readily computed.

x	1	2	3	4	0	$\frac{1}{2}$	$\frac{3}{2}$	- 1	- 2				
y	5	10	15	20	0	$\frac{5}{2}$	$1\frac{5}{2}$	- 5	- 10				etc.*

* Later on, the student is recommended to begin evaluating with $x = 0$, etc.

Plotting these points, we observe that they are ranged on a straight line which passes through the origin.

NOTE. — When an equation has no constant term, its locus passes through the origin.

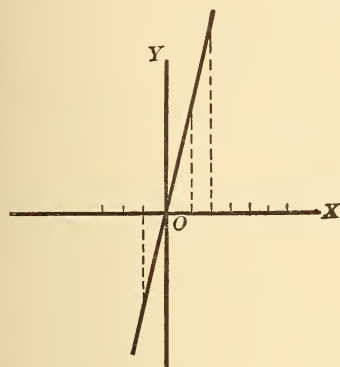

Fig. 31.

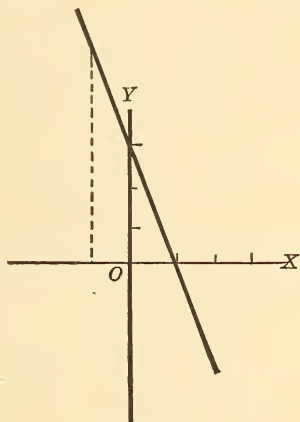

Fig. 32.

Ex. 2. Plot the locus of $6x + 2y - 3 = 0$;

here
$$y = \frac{3 - 6x}{2}.$$

The following table is readily found.

x	1	2	3	$\frac{1}{2}$	$\frac{3}{2}$	$\frac{5}{2}$	-1	-2	0			
y	$-\frac{3}{2}$	$-\frac{9}{2}$	$-\frac{15}{2}$	0	-3	-6	$\frac{9}{2}$	$\frac{15}{2}$	$\frac{3}{2}$			etc.

The locus is a straight line, not passing through the origin. In the figure each division is $\frac{1}{2}$, according to some chosen unit.

NOTE. — The beginner will notice as we go on, that the loci of equations of the first degree are invariably straight lines. This will be proved rigorously hereafter, but we may assume it to be true now as it will facilitate the construction of the graph. Since a straight line is determined by any two of its points, the graph of an equation of the first de-

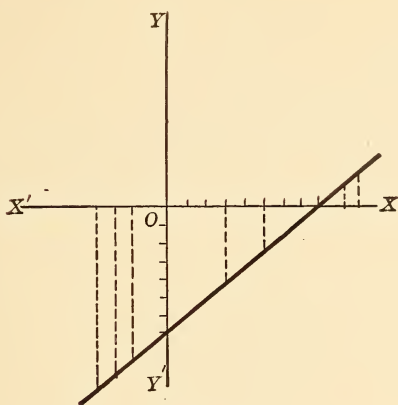

Fig. 35.

Ex. 5. $3x - 4y - 12 = 0$.

x	0	1	2	3	$\frac{1}{2}$	$\frac{3}{2}$	-1	-2	-3	4			etc.
	-3	$-\frac{9}{4}$	$-\frac{3}{2}$	$-\frac{3}{4}$	$-\frac{21}{8}$	$-\frac{15}{8}$	$-\frac{15}{4}$	$-\frac{18}{4}$	$-\frac{21}{4}$	0			

The graph is shown in the figure. Each division is $\frac{1}{2}$.

Ex. 6. Construct the locus of $y + x = 0$.

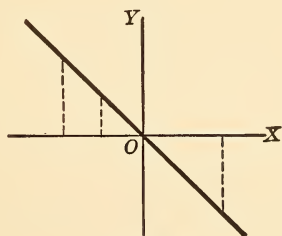

Fig. 36.

The student can easily compute the table of values. The line passes through the origin, and the second and fourth quadrants, cutting the x -axis at an angle of 45° .

Ex. 7. Construct the graph $x - y = 0$.

By the student.

Ex. 8. Construct the locus of $x = 3$.

This curve evidently has its abscissa always equal to 3. It is \therefore a line \perp to x -axis and at a distance 3 from the origin to the right.

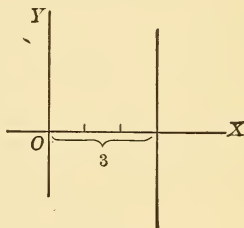

Fig. 37.

Ex. 9. Construct the locus of $x = -4$.

By the student.

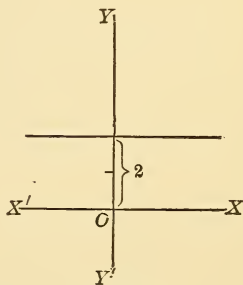

Fig. 38.

Ex. 10. $y - 2 = 0$.

This is evidently a line parallel to the x -axis and at a distance 2 above it.

Ex. 11. $y + 5 = 0$

By the student.

Ex. 12. Construct the locus of $9x^2 + 25y^2 = 900$.

$$y = \pm \frac{1}{5} \sqrt{900 - 9x^2}.$$

The following table is readily found.

x	y
± 1	± 5.96
± 2	± 5.87
± 3	± 5.72
± 4	± 5.49
± 5	± 5.19
± 6	± 4.80
± 7	± 4.28
± 8	± 3.60
± 9	± 2.61
± 10	± 0
0	± 6
etc.	etc.

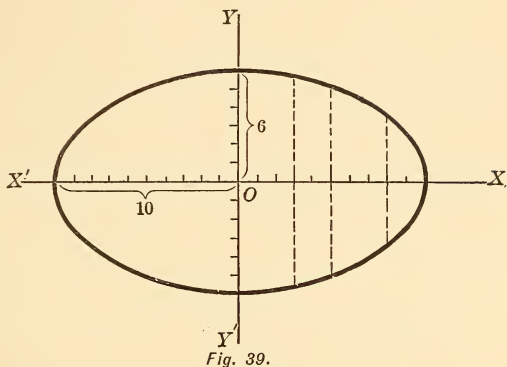

Plotting these points accurately and joining them by a smooth curve, they are found to lie on an **ellipse**.

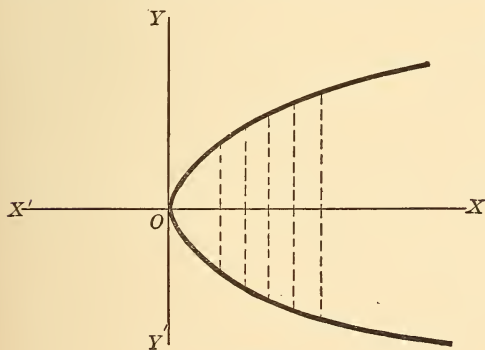

Ex. 13. Plot the curve $y^2 = 5x$,

$$y = \sqrt{5x}.$$

x	y
1	± 2.23
2	± 3.16
3	± 3.87
4	± 4.47
5	± 5.00
6	± 5.47
7	± 5.91
etc.	etc.

For negative values of x the value of y is imaginary; hence no point of the curve lies to the left of the y -axis. When $x = \infty, y = \infty$, hence the curve extends to the right without limit. It passes through the origin. The curve is called a **parabola**.

Ex. 14. Construct $x^2 + y^2 = 16$.

x	0	± 1	± 2	± 3	± 4					etc.
y	± 4	± 3.9	± 3.5	± 2.6	0					

The points are found to be arranged on the circumference of a circle whose center is at the origin and whose radius is equal to 4.

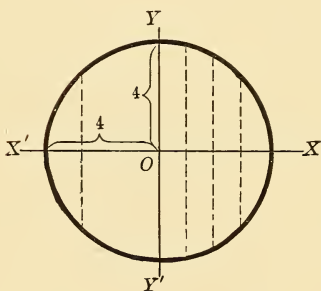

Fig. 41.

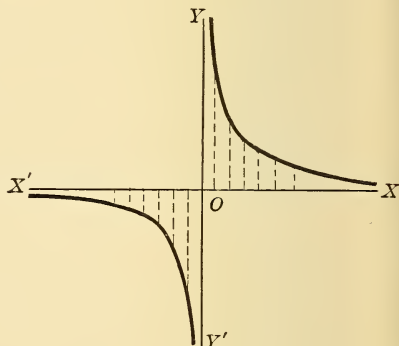

Fig. 42.

Ex. 15. Construct $xy = 4$.

$$y = \frac{4}{x}$$

x	0	± 1	± 2	± 3	± 4	∞				etc.
y	∞	± 4	± 2	$\pm \frac{4}{3}$	± 1	0				

Plotting these points, we get a curve consisting of two branches, one lying in the first quadrant, and the other in the third quadrant. The curve is known as the **hyperbola**.

Ex. 16. Construct

$$x^2 - 3x - 2y + 1 = 0$$

$$y = \frac{x^2 - 3x + 1}{2}$$

x	y
0	$\frac{1}{2}$
1	$-\frac{1}{2}$
2	$-\frac{1}{2}$
3	$\frac{1}{2}$
4	$\frac{5}{2}$
-1	$\frac{5}{2}$
-2	$\frac{11}{2}$

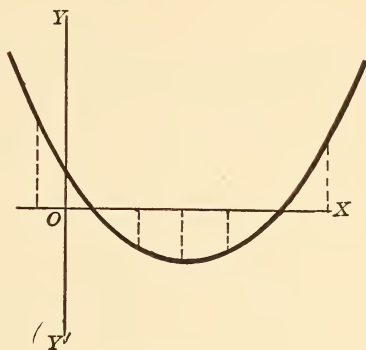

Fig. 43.

Plotting the points, we find the curve shown in the figure.

Ex. 17. Plot the curve $\frac{x^2}{4} - \frac{y^2}{9} = 1$.

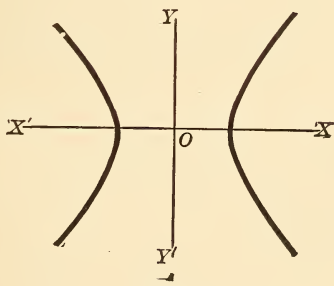

Fig. 44.

By the student.

The curve is an hyperbola and has the shape given in the figure.

EXERCISES.

Construct the following graphs or loci :

- | | |
|--|-----------------------------|
| 1. $y^2 = 4x$. | 11. $x^2 + y^2 = 9$. |
| 2. $x^2 = 9y$. | 12. $x^2 = 4y$. |
| 3. $3x^2 - 4y^2 = 12$. | 13. $x^2 + y^2 = 4$. |
| 4. $4x^2 + 3y^2 = 10$. | 14. $x^2 + x + y - 1 = 0$. |
| 5. $y = x^3 - 1$. | 15. $x^3 - 2x - y = 0$. |
| 6. $x = y^3 + 1$. | 16. $2x + y - 5 = 0$. |
| 7. $y^{\frac{1}{2}} = 2 - x^{\frac{1}{2}}$. | 17. $4xy - 1 = 0$. |
| 8. $x^3 = 4y$. | 18. $y = 2x^2 + 1$. |
| 9. $x - y = 3$. | 19. $x^2 - x - 1 = 0$. |
| 10. $2x - y = 1$. | 20. $x^2 = 6y$. |

15. Discussion of Equations. — The discussion of an equation is a critical examination made in order to ascertain the peculiarities of its locus, such as intercepts, limits of extent, symmetry, continuity, etc. The discussion of an equation of the first degree, which represents a straight line, consists generally in finding its intercepts and its direction with respect to the axes.

DISCUSSION OF EX. 12. — If $x = 0$, $y = \pm 6$; if $y = 0$, $x = \pm 10$.
These are the intercepts of the curve on the axes.

If $x > 10$, y is imaginary.

If $y > 6$, x is imaginary.

Hence $x = \pm 10$, $y = \pm 6$, are the greatest abscissas and ordinates respectively, of the curve. Again, for every value of x , there are two equal values of y , but unlike in sign; hence the curve is symmetrical with respect to the x -axis.

Similarly it is symmetrical with respect to the y -axes. It is therefore symmetrical with respect to the origin as a center.

DISCUSSION OF EX. 13. — If $x = 0$, $y = 0$; hence, curve passes through the origin.

Negative values of x give imaginary values of y ; hence no point of the curve lies to the left of the y -axis.

If $x = \infty$, $y = \infty$; the curve therefore extends to the right of the y axis without limit.

Again; for every value of x there are two equal and opposite values of y ; the curve is therefore symmetrical with regard to the x -axis.

Ex. 18. Trace the curve, $y = \sin x$.

x (in degrees).	y	x	y
0°	0.00	190°	— .17
10°	.17	200°	— .34
20°	.34	210°	— .50
30°	.50
40°	.64
50°	.77
60°	.87	270°	— 1.00
70°	.94		
80°	.98		
90°	1.00		
180°	0.00		

The curve has the form shown in the figure.

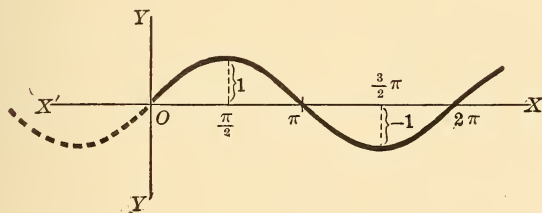

Fig. 45.

DISCUSSION.—The curve cuts the x -axis at intervals of 180° , since at these intervals $\sin x = 0$. It extends without limit on both sides of the origin, since an angle may have any magnitude positive or negative. The ordinate has its maximum values alternately $+1$ and -1 . The positive value corresponds to 90° , and the negative value to 270° . They recur at intervals of 360° . See Fig. 172, end of book.

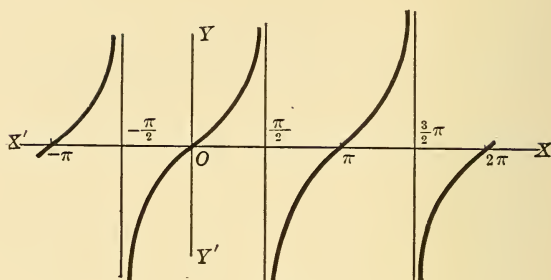

Fig. 46.

Ex. 19. Plot the curve $y = \tan x$.

x	y
0°	0.00
10°	.18
20°	.36
30°	.58
40°	.84
50°	1.19
60°	1.73
70°	2.75
80°	5.67
90°	∞
-10°	-.18
-20°	-.36
...	...
...	...
etc.	etc.

DISCUSSION. — The curve cuts the x -axis at intervals of π ; *i. e.*, at $\pm 2\pi, \pm 3\pi$, etc. It is discontinuous at intervals of π ; *i. e.*, at $\pm \frac{\pi}{2}, \pm \frac{3}{2}\pi, \pm \frac{5}{2}\pi$, etc. When x passes through the value $\frac{\pi}{2}$, y changes from $+\infty$ to $-\infty$; and as x passes from $\frac{\pi}{2}$ to $\frac{3}{2}\pi$, y passes from $-\infty$ through 0, to $+\infty$. As in the case of the sine curve, this curve has an infinite number of branches.

NOTE. — The trigonometric curves may be readily traced by using the line values of the functions, thus :

If $\psi = POA$ is any angle at the center O , of \odot with radius equal to unity, we have

$\sin \psi = PN.$	$\text{ctn } \psi = BM.$
$\cos \psi = ON.$	$\sec \psi = OD.$
$\tan \psi = AD.$	$\text{csc } \psi = OB.$

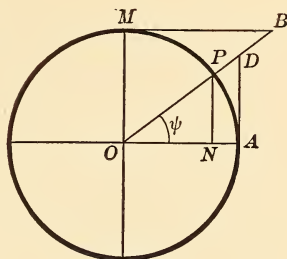

Fig. 47.

EXERCISES.

Trace these curves :

- | | |
|------------------------------|------------------------------------|
| 1. $y = 3 \sin x.$ | 6. $y = 3 \csc x.$ |
| 2. $2y = \text{ctn } x.$ | 7. $y = \sin x + \cos x.$ |
| 3. $y = \frac{1}{2} \cos x.$ | 8. $y = \tan x + 2 \text{ctn } x.$ |
| 4. $y = \text{ctn } x.$ | 9. $x = \sin y.$ |
| 5. $y = \sec x.$ | 10. $2x = \cos y + \sin y.$ |

16. **Definitions.** — The student is now prepared to give a definition of the locus of an equation; it is the “line” or group of lines such that the co-ordinates of every point on it satisfy the given equation.

Conversely. — The equation of a locus is the equation satisfied by the co-ordinates of every point on the locus. Or we might define a locus as the path of a point which moves under a given condition, *i. e.*, that imposed on it by a given equation.

NOTE 1. **DEFINITIONS.** — A **constant** is a quantity or symbol which does not change its value throughout the same discussion. A **variable** may have any value. An **absolute constant** is a numeral or a symbol representing a numeral; *e. g.*, $\pi = 3.1416$, $\sqrt{5}$, 16, etc.

An **arbitrary constant** is one which is constant in one investigation and is generally represented by the first letters of the alphabet, *a, b, c, h, k*. Variables are represented by the last letters of the alphabet, *e. g.*, x, y, z, w , etc.

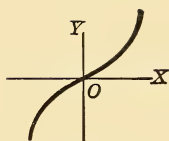

Fig. 48.

NOTE 2. DEFINITIONS. — The left-hand side of an equation is called the *sinister*, the right side the *dexter*.

EXERCISE. — Show that the locus of the equation $y = x^3$ has the form given here.

17. Product of Two or More Equations. — The locus of the product of two or more equations whose dexters are zero embraces the combined loci of the equations. Thus, the locus of

$$\begin{array}{l} \text{The product} \\ \text{of} \\ (1), (2), (3), \end{array} \left\{ \begin{array}{l} S_1 = 0 \\ S_2 = 0 \\ S_3 = 0 \end{array} \right\} \begin{array}{l} (1) \\ (2) \\ (3) \end{array}$$

is represented by $S_1 \cdot S_2 \cdot S_3 = 0$, for it evidently contains all points on these loci.

EXAMPLES: —

- | | |
|----------------------------------|--|
| (1) Find the locus of $xy = 0$. | <i>Ans.</i> The axes. |
| (2) $x^2 - y^2 = 0$. | <i>Ans.</i> The two lines $x = y, x = -y$. |
| (3) $4x^2 - 9y^2 = 0$. | <i>Ans.</i> The lines $2x - 3y = 0$
$2x + 3y = 0$. |
| (4) $x^2 - 6x + 8 = 0$. | <i>Ans.</i> The lines $x - 4 = 0$
$x - 2 = 0$. |
| (5) $x^2 + 8xy + 12y^2 = 0$. | <i>Ans.</i> The lines $x + 2y = 0$
$x + 6y = 0$. |
| (6) $y^3 - x^3 = 0$. | <i>Ans.</i> The curves $y - x = 0$,
and $y^2 + xy + x^2 = 0$. |

EXERCISES.

Trace the following curves :

- | | |
|----------------------------|--|
| 1. $3x - 4y = -12$. | 4. $\theta = 0$. |
| 2. $x^2 + y^2 = 49$. | 5. $\theta = 60^\circ, 30^\circ, 45^\circ, 120^\circ$, etc. |
| 3. $y^2 - x^2 + x^3 = 0$. | 6. $\rho = 4 \sin^2 \theta$. |

* NOTE. — It is obvious that the locus of an equation whose dexter is zero, can be more readily traced if the sinister is factorable.

7. $y^2 = 9x^2$.
 8. $x^2 = 16y^2$.
 9. $x^2 - xy + 1 = 0$.
 10. $y^2 = 4$.
 11. $x^2 = 9$.
 12. $x^2 - y^2 = 6$.
 13. $y = x + 2$.
 14. $y^2 = 16x$.
 15. $x + y - 9 = 0$.
 16. $3x - 5 = 0$.
17. $2x - 3y = 6$.
 18. $xy = 36$.
 19. $x^2 + y^2 = 1$.
 20. $\rho = 5, \theta = \frac{\pi}{3}$.
 21. $x^2 - 2y^2 = 0$.
 22. $x + 3y = 9$.
 23. $y - 5x = 4$.
 24. $3x - 2y = 6$.
 25. $\rho = 2a \cos \theta$.

Find the points of intersection of the following loci :

26. $y^2 = 4x, y = 6$.
 27. $x + y - 4 = 0, 3x + y = 6$.
 28. $\frac{x}{a} + \frac{y}{b} = 1, \frac{x}{b} + \frac{y}{a} = 1$.
 29. $x^2 + y^2 = 25, x = 2y$.
 30. $y^2 = 6x, 2x + 3y = 0$.
 31. $y = -x^3, x - y = 0$.
 32. $x + y = 4, y = 5$.
 33. $x^2 + y^2 = 9, y = 3x - 1$.
 34. $\rho = 2 \cos \theta, \rho \cos \theta = 4$.
 35. $\rho = 2a \cos \theta, \tan \theta = 3$.
 36. $y = \sin x, y = 3 \cos x$.
 { Ans. $\rho = \pm 2\sqrt{2}, \theta = \cos^{-1}\sqrt{2}$.

37. Find the intercepts of these loci :

- (1) $x^2 + y^2 - 4x - 8y - 5 = 0$.
 (2) $2(x - 2)^2 = y + 1$.
 (3) $y = x^3 - 3x^2 + 14$.
 (4) $x^2 + y^2 - 8x + 6y + 12 = 0$.
 (5) $\frac{x^2}{9} + \frac{y^2}{16} = 1$.

38. Find where the curves $\rho = 2 \sin \theta$, and $\rho^2 = 4 \cos^2 \theta$ cut the polar axis.

39. Find a point on the curve $y^2 = 9x$, whose abscissa is twice its ordinate.

40. Find the area of the Δ formed by the three lines, $x - y = 0$, $x + 2y = 0$, and $-3x + 2y = 5$.

41. Find the distance between the points of intersection of the curves $x^2 + y^2 = 49$, $2x + y = 0$. Also, $y^2 = 4x$, $x = y$.

42. For what values of k will the curves $x^2 + y^2 = 4$, and $2x + 3y - k = 0$ not intersect?

43. When will the curves $y^2 = 4x$, and $y = 2x + k$ meet in two coincident points?

44. Find the points of intersection of the loci,

$$\frac{x^2}{4} + \frac{y^2}{1} = 1, \quad \frac{x^2}{4} - \frac{y^2}{1} = 1.$$

45. Write the equation of the locus passing through the points of intersection of the curves $x^2 + y^2 = 25$, and $y = 3x + 4$.

46. Construct the locus of $\rho = 2\theta$.

47. Construct $\rho = b' \cos 2\theta$, and $\rho = b \sin 2\theta$.

48. Construct $2y^2 = 3x^3$, $y = 2x^3$, $x = y^3$.

49. Construct $x^3 - y^3 = 0$, $x - x^3 = -8$, $x^3 - x = 0$.

50. Construct $x^2 - 9y^2 = 0$, $4x^2 - 25y^2 = 0$.

51. Find the points of intersection of the curves,

$$\frac{x^2}{4} - \frac{y^2}{25} = 1, \quad \frac{x^2}{4} + \frac{y^2}{25} = 1.$$

52. Find a point on the curve $\frac{x^2}{25} - \frac{y^2}{16} = 1$ whose abscissa is 3 times its ordinate.

CHAPTER III

THE EQUATION OF A LOCUS

18. To reverse the process of the preceding chapter, *i.e.*, to find the equation of the path or locus of a given point, when we are given the conditions under which that point moves, is a more difficult and complicated task. We shall endeavor to introduce the student to the method by a series of easy examples.

Ex. 1. To find the equation of the locus of a point P, which moves so that the sum of its distances from two fixed points A and B is constant and equal to $2a$.

Take the line AB as x -axis and its \perp bisector as y -axis. Let $AB = 2c$. Also let P (x, y) be the position of the moving point at any moment. Then, by the condition, we have,

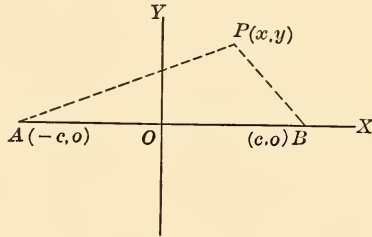

Fig. 49.

$$\sqrt{(x+c)^2 + y^2} + \sqrt{(x-c)^2 + y^2} = 2a \quad \dots \quad (1)$$

or
$$\sqrt{(x+c)^2 + y^2} = 2a - \sqrt{(x-c)^2 + y^2}.$$

Square both sides and simplify :

$$a \sqrt{(x-c)^2 + y^2} = a^2 - cx.$$

Squaring again,
$$a^2 (x-c)^2 + a^2 y^2 = (a^2 - cx)^2,$$

which gives,
$$(a^2 - c^2) x^2 + a^2 y^2 = a^2 (a^2 - c^2).$$

Put $a^2 - c^2 = b^2$, and divide the equation by its dexter, we get

$$\frac{x^2}{a^2} + \frac{y^2}{b^2} = 1.$$

This equation represents an ellipse, and is the required locus. The curve will be discussed in a subsequent chapter.

Ex. 2. If in Exercise 1 the difference of the distances is given equal to $2a$, find the locus of the point P.

The work is similar, giving for the required locus, the equation,

$$\frac{x^2}{a^2} - \frac{y^2}{b^2} = 1.$$

This represents an hyperbola which will be discussed later.

Ex. 3. A, B, and C are any three points not in the same straight line. Find the locus of a point P in their plane which moves so that

$$\overline{PB}^2 + \overline{PC}^2 = 2\overline{PA}^2.$$

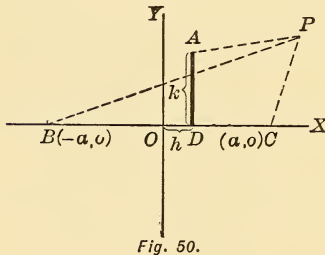

Fig. 50.

Let $BC = 2a$, and take BC as x -axis, and its \perp bisector as y -axis. Let A be the point (h, k) .

$$\text{Now } \overline{PB}^2 = (x + a)^2 + y^2;$$

$$\overline{PC}^2 = (x - a)^2 + y^2.$$

$$\overline{PA}^2 = (x - h)^2 + (y - k)^2.$$

\therefore By the condition,

$$(x + a)^2 + y^2 + (x - a)^2 + y^2 = 2[(x - h)^2 + (y - k)^2] \quad (1)$$

$$2x^2 + 2y^2 + 2a^2 = 2(x - h)^2 + 2(y - k)^2,$$

which reduces to,

$$2xh + 2yk = h^2 + k^2 - a^2,$$

which is the required locus, a straight line, since its equation is of the first degree. The result is the same if the point P is taken in any other quadrant than the first, the proper signs of its co-ordinates being observed.

NOTE.—Let the student work this exercise by taking any two \perp lines as axes, and calling A, B, and C, (x_1, y_1) , (x_2, y_2) , and (x_3, y_3) respectively. The result will also be of the first degree, but the beginner will see the advantage of a careful choice of axes.

Ex. 3. Find the equation of the locus in Ex. 2 when the three given points are collinear.

By the student.

Ex. 4. Given the base of a $\Delta = 2a$, and the difference between the squares of its sides $= k^2$. Required the locus of its vertex.

Take the base AB and its \perp bisector as axes. Let P (x, y) be one position of the vertex.

Then $\overline{PA}^2 = (x + a)^2 + y^2$;
 $\overline{PB}^2 = (x - a)^2 + y^2$.

\therefore By the condition,

$$\overline{AP}^2 - \overline{BP}^2 = k^2,$$

or, $(x + a)^2 + y^2 - [(x - a)^2 + y^2] = k^2,$

whence, $4ax = k^2.$

$\therefore x = \frac{k^2}{4a}$ is the equation of the required locus.

It is a straight line \perp to the x -axis.

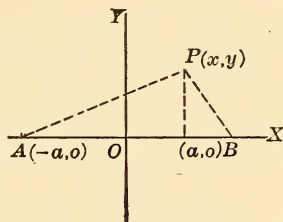

Fig. 51.

Ex. 5. A line parallel to the base of a Δ cuts off a trapezoid. Find the locus of the point of intersection of its diagonals.*

Let the sides AB, AC of the given ΔABC be the axes. Let DE be \parallel to BC. Also let $AB = a$, $AC = b$, and let AD and AE be respectively equal to ka , kb , since they are proportional to the sides a and b .

Then the equation of BE is

$$\frac{x}{a} + \frac{y}{kb} = 1 \quad \dots (1)$$

And the equation of CD is $\frac{x}{ka} + \frac{y}{b} = 1 \quad \dots \dots \dots (2)$

Subtract one equation from the other, and divide by $(1 - \frac{1}{k})$, obtaining as a result $\frac{x}{a} - \frac{y}{b} = 0, y = \frac{b}{a}x$ which is the required locus, a straight line, the median on BC.

* NOTE. — The beginner should defer reading this exercise until he has read the chapter on the straight line.

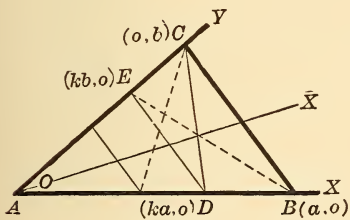

Fig. 52.

Ex. 6. In a $\triangle OCD$, we are given the base = c , and the sum of the two varying sides = m . The altitude CM is produced beyond the vertex to P , so that $MP = OC$ always. Find the locus of the point P .

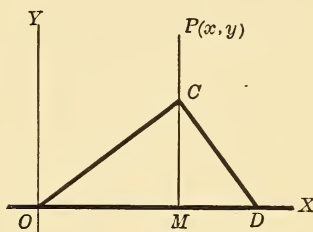

Fig. 53.

Take the base OD as x -axis, and a \perp to it at O as y -axis.

$$\text{Then } OC = MP = y,$$

$$CD = m - y.$$

Now,

$$\overline{MC}^2 = \overline{OC}^2 - \overline{OM}^2 = y^2 - x^2,$$

And

$$\overline{MC}^2 = \overline{CD}^2 - \overline{MD}^2 = (m - y)^2 - (c - x)^2.$$

$$\therefore y^2 - x^2 = (m - y)^2 - (c - x)^2 \quad (1).$$

Reducing, this gives $2cx - 2my + m^2 - c^2 = 0$,

which is the required locus, a straight line. Another solution :

Take the origin at the mid-point of the base. Let the \triangle be ABC .

$$\text{Then } AC = MP = y,$$

$$\text{And } BC = m - y.$$

Now,

$$\overline{BC}^2 = \overline{AC}^2 + \overline{AB}^2 - 2AB \times AM,$$

$$\text{or, } (m - y)^2 = y^2 + c^2 - 2c \left(\frac{c}{2} + x \right);$$

$$\text{whence, } m^2 - 2my = -2cx,$$

$$\text{or, } y = \frac{c}{m}x + \frac{m}{2},$$

which represents a straight line as before.

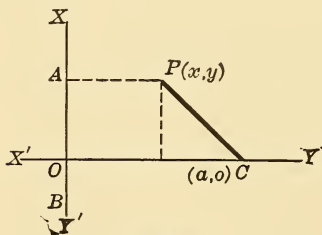

Fig. 55.

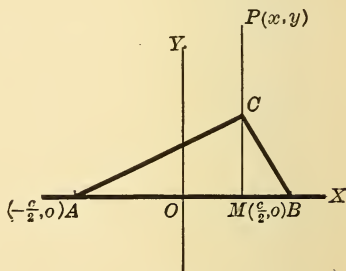

Fig. 54.

Ex. 7. Find the locus of point P , whose distance from a given line is proportional to the square of its distance from a given point.

Take the fixed line AB as y -axis, and let CO drawn \perp to AB from the given point C be the x -axis.

Put $OC = a$. Let $P(x, y)$ be any position of the moving point.

Then, by the conditions, $PA = k \overline{PC}^2$, where k is a constant,
 or, $x = k [(a - x)^2 + y^2]$,
 which represents the required locus.

Ex. 8. If in Ex. 4, the sum of the squares of the sides $= 2k^2$, find the locus of the vertex. *Ans.* $x^2 + y^2 = k^2 - a^2$.

Ex. 9. Given the base of a $\Delta = 2a$ and the product of the tangents of the base angles $= k$ (a constant), find the locus of the vertex P .

Take the origin at the mid-point of the base.

Then $\tan A = \frac{y}{a+x}$,

$\tan B = \frac{y}{a-x}$,

then, by the condition,

$$\frac{y}{a+x} \cdot \frac{y}{a-x} = k.$$

$$\therefore y^2 = k(a^2 - x^2)$$

is the required locus.

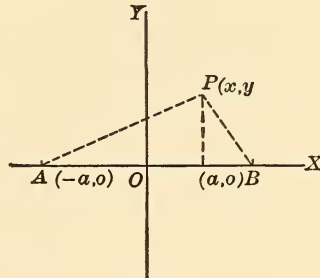

Fig. 56.

Ex. 10. Given the base of a $\Delta = 2a$, and the ratio of the squares of its sides, $m : n$; find the locus of the vertex. *Ans.* A circle.

Ex. 11. Given the base of an isosceles $\Delta = 2a$, find the locus of its vertex.

Ex. 12. Given the base of a $\Delta = 2a$, and the area $= c^2$, find the locus of its vertex. *Ans.* A line parallel to the base.

Ex. 13. Given the base and the ratio of the sines of the base angles, find the locus of the vertex. *Ans.* A circle.

NOTE. — Observe that these sines are to each other as the opposite sides.

Ex. 14. Find the locus of a point such that the sum of the squares of its distances from the four corners of a given square is constant, $= 8k^2$.

SUGGESTION. — Take the side of the square $= 2a$, and the required locus is a \odot with its center at the center of the square and a radius $= \sqrt{2}(k^2 - a^2)$.

Ex. 15. Find its locus if the sum of the squares of its distances from the sides of the square is constant. *Ans.* A circle.

Ex. 16. A and B are any two points. Find the locus of the point P such that $PA = k \cdot PB$. *Ans.* $(x + a)^2 + y^2 = k^2 \{ (x - a)^2 + y^2 \}$.

SUGGESTION. $\overline{PA}^2 = k^2 \cdot \overline{PB}^2$.

Ex. 17. A point moves so that the sum of its co-ordinates is always equal to 3. Find its locus. *Ans.* $x + y = 3$.

Ex. 18. A point moves so that the sum of the squares of its co-ordinates is equal to its abscissa plus 7. Find the locus of its vertex. *Ans.* $x^2 + y^2 = x + 7$.

Find the locus of a point which moves:

Ex. 19. So that the sum of the squares of its co-ordinates is always equal to twice their product. *Ans.* The line $x - y = 0$.

Ex. 20. So that the difference of its distance from two \perp lines is equal to 5 times its distance from their intersection.

SUGGESTION. — Take the fixed lines as axes.

Ex. 21. So that it is always equidistant from the points (2, 4) and (3, -5).

Ex. 22. So that its ordinate is $\frac{1}{4}$ of its abscissa plus 9.

Ex. 23. So that its ordinate equals its abscissa.

Ex. 24. So that its distance from (h, k) is 3 times its distance from (a, b) .

Ex. 25. So that it is always at a distance k from origin.

Ex. 26. So that it is always at a distance k from (a, b) .

Ex. 27. A, B, C, and D are four given points. Find the locus of P such that $\triangle PAB + \triangle PCD = k^2$ (a constant). *Ans.* A straight line.

Ex. 28. Also so that $\triangle PAB - \triangle PCD = k^2$.

Ex. 29. Polar co-ordinates.* A line revolves around a fixed point O, meeting a given line PM in a point P. Find the locus of the point Q in the revolving line so that $OP \cdot OQ = k^2$.

Take O as the pole, and $OM \perp$ to PM as polar axis. Let the point Q be (ρ, θ) , and let $OM = a$.

Then $a = OP \cos \theta$.

* When a line revolves about a fixed point, and the locus of a point on the moving line is desired, it is more convenient to use polar co-ordinates.

But, by the condition,

$$OP \cdot \rho = k^2, \text{ or } OP = \frac{k^2}{\rho} \dots \text{ [equation of the locus].}$$

or $\therefore a = \frac{k^2}{\rho} \cdot \cos \theta,$

$$a\rho = k^2 \cos \theta,$$

which represents the required locus.

NOTE. — To transform to rectangular co-ordinates, this result may be written :

$$a \rho^2 = k^2 \cdot \rho \cos \theta,$$

or $a(x^2 + y^2) = k^2x,$

which shows that the locus of the point Q is a circle.

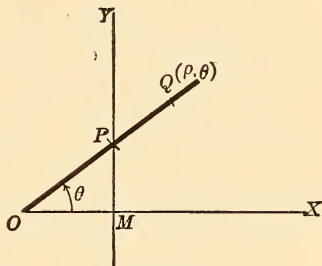

Fig. 57.

Ex. 30. Trace the locus of the equation $\rho = 2a \cos \theta$, by assigning values to θ and finding the corresponding values of ρ . Then transform to rectangular co-ordinates.

EXERCISES.

1. Given the base and the median drawn from one extremity [in a Δ], find the locus of the vertex.

SUGGESTION. — Let $b =$ base, $m =$ median. Let $(h, k,)$ be the other extremity of the median, where the base is the x -axis, and the extremity is the origin.

Ans. A circle, center $(-c, o)$, radius $2m$.

2. Find the locus of a point which moves so as to divide in a given ratio all the lines that can be drawn from a given point to a fixed line.

3. Find the locus of a middle point of a line of constant length, a , which moves so that its ends always touch two fixed \perp lines.

SUGGESTION. — Take the fixed lines for axes. *Ans.* $4(x^2 + y^2) = a^2$.

4. A square is so moved that one of its diagonals always has its extremities in two fixed \perp lines. Show that the second diagonal has its extremities [always] in two other fixed \perp lines.

5. One side AB of a Δ is given in length, and another side AC of constant length revolves about the fixed point A. Find the locus of the mid-point of the third side.

SUGGESTION. — Put $AB = a, AC = c$. Take AB as axis of x .

$$\text{Ans. } \left(x - \frac{a}{2}\right)^2 = \left(\frac{b}{2}\right)^2 - y^2.$$

6. A right \triangle is moved so that the extremities of the hypotenuse always touch two fixed \perp lines. Find the locus of the vertex of the right angle.

7. Two points P and Q are taken in the sides AB and AC of the \triangle ABC, such that $AP \cdot AQ = BP \cdot CQ$. Find the locus of the mid-point of PQ.

SUGGESTION. — Put $AB = a$, $AC = b$. Take AB and AC as axes. If (x, y) is the mid-point of PQ, we have $AP = 2x$, $AQ = 2y$.

Ans. $4xy = (a - 2x)(b - 2y)$, a straight line.

8. A and B are two fixed points. If PA and PB intercept a constant length, k , on a given line, find the locus of P.

SUGGESTION. — Let AB meet the given line in O. Take the given line and AB as axes, and O as the origin.

Let $OA = a$, $OB = b$.

Ans. $k(a - y)(b - y) = (a - b)xy$.

The base AB of a \triangle is given, where A is $(-a, 0)$, B $(a, 0)$.

Find the locus of the vertex C if,

9. $\cot A + m \cot B = k$. *Ans.* $(1 - m)x - ky + (1 + m)a = 0$.

10. $B = 2A$.

Ans. $3x^2 - y^2 + 2ax - a^2 = 0$.

11. $m \cdot \overline{AC}^2 + n \cdot \overline{BC}^2 = k^2$.

Ans. $(m + n)(x^2 + y^2) + 2(m - n)ax + (m + n)a^2 - k^2 = 0$.

12. $A - B = \phi$.

Ans. $x^2 - y^2 - 2xy \cot \phi - a^2 = 0$.

13. A straight line of variable length, OP, revolves about O, so that OP is equal to the product of a constant k , by the cosine of the angle which it makes with the initial line.

Find the locus of P.

Ans. $\rho = k \cos \theta$.

CHAPTER IV

THE STRAIGHT LINE

19. The equation of the straight line through two given points (x_1, y_1) (x_2, y_2) .

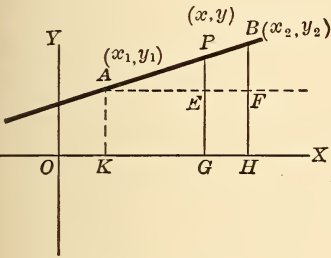

Fig. 58.

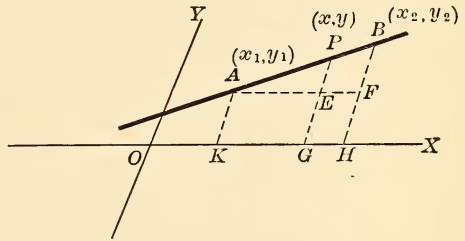

Fig. 59.

Let $P(x, y)$ be any point on the line. Draw the ordinates and \parallel s as indicated in the figures.

Then by similar Δ , $\frac{BF}{AF} = \frac{PE}{AE}$.

$$\therefore \frac{y_2 - y_1}{x_2 - x_1} = \frac{y - y_1}{x - x_1},$$

or, $\frac{y - y_1}{x - x_1} = \left(\frac{y_2 - y_1}{x_2 - x_1} \right) = \frac{y_1 - y_2}{x_1 - x_2} \dots \dots (1)$

which may be written, $\begin{vmatrix} x & y & 1 \\ x_1 & y_1 & 1 \\ x_2 & y_2 & 1 \end{vmatrix} = 0 \dots \dots (2)$

Both forms should be remembered.

20. Condition for three collinear points. The line through the points

$$(x_2, y_2), (x_3, y_3), \text{ is } \begin{vmatrix} x & y & 1 \\ x_2 & y_2 & 1 \\ x_3 & y_3 & 1 \end{vmatrix} = 0.$$

Now, if the point (x_1, y_1) lie on this line, we have

$$\begin{vmatrix} x_1 & y_1 & 1 \\ x_2 & y_2 & 1 \\ x_3 & y_3 & 1 \end{vmatrix} = 0,$$

which is the condition that the three points (x_1, y_1) , (x_2, y_2) , (x_3, y_3) may be collinear.

NOTE. — Observe that this result agrees with that of § 11, cor. 2.

21. Symmetrical form of the equation of a straight line ; or the equation in terms of its intercepts, a and b .

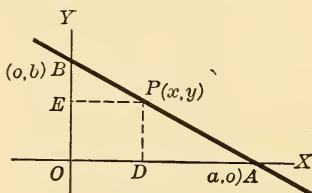

Fig. 60.

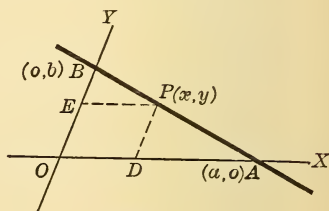

Fig. 61.

$$OA = a, \quad OB = b.$$

$P(x, y)$ is any point on the line.

Now, by similar \triangle , $\frac{OB}{OA} = \frac{DP}{DA}$.

$$\therefore \frac{b}{a} = \frac{y}{a-x},$$

whence,

$$\frac{x}{a} + \frac{y}{b} = 1 \quad \dots \dots \dots (1)$$

This equation may also be found thus: Since the line passes through the two points $(a, 0)$, $(0, b)$, its equation, by the preceding article, is

$$\begin{vmatrix} x & y & 1 \\ a & 0 & 1 \\ 0 & b & 1 \end{vmatrix} = 0;$$

whence,

$$\frac{x}{a} + \frac{y}{b} = 1, \text{ as before.}$$

QUERY.— What must be the signs of a and b , in order that this line may cut Quadrant I? II? III? IV?

22. Equation in terms of slope and intercept, where the slope is $\tan \theta$, the angle which the line makes with the x -axis.

Intercept $OB = b$. Let P be any point on the line.

Slope = $\tan \theta$ is generally represented by the symbol m .

Then, in the figure,

$$m = \frac{PE}{BE} = \frac{y - b}{x}.$$

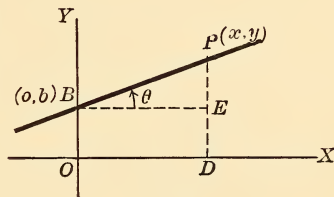

Fig. 62.

$\therefore y = mx + b$, the required equation.

QUERY.— What line is represented by the equation

$$x = ny + a?$$

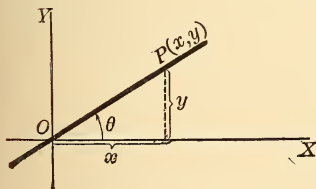

Fig. 63.

23. Equation of a line through the origin.

Let $P(x, y)$ be any point on the line.

Then, $m = \frac{y}{x},$

or, $y = mx. \dots (1)$

which is the form of the equation of a line passing through the origin.

EXAMPLE 1. — Find the equation of a line through the origin and the point (1, 2).

Let $y = mx$ be the required equation (m undetermined).

Then, since it passes through the point (1, 2), we have,

$$2 = m \cdot 1, \text{ or } m = 2.$$

$\therefore y = 2x$ is the required equation.

EXAMPLE 2. — Find equation of line through (0, 5) and making an angle of 60° with x -axis.

Here $b = 5, m = \tan 60^\circ = \sqrt{3}$.

$\therefore y = \sqrt{3}x + 5$ is the required line.

EXAMPLE 3. — Find the line through (-2, 3) and at 150° to x -axis.

Let $y = mx + b$ be the required equation.

$$m = \tan 150^\circ = -\frac{1}{\sqrt{3}};$$

and since line passes through point (-2, 3), we have

$$3 = \left(-\frac{1}{\sqrt{3}}\right)(-2) + b = \frac{2}{\sqrt{3}} + b.$$

$$\therefore b = 3 - \frac{2}{\sqrt{3}}.$$

$\therefore y = -\frac{1}{\sqrt{3}}x + 3 - \frac{2}{\sqrt{3}}$ is equation required.

EXAMPLE 4. — Find the equation of the line through the points (2, 3), (5, 7).

Let $y = mx + b$ be the required equation.

Then $3 = m \cdot 2 + b$ (1)

and $7 = m \cdot 5 + b$ (2)

From equations (1) and (2) m and b are readily obtained.

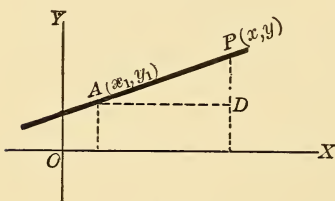

Fig. 64.

24. Equation in terms of one point (x_1, y_1) and slope m . —

P is any other point (x, y) on the line.

$$\text{Then } m = \frac{PD}{DA} = \frac{y - y_1}{x - x_1}.$$

$\therefore y - y_1 = m(x - x_1)$ is the required equation.

25. Normal Equation of the straight line. — This is the equation in terms of p (the \perp distance of the line from the origin) and a (the angle which this \perp makes with the x -axis).

$$\angle NOA = a, \quad OD = p.$$

$P(x, y)$ is any point on the line.

PM is \perp OA , PC is \perp MN , which is parallel to AB .

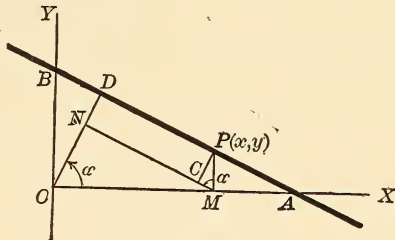

Fig. 65.

$$\angle CMP = a. \quad (\text{Why?})$$

$$OD = p = ON + CP = x \cos a + y \sin a,$$

$$\text{or,} \quad x \cos a + y \sin a = p \dots \dots \dots (1)$$

which is the required equation.

Another method :

$$\text{The equation to } AB \text{ is } \frac{x}{OA} + \frac{y}{OB} = 1.$$

$$\text{Now} \quad OD = OA \cos a \therefore OA = \frac{p}{\cos a}.$$

$$\begin{aligned} \text{Also} \quad OD &= OB \cos DOB \\ &= OB \sin a, \therefore OB = \frac{p}{\sin a}. \end{aligned}$$

$$\therefore \text{the equation becomes } \frac{x}{\left(\frac{p}{\cos a}\right)} + \frac{y}{\left(\frac{p}{\sin a}\right)} = 1,$$

or $x \cos a + y \sin a = p$, as before.

EXERCISES.

1. Find the slope form of the line through $(1, 2)$, $(5, -9)$.

SUGGESTION.—Let $y = mx + b$ be required equation.

$$\text{Then,} \quad \left. \begin{aligned} 2 &= m \cdot 1 + b \\ -9 &= m \cdot 5 + b \end{aligned} \right\} \text{ solve for } m \text{ and } b.$$

2. Find the symmetrical equation of the line through (4, -5) and (-3, 7).

SUGGESTION. — Let $\frac{x}{a} + \frac{y}{b} = 1$ be equation required.

Then,
$$\left. \begin{aligned} \frac{4}{a} - \frac{5}{b} &= 1 \\ -\frac{3}{a} + \frac{7}{b} &= 1 \end{aligned} \right\} \text{ solve for } a \text{ and } b.$$

3. Find the normal equation of the line through (2, -5) and (-3, 4).

SUGGESTION. — Let $x \cos \alpha + y \sin \alpha = p$ be equation required.

Then $2 \cos \alpha - 5 \sin \alpha = p$ (1)
and $-3 \cos \alpha + 4 \sin \alpha = p$ (2)
 $\cos^2 \alpha + \sin^2 \alpha = 1$ (3)

Solve (1), (2) and (3) for $\cos \alpha$, $\sin \alpha$, and p .

4. Find the equations of the lines joining :

(1). (1, 2) and (3, 4). (2). (-2, 3) and (3, -4). (3). (4, -6) and (-2, -5). (4). (a, b) and (b, a). (5). (a+b, c) and (c, a-b). (6). (3, 4) and (5, 2). (7). (-2, -5) and (6, -3). (8). (a+b, b+c) and (a-b, b-c). (9). (2, 4) and (3, 6). (10). (0, 0) and (a, b).

5. Construct the following lines, (1) $x = \pm 3$, $y = \pm 5$, $x \pm y = 0$. (2) $x + y = 1$, $3x - y + 4 = 0$, $2x + 3y + 1 = 0$.

6. What are the equations of the lines through the origin, and inclined respectively at 45° , 60° , and 120° to the x -axis ?

7. Find the equations of the lines, (1) through the point (1, 4) and at 45° to x -axis ; (2). through (-2, 3) and at 30° to x -axis ; (3). through (2, -5) and at 60° to x -axis ; (4). through (3, 4) and at 120° to x -axis ; (5). through (4, -6) and at 150° to x -axis.

8. Reduce the following equations, first to the slope form, then to the symmetrical form.

(1) $2x - 3y + 4 = 0$. (2) $x + 3y - 9 = 0$. (3) $y - x = 4$.
(4) $8x + 6y = 5$. (5) $x - 5y = 13$.

9. Find equations of these lines :

(1) through (1, 2) and parallel to $y = 3x + 4$;
(2) through (-5, -3) and parallel to $x - y = 0$;
(3) through (6, -4) and parallel to $2x - 5y = 16$.

SUGGESTION. — In (1) let $y = 3x + k$ be line required.

Then, $2 = 3 \cdot 1 + k$, $\therefore k = -1$.
 $\therefore y = 3x - 1$ is equation required.

10. Find the intercepts of :

- (1) $hx + ky = 1.$ (3) $8x - 2y = 4.$
 (2) $4x - 5y = 12.$ (4) $y - 3x = 2.$
 (5) $2ax + 5by = 13.$

11. Find the line through (4, 6) which cuts off equal intercepts on the axes.

12. Find the line through (3, 3) which forms with the axes a Δ whose area is 18.

SUGGESTION.— Let $\frac{x}{a} + \frac{y}{b} = 1$ be line required.

Then, $ab = 36.$ } . (1)
 $\frac{3}{a} + \frac{3}{b} = 1$ } . (2) Solve for a and b .

26. Any equation of the first degree in two variables, x, y , represents a straight line. — Take the most general form of such an equation, viz. :

$$Ax + By + C = 0.$$

Let $(x_1, y_1), (x_2, y_2), (x_3, y_3)$ be any three points on the locus represented by this equation, whatever it may be. Then,

$$Ax_1 + By_1 + C = 0 \quad (1)$$

$$Ax_2 + By_2 + C = 0 \quad (2)$$

$$Ax_3 + By_3 + C = 0 \quad (3)$$

We now propose to eliminate $A, B,$ and C from these three equations, and, if possible, to find some condition among the co-ordinates of the three points assumed, which may be interpreted in terms of known facts.

Subtract (2) from (1), then (3) from (2), obtaining

$$A(x_1 - x_2) + B(y_1 - y_2) = 0 \quad . . . (4)$$

$$A(x_2 - x_3) + B(y_2 - y_3) = 0 \quad . . . (5)$$

Eliminating B from (4) and (5), and dividing the resulting equation by A , we get

$$(x_1 - x_2)(y_2 - y_3) - (x_2 - x_3)(y_1 - y_2) = 0 \quad . (6)$$

or,
$$\begin{vmatrix} x_1 & y_1 & 1 \\ x_2 & y_2 & 1 \\ x_3 & y_3 & 1 \end{vmatrix} = 0,$$

which is the condition that the three points lie on a straight line. Hence, any three points on the locus of $Ax + By + C = 0$ are collinear; *i.e.*, the equation represents a straight line. *Q.E.D.*

27. The theorem of the preceding article may also be proved indirectly, and somewhat less rigorously, by showing that the equation $Ax + By + C = 0$ can be reduced to any one of the type forms which we have found in this chapter.

Thus, I.
$$By = -Ax - C^2.$$

$$y = -\frac{A}{B}x - \frac{C}{B}$$
 (which has the form $y = mx + b$).

II. If $B = 0$, then $Ax + C = 0$,

$$x = -\frac{C}{A} \quad (\text{form } x = a).$$

III. If $A = 0$, $y = -\frac{C}{B}$ (form $y = b$).

Or, IV.
$$\frac{Ax}{C} + \frac{By}{C} = -1,$$

Whence
$$\frac{x}{\left(-\frac{C}{A}\right)} + \frac{y}{\left(-\frac{C}{B}\right)} = 1 \quad \left\{ \begin{array}{l} \text{symmetrical form} \\ \frac{x}{a} + \frac{y}{b} = 1. \end{array} \right.$$

28. Reduction of $Ax + By + C = 0$ to the normal form. —

If $Ax + By + C = 0$ (1)
 and $x \cos a + y \sin a - p = 0$ (2)

represent the same line, they must differ by some constant

factor; *i.e.*, the coefficients in both equations must be proportional;

$$\therefore \frac{A}{\cos a} = \frac{B}{\sin a} = -\frac{C}{p}.$$

$$\therefore \frac{A^2}{\cos^2 a} = \frac{B^2}{\sin^2 a} = \left(\frac{A^2 + B^2}{\sin^2 a + \cos^2 a} \right) = \frac{C^2}{p^2}.$$

$$\therefore A^2 + B^2 = \frac{C^2}{p^2} \dots \dots \dots (1)$$

$$\frac{B^2}{\sin^2 a} = \frac{C^2}{p^2} \dots \dots \dots (2)$$

$$\frac{A^2}{\cos^2 a} = \frac{C^2}{p^2} \dots \dots \dots (3)$$

From (1), $p = \frac{C}{\sqrt{A^2 + B^2}}.$

From (2), $\sin a = \frac{Bp}{C} = \frac{B}{\sqrt{A^2 + B^2}}.$

From (3), $\cos a = \frac{A}{\sqrt{A^2 + B^2}}.$

Hence the normal form of $Ax + By + C = 0$ is

$$\frac{A}{\sqrt{A^2 + B^2}}x + \frac{B}{\sqrt{A^2 + B^2}}y = \frac{C}{\sqrt{A^2 + B^2}}.$$

Hence, to reduce the above equation to the normal form, divide through by the square root of the sum of the squares of the coefficients of x and y . It is convenient to change signs in $Ax + By + C = 0$ (if necessary) so that C may be negative; *i.e.*, the right member of the normal form may be positive.

NOTE 1. — Observe that the fractional coefficients of x and y above may be assumed to be the cosine and sine respectively of some angle, since the sum of their squares is equal to unity.

NOTE 2.—The generality of the proof of the normal form of the equation depends on the fact that whatever the magnitude of α , OA and $\cos \alpha$ have the same sign; and OB and $\sin \alpha$ have always the same sign. It is assumed generally that α is a positive angle.

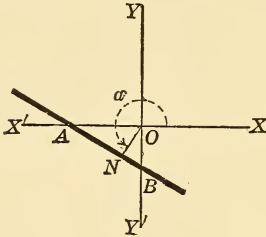

Fig. 66.

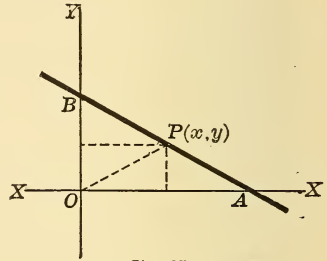

Fig. 67.

NOTE 3.—The symmetrical equation may be derived as follows :

$$2 \Delta AOB = 2 \Delta POB + 2 \Delta POA.$$

$$\therefore ab = bx + ay,$$

$$\frac{x}{a} + \frac{y}{b} = 1.$$

29. Reduction of $y = mx + b$, and $\frac{x}{a} + \frac{y}{b} = 1$, to the normal form.— These evidently become,

$$-\frac{m}{\sqrt{1+m^2}}x + \frac{1}{\sqrt{1+m^2}}y - \frac{b}{\sqrt{1+m^2}} = 0. \quad (1)$$

and

$$\frac{bx}{\sqrt{a^2+b^2}} + \frac{ay}{\sqrt{a^2+b^2}} - \frac{ab}{\sqrt{a^2+b^2}} = 0. \quad (2)$$

30. Digression on Algebra.— If we are given two equations, as

$$Ax + By + Cz = 0 \dots \dots \dots (1)$$

and

$$A_1x + B_1y + C_1z = 0 \dots \dots \dots (2)$$

it is proved in books on Algebra that

$$\frac{x}{\begin{vmatrix} B & C \\ B_1 & C_1 \end{vmatrix}} = \frac{y}{\begin{vmatrix} C & A \\ C_1 & A_1 \end{vmatrix}} = \frac{z}{\begin{vmatrix} A & B \\ A_1 & B_1 \end{vmatrix}};$$

or, more simply, if $z = 1$,

$$\begin{matrix} x \\ \left| \begin{array}{cc} B & C \\ B_1 & C_1 \end{array} \right| \end{matrix} = \begin{matrix} y \\ \left| \begin{array}{cc} C & A \\ C_1 & A_1 \end{array} \right| \end{matrix} = \begin{matrix} 1 \\ \left| \begin{array}{cc} A & B \\ A_1 & B_1 \end{array} \right| \end{matrix}.$$

Hence, this last equation determines the point of intersection of the lines

$$\left. \begin{aligned} Ax + By + C &= 0, \\ A_1x + B_1y + C_1 &= 0. \end{aligned} \right\}$$

We shall make use of this fact presently.

31. Condition for the concurrency of three given lines. —

Let the given lines be,

$$Ax + By + C = 0 \quad (1)$$

$$A_1x + B_1y + C_1 = 0 \quad (2)$$

$$A_2x + B_2y + C_2 = 0 \quad (3)$$

Solving for the point of intersection of (2) and (3), we get,

$$\begin{matrix} x \\ \left| \begin{array}{cc} B_1 & C_1 \\ B_2 & C_2 \end{array} \right| \end{matrix} = \begin{matrix} y \\ \left| \begin{array}{cc} C_1 & A_1 \\ C_2 & A_2 \end{array} \right| \end{matrix} = \begin{matrix} 1 \\ \left| \begin{array}{cc} A_1 & B_1 \\ A_2 & B_2 \end{array} \right| \end{matrix} = \lambda \text{ (say).}$$

$$\text{Then } x = \lambda \left| \begin{array}{cc} B_1 & C_1 \\ B_2 & C_2 \end{array} \right|, y = \lambda \left| \begin{array}{cc} C_1 & A_1 \\ C_2 & A_2 \end{array} \right|, 1 = \lambda \left| \begin{array}{cc} A_1 & B_1 \\ A_2 & B_2 \end{array} \right|.$$

If the three lines are to be concurrent, this point must lie on (1). Substitute these values in (1), and divide by λ ,

$$\therefore A \left| \begin{array}{cc} B_1 & C_1 \\ B_2 & C_2 \end{array} \right| + B \left| \begin{array}{cc} C_1 & A_1 \\ C_2 & A_2 \end{array} \right| + C \left| \begin{array}{cc} A_1 & B_1 \\ A_2 & B_2 \end{array} \right| = 0,$$

or,
$$\left| \begin{array}{ccc} A & B & C \\ A_1 & B_1 & C_1 \\ A_2 & B_2 & C_2 \end{array} \right| = 0,$$

which is the condition that the three lines given may be concurrent.

NOTE. — The line $y - y_1 = m(x - x_1)$ may represent any line of a pencil through the fixed point (x_1, y_1) .

EXAMPLE. — If it passes through the point $(-3, 4)$, we have

$$y - 4 = m(x + 3);$$

and if it makes 45° with x -axis, we have

$$y - 4 = 1(x + 3),$$

or,

$$y - x - 7 = 0.$$

32. Angle between Two Lines, $y = mx + b$, and $y = m'x + b'$.

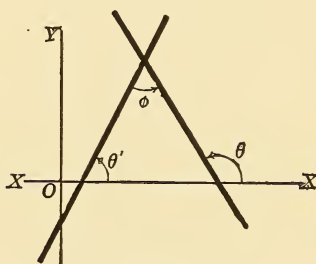

Fig. 68.

$$\phi = \theta - \theta'.$$

$$\therefore \tan \phi = \frac{m - m'}{1 + mm'}.$$

If the lines be \parallel , $\phi = 0$,

$$\therefore m - m' = 0, \quad m = m'.$$

If the lines be \perp , $\tan \phi = \infty$,

$$\therefore 1 + mm' = 0.$$

If the lines are given in the form

$$Ax + By + C = 0,$$

and

$$A'x + B'y + C' = 0,$$

they are parallel if

$$\frac{A}{B} = \frac{A'}{B'}$$

or,

$$\begin{vmatrix} A & B \\ A' & B' \end{vmatrix} = 0.$$

They are \perp if $1 + mm' = 0$, or $1 + \frac{AA'}{BB'} = 0$,

or

$$AA' + BB' = 0.$$

33. To Find the Equation of the Line through the Point (x_1, y_1) and \perp to the Line $Ax + By + C = 0$.

Let $y - y_1 = m'(x - x_1)$ be the required equation.

Then
$$m = -\frac{A}{B}, \therefore m' = \left(-\frac{1}{m}\right) = \frac{B}{A}.$$

$$\therefore y - y_1 = \frac{B}{A}(x - x_1),$$

or,

$$\frac{x - x_1}{A} = \frac{y - y_1}{B},$$

is the required equation.

EXERCISES.

1. Reduce the following equations to the normal form :

(1) $x + y = 3.$

(2) $5x - 12y + 20 = 0.$

2. Show that the lines, $\frac{x}{a} + \frac{y}{b} = 1$, $\frac{x}{b} + \frac{y}{a} = 1$, and $x = y$ are concurrent.

3. Find the area of the Δ whose sides are

$$x = y, \quad x = -3y, \quad x + y = -4. \quad \text{Ans. } 8.$$

4. Find the equation of the line joining (a, b) , and $(-a, -b)$.

5. Find the equations of the medians of the Δ whose vertices are $(2, 1)$, $(3, -2)$, $(-4, -1)$.

6. Show that the three points $(1, -1)$, $(2, 1)$, and $(-3, -9)$ are collinear.

7. Find the equation of the line through $(3, 4)$ and at 75° to the x -axis.
Ans. $y - 4 = (2 + \sqrt{3})(x - 3).$

8. Reduce the following equations to the symmetrical form :

(1) $3x + 2y + 6 = 0.$

(3) $y - 4x = 6.$

(2) $3x - 2y + 12 = 0.$

(4) $-y - x = 2.$

(5) $6x + 5y = 13.$

9. Reduce to the normal form :

(1) $3x + 4y = 12.$

(3) $4x - y = 0.$

(2) $x - 2y = 3.$

(4) $x - 2y = 1.$

(5) $x + y = 2.$

10. A straight line passes through the point $(3, 4)$ and is bisected at that point. Find its equation.

11. What system of lines are represented by the equation $x \cos \alpha + y \sin \alpha = 9$ if α be varied ?

12. By the equation $y = mx + 2$, if m be varied ?

13. Reduce to the normal form :

$$\frac{x}{a} + \frac{y}{b} = 1, \quad y = mx + c.$$

14. Show that the lines $2y - 3x = 7$, and $3y + 2x = 11$, are \perp to each other.

15. Find the angles between the following pairs of lines.

(1) $3x - 4y = 2$, $2x - y = 0$. Ans. $\tan \phi = -\frac{1}{2}$.

(2) $\frac{x}{a} + \frac{y}{b} = 1$, $\frac{x}{a} - \frac{y}{b} = 1$. Ans. $\tan \phi = \frac{2ab}{b^2 - a^2}$.

(3) $x - 2y = 0$, $2x + 3y = 1$.

16. Find the line through the point $(-1, -1)$ and \perp to the line $y - 2x = 1$.

17. Find the foot of the \perp from origin to $3x - 5y = 4$.

18. Find the line from $(2, 3)$ and \perp to $x - y = 0$.

19. Find the line through $(4, -6)$ and parallel to $x = 2y$.

34. To Find the Distance from the Point (x_1, y_1) to the Line $x \cos a + y \sin a = p$.

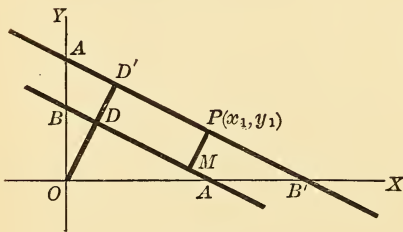

Fig. 69.

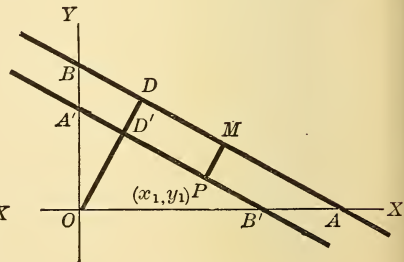

Fig. 70.

AB is the given line, $P(x_1, y_1)$ the given point, and $A'B'$ a line through P parallel to AB .

The equation to $A'B'$ is evidently $x_1 \cos a + y_1 \sin a = p_1$.

In Fig. (1),

$$PM = DD' = p_1 - p = x_1 \cos a + y_1 \sin a - p.$$

In Fig. (2),

$$PM = D'D = p - p_1 = p - x_1 \cos a + y_1 \sin a.$$

Hence, the distance from the point $P(x_1, y_1)$ to the line

$$x \cos a + y \sin a = p$$

is equal to $\pm [x_1 \cos a + y_1 \sin a - p]$,

the upper or lower sign being used according as the point and the origin are on opposite sides of the line or on the same side. Notice that the required expression is found by writing the equation of the line so that its dexter is zero, and then substituting the co-ordinates of the given point for x and y .

Again, if the equation be given in the form

$$Ax + By + C = 0,$$

the distance is evidently

$$d = \frac{Ax_1 + By_1 + C}{\sqrt{A^2 + B^2}}.$$

35. Equations of Bisectors of the Angles between the Lines,

$$Ax + By + C = 0 \quad \dots \dots \dots (1)$$

$$A_1x + B_1y + C_1 = 0 \quad \dots \dots \dots (2)$$

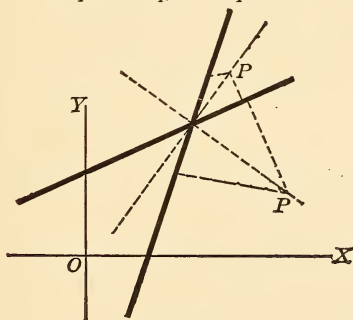

Fig. 71.

If $P(x_1, y_1)$ be any point on either bisector, it is equidistant from the sides of the angle,

$$\therefore \frac{Ax_1 + By_1 + C}{\sqrt{A^2 + B^2}} = \pm \frac{A_1x_1 + B_1y_1 + C_1}{\sqrt{A_1^2 + B_1^2}},$$

in which the upper sign is used for the bisector of the angle in which the origin lies.

If the lines are given in the form

$$x \cos a + y \sin a = p \quad . \quad . \quad . \quad (1)$$

$$x \cos a_1 + y \sin a_1 = p_1 \quad . \quad . \quad . \quad (2)$$

the bisectors are

$$x_1 \cos a + y_1 \sin a - p = \pm (x_1 \cos a_1 + y_1 \sin a_1 - p_1).$$

NOTE. — The subscripts to the letters x, y , may be dropped in the end.

36. Equation of a Line Through a Given Point (x_1, y_1) and Making a Given Angle ϕ with the Line $y = mx + b$. — There are obviously two lines fulfilling the conditions. AB is the given line.

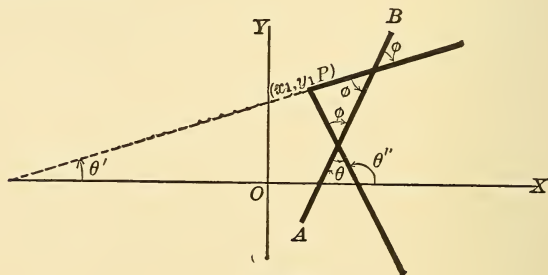

Fig. 72.

Let the required equation be

$$y - y_1 = m' (x - x_1).$$

Then,

$$\phi = \theta - \theta', \text{ or } \theta'' - \theta,$$

$$\therefore \tan \phi = \frac{m' - m}{1 + mm'}, \text{ or } \frac{m - m'}{1 + mm'},$$

$$\therefore m' = \frac{m \pm \tan \phi}{1 \mp m \tan \phi}.$$

∴ The required equation is

$$y - y_1 = \frac{m \pm \tan \phi}{1 \mp m \tan \phi} (x - x_1).$$

37. Oblique Axes. Equation of straight line in terms of intercept b , and angle θ , which the line makes with the x -axis.

$$\frac{PD}{BD} = \frac{\sin \theta}{\sin (\omega - \theta)},$$

or,

$$\frac{y - b}{x} = \frac{\sin \theta}{\sin (\omega - \theta)}.$$

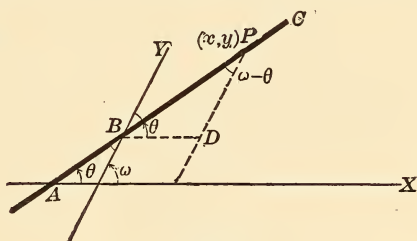

Fig. 73.

If we put $\frac{\sin \theta}{\sin (\omega - \theta)} = m$, we have $y = mx + b$.

When $\omega = 90^\circ$, $m = \tan \theta$.

38. Equation of line in terms of one point (x_1, y_1) and θ .

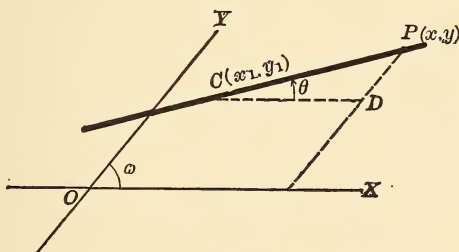

Fig. 74.

Let $P(x, y)$ be any point on the line.

Then,
$$\frac{PD}{CD} = \frac{\sin \theta}{\sin (\omega - \theta)},$$

or,
$$\frac{y - y_1}{x - x_1} = \frac{\sin \theta}{\sin (\omega - \theta)}.$$

39. Equation of a line in terms of the \perp on it from the origin and the angles which this \perp makes with the axes.

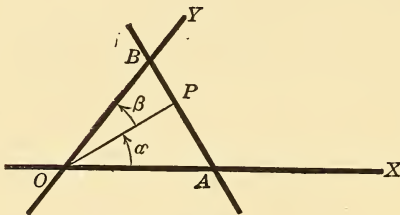

Fig. 75.

The equation of AB is

$$\frac{x}{OA} + \frac{y}{OB} = 1.$$

But $OA = \frac{p}{\cos \alpha},$

$$OB = \frac{p}{\cos \beta},$$

where $p = OP.$

$$\therefore x \cos \alpha + y \cos \beta = p$$

is the required equation.

40. Polar Co-ordinates. Equation of the straight line through two points (ρ_1, θ_1) and (ρ_2, θ_2) .

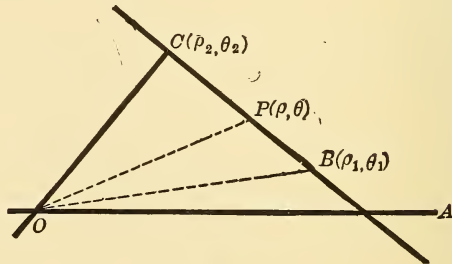

Fig. 76.

$$\triangle OBC = \triangle OBP + \triangle OCP.$$

$$\therefore \frac{1}{2} \rho_1 \rho_2 \sin (\theta_2 - \theta_1) = \frac{1}{2} \rho \rho_1 \sin (\theta - \theta_1) + \frac{1}{2} \rho \rho_2 \sin (\theta_2 - \theta).$$

$$\therefore \rho \rho_1 \sin (\theta - \theta_1) + \rho_1 \rho_2 \sin (\theta_1 - \theta_2) + \rho_2 \rho \sin (\theta_2 - \theta) = 0,$$

or,
$$\frac{\sin (\theta_1 - \theta_2)}{\rho} + \frac{\sin (\theta_2 - \theta)}{\rho_1} + \frac{\sin (\theta - \theta_1)}{\rho_2} = 0.$$

This result can be easily remembered in the determinant form, viz.:

$$\begin{vmatrix} \frac{1}{\rho} & \cos \theta & \sin \theta \\ \frac{1}{\rho_1} & \cos \theta_1 & \sin \theta_1 \\ \frac{1}{\rho_2} & \cos \theta_2 & \sin \theta_2 \end{vmatrix} = 0.$$

41. Equation in terms of the \perp on the line, from the pole and the angle which it makes with the initial line.

The \perp OD = p ,

\angle DOC = α ,

OA is the initial line.

$$\frac{OD}{OP} = \cos \text{POD},$$

or $\frac{p}{\rho} = (\cos \theta - \alpha).$

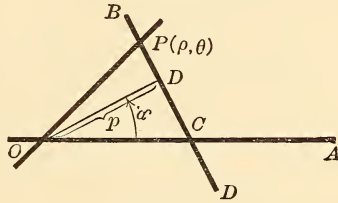

Fig. 77.

$$\therefore \rho = \frac{p}{\cos(\theta - \alpha)},^*$$

which is the equation required.

DISCUSSION. (1) If the given line CB is \perp to the initial line $\alpha = 0$, and the equation becomes

$$\rho = \frac{p}{\cos \theta},$$

which is the equation of a line perpendicular to the initial line.

* NOTE. — This equation

$$p = \rho \cos(\theta - \alpha)$$

gives

$$p = \rho [\cos \theta \cos \alpha + \sin \theta \sin \alpha]$$

$$= (\rho \cos \theta) \cdot \cos \alpha + (\rho \sin \theta) \cdot \sin \alpha,$$

$$\therefore p = x \cos \alpha + y \sin \alpha,$$

which agrees with § 25.

- (2) When $\theta = 0$, $\rho = \frac{p}{\cos(-\alpha)} = \frac{OD}{\cos \text{AOD}} = OC$.
- (3) When $\theta = \alpha$, $\rho = \frac{p}{\cos 0^\circ} = p$.
- (4) When $\theta = \frac{\pi}{2} + \alpha$, $\rho = \frac{p}{0} = \infty$, for in this case the radius vector becomes parallel to the line.
- (5) When $\theta = 2\pi + \alpha$, $\rho = p$ (as it should be).
- (6) When $\theta = 2\pi$, $\rho = \frac{p}{\cos(-\alpha)} = OC$.
- (7) When AB passes through the pole 0, $p = 0$, which is 0 for every value of θ except $\frac{\pi}{2} + \alpha$, when ρ assumes the indeterminate form $\frac{0}{0}$.

EXERCISES.

- Find a line making an angle of 60° with the line $5x + 12y + 1 = 0$.
Ans. $y = \frac{12\sqrt{3} + 5}{5\sqrt{3} - 12}x + b$.
- Making an angle, $\tan^{-1} \frac{b}{a}$ with the line $\frac{x}{a} + \frac{y}{b} = 1$, and passing through the point $(\frac{1}{2}a, \frac{1}{2}b)$.
Ans. $y - \frac{b}{2} = \frac{2ab}{b^2 - a^2} \left(x - \frac{a}{2}\right)$.
- Show that the $\Delta (2, 1), (3, -2), (-4, -1)$ is a right Δ . Prove analytically that,
- The altitudes of a Δ are concurrent.
- The medians of a Δ are concurrent.
- The \perp bisectors of the sides are concurrent.
- The bisectors of the angles are concurrent.
- The orthocenter, centroid, and circum-center are collinear.
- Find the locus of a point whose distances from the lines
 $A_1x + B_1y + C_1 = 0$, $A_2x + B_2y + C_2 = 0$,
 are in the ratio $m : n$.
Ans. The line $n \frac{A_1x + B_1y + C_1}{\sqrt{A_1^2 + B_1^2}} = \pm m \frac{A_2x + B_2y + C_2}{\sqrt{A_2^2 + B_2^2}}$.
- Show that the angle between the lines $x - y\sqrt{3} + 1 = 0$ and $x + y\sqrt{3} - 2 = 0$ is 60° .

11. Show that the lines $6x + 4y = 0$ and $2x - 3y - 1 = 0$ are \perp to each other.

12. Show that $Ax + By + C_1 = 0$, and $Bx - Ay + C_2 = 0$, are \perp to each other.

13. Show the same of the lines $ax + by + c = 0$, and

$$\frac{x}{a} - \frac{y}{b} + c_1 = 0.$$

14. Find the \angle s between these pairs of lines.

$$(1) \quad 5y - 3x = 0, \quad y - 4x = 1. \quad \text{Ans. } 45^\circ.$$

$$(2) \quad 2x - 3y = 0, \quad 6x + 4y + 1 = 0. \quad \text{Ans. } 90^\circ.$$

$$(3) \quad y + x = 0, \quad (2 + \sqrt{3})y - x = 0. \quad \text{Ans. } 60^\circ.$$

$$(4) \quad y = kx, \quad (1 - k)y - (1 + k)x = 0. \quad \text{Ans. } 45^\circ.$$

15. Find the line through $(2, 3)$ and \perp to the line joining the points $(1, 2)$ and $(-3, -14)$.

16. Find the line through $(0, -1)$ and \perp to $x + y = 1$.

$$\text{Ans. } x - y = 1.$$

17. Find the line through the origin and \perp to the line $Ax + By + C = 0$.

$$\text{Ans. } Bx = Ay.$$

18. Find the distance of the line $h(x + h) + k(y + k) = 0$ from the origin.

$$\text{Ans. } \sqrt{h^2 + k^2}.$$

19. Also, the distance of $\frac{x}{h} + \frac{y}{k} = 1$ from origin.

$$\text{Ans. } \frac{hk}{\sqrt{h^2 + k^2}}.$$

20. Show that the origin is inside the Δ whose vertices are $(3, 4)$, $(2, -3)$, $(-2, -2\frac{1}{2})$.

21. Find the distance between the feet of the \perp s from the origin on the lines,

$$\left. \begin{aligned} 3x - 4y + 25 &= 0, \\ 12x + 5y - 169 &= 0. \end{aligned} \right\} \quad \text{Ans. } \sqrt{226}.$$

REVIEW EXERCISES.

1. Which quadrants do the following lines cut ?

$$(1) \quad y = 2x + 3. \quad (3) \quad y = -x - 5.$$

$$(2) \quad y = -5x + 8. \quad (4) \quad y = 2x - 3.$$

$$(5) \quad x - 5y - 9 = 0.$$

2. Reduce to the normal form the equation

$$3x + 4y - 15 = 0.$$

3. Axes make an $\angle 60^\circ$. Find a line, intercept on y -axis = 4, and at 30° to x -axis. *Ans.* $y - x - 4 = 0$.

4. Find the line through $(0, 0)$ and $(3, 2)$.

5. Find the intersection of lines

$$\left. \begin{aligned} 3y + 4x - 11 &= 0, \\ 4y + 3x - 10 &= 0. \end{aligned} \right\}$$

6. Find locus of a point equidistant from $(1, 1)$ and $(-1, -1)$.

$$\text{Ans. } x + y = 0.$$

7. Find a line equidistant from $x + 1 = 0$ and $x = 3$. *Ans.* $x = 1$.

8. Also equidistant from $y = k$ and $y = c$. *Ans.* $y = \frac{1}{2}(c + k)$.

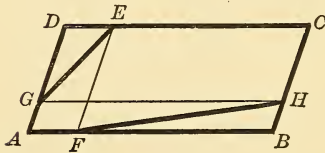

Fig. 78.

9. EF and GH are parallel to the sides of the \square . Find the locus of the intersection of GE and FH.

Ans. A diagonal.

SUGGESTION.—Take AB and AD as axes.

10. Find the bisectors of the angles between the lines

$$\left. \begin{aligned} 3x - 4y + 7 &= 0, \\ 12x + 5y - 5 &= 0. \end{aligned} \right\} \text{Ans. } \begin{aligned} 21x + 77y &= 116, \\ 33x - 9y &= -22. \end{aligned}$$

11. Show that one of the bisectors of the angles between the lines

$$\left. \begin{aligned} 3x - 4y &= 5, \\ 5x + 12y &= 13, \end{aligned} \right\}$$

passes through the origin.

12. Find the bisectors of the angles between the lines

$$\left. \begin{aligned} 4x + 3y &= 3, \\ 5x - 12y &= 8. \end{aligned} \right\} \text{Ans. } \begin{aligned} 77x - 21y &= 79, \\ 27x + 99y + 1 &= 0. \end{aligned}$$

42. To determine the relative positions of two given points (x_1, y_1) and (x_2, y_2) with respect to the given line, $Ax + By + C = 0$. — Let us suppose that the line divides the distance between the points in the ratio of $m : n$. Then the co-ordinates of the point of division are,

$$x = \frac{mx_2 + nx_1}{m + n}, \quad y = \frac{my_2 + ny_1}{m + n}.$$

These must satisfy the equation $Ax + By + C = 0$.

Substituting these values and multiplying by $(m + n)$,

$$A(mx_2 + nx_1) + B(my_2 + ny_1) + C(m + n) = 0,$$

or, $m(Ax_2 + By_2 + C) = -n(Ax_1 + By_1 + C).$

$$\therefore \frac{m}{n} = -\frac{Ax_1 + By_1 + C}{Ax_2 + By_2 + C} \dots \dots \dots (1)$$

Now, if $(x_1, y_1), (x_2, y_2)$ are on the same side of the line, the distance between them is cut externally, $\therefore \frac{m}{n}$ is negative; $\therefore Ax_1 + By_1 + C$, and $Ax_2 + By_2 + C$, have like signs. If they are on opposite sides, $\frac{m}{n}$ is positive, and $\therefore Ax_1 + By_1 + C$, and $Ax_2 + By_2 + C$, have unlike signs. Hence two points $(x_1, y_1), (x_2, y_2)$ are on the same or opposite sides of $Ax + By + C = 0$ according as the results of substituting their co-ordinates in the sinister of the equation have like or unlike signs.

NOTE.—Observe that equation (1) gives the ratio into which the distance between the points is divided by the given line $Ax + By + C = 0$.

EXERCISES.

1. Find the area of the Δ formed by the lines

$$y = \pm x, x = c.$$

Ans. c^2 .

2. Show that the angle between the lines

$$\left. \begin{aligned} x + y\sqrt{3} &= 0, \\ x - y\sqrt{3} &= 0, \end{aligned} \right\} \text{ is } 60^\circ.$$

3. Find the line through $(4, 5)$ and parallel to $2x - 3y = 5$.

4. Show that the distance between the points $(1, 2), (4, 3)$, is bisected by the line joining $(2, 3)$ and $(4, 1)$.

5. Find the distance of the line $\frac{x}{2} + \frac{y}{3} = 1$ from origin.

6. Find the polar co-ordinates of the intersection of the lines

$$\left. \begin{aligned} \rho &= \frac{2a}{\left(\cos \theta - \frac{\pi}{2}\right)} \\ \rho &= \frac{a}{\cos \left(\theta - \frac{\pi}{6}\right)} \end{aligned} \right\} \text{Ans. } \begin{aligned} \rho &= 2a \\ \theta &= \frac{\pi}{2}. \end{aligned}$$

Show that they meet at an angle $\frac{\pi}{3}$.

7. Show that the area of the Δ whose sides are

$$\left. \begin{aligned} x + 2y - 5 &= 0, \\ 2x + y - 7 &= 0, \\ y - x - 1 &= 0, \end{aligned} \right\} \text{is } \frac{3}{2}.$$

8. Show that the line $4x + 5y = 6$ cuts the distance between $(3, -2)$, $(1, 2)$ in a point of trisection.

9. Show that the points $(1, -2)$ and $(0, 1)$ are on one side of the line in Ex. 8. Also show that the origin and the point $(1, 1)$ are on opposite sides of the line.

10. Show that the origin lies inside the Δ whose vertices are the points of intersection of the lines $5y - 4x - 1 = 0$, $x - 3y - 9 = 0$, $x + 9y - 9 = 0$. Prove the same of the point $(\frac{1}{2}, \frac{1}{2})$.

11. Find the bisectors of the angles between the lines

$$\left. \begin{aligned} 4y + 3x - 9 &= 0, \\ 12x - 5y + 6 &= 0. \end{aligned} \right\} \text{Ans. } \begin{cases} 99x + 27y - 87 = 0, \\ 3x - 11y + 21 = 0. \end{cases}$$

12. Show that the distance from the origin to the line

$$\rho = \frac{1}{3 \cos \theta + 4 \sin \theta} \text{ is } \frac{1}{5}.$$

Also, its distance from the point $\left(13, \tan^{-1} \frac{5}{12}\right)$ is 11.

Show also that the equations of these \perp s are

$$\theta = \tan^{-1} \frac{4}{3}, \text{ and } \rho = \frac{33}{3 \cos \theta + 4 \sin \theta}.$$

13. Find the angle between the lines $3x + y + 12 = 0$ and $x + 2y - 1 = 0$.

14. Find the distance from $(4, 5)$ to the line $4x + 5y = 2$.

15. Find the distance from $(1, 2)$ to $y - 5x = 18$.

16. If the axes make an angle of 60° , find the angle between the line $y - 2x - 5 = 0$ and the x -axis. Ans. $\tan^{-1} \frac{1}{2} \sqrt{3}$.

17. If the axes make an angle of 45° , find the angle between the lines $7x + 3y - 1 = 0$, $x + y + 2 = 0$.
Ans. $\tan^{-1} \frac{2\sqrt{2}}{5(\sqrt{2}-2)}$.

18. Show that the lines $x + y = m$, $x - y = n$, are \perp to each other whatever the angle between the axes.

19. Show that the lines in Ex. 17 make these angles with the x -axis, viz.,

$$\tan^{-1} \frac{7}{7 - 3\sqrt{2}},$$

$$\tan^{-1} \frac{1}{1 - \sqrt{2}}.$$

20. Find the locus of the vertex of a Δ having a given base and a given area.

21. Find the locus of a point equidistant from the points (x_1, y_1) and (x_2, y_2) .

43. Equations representing straight lines.—An equation whose dexter is zero, and whose sinister can be broken up into factors of the first degree, represents straight lines.

EXAMPLES. — 1. $2x^2 + xy - 3y^2 = 0$ represents two lines, for it may be written,
 $(2x + 3y)(x - y) = 0$.
 \therefore the lines are $2x + 3y = 0$, $x - y = 0$.

It is evident that the co-ordinates of all points on the two lines satisfy the given equation.

2. $2x^3 + ax^2 - 7a^2x - 6a^3 = 0$ represents three straight lines parallel to the y -axis, for it may be written $(x + a)(x - 2a)(2x + 3a) = 0$.

3. $2xy + 4x - 3y - 6 = 0$ represents two lines, for it may be written $(y + 2)(2x - 3) = 0$.

4. What is represented by the equation
 $(3x + 2y - 1)(2x + y - 3) = 0$?

44. A homogeneous equation of the n th degree represents n straight lines through the origin.—Take the equation,
 $Ax^n + Bx^{n-1}y + Cx^{n-2}y^2 + \dots + Ny^n = 0$.

Dividing by Ay^n , we get

$$\left(\frac{x}{y}\right)^n + \frac{B}{A}\left(\frac{x}{y}\right)^{n-1} + \frac{C}{A}\left(\frac{x}{y}\right)^{n-2} + \dots + \frac{N}{A} = 0.$$

Now if $m_1, m_2, m_3 \dots m_n$ denote the roots of this equation, then

$$\left(\frac{x}{y} - m_1\right)\left(\frac{x}{y} - m_2\right)\left(\frac{x}{y} - m_3\right) \dots \left(\frac{x}{y} - m_n\right) = 0.$$

Hence this represents n straight lines through the origin; viz., $x - m_1y = 0, x - m_2y = 0, x - m_3y = 0$, etc.

. EXAMPLE. — Show that the equation $A(y - y_1)^n + B(y - y_1)^{n-1}(x - x_1) + C(y - y_1)^{n-2}(x - x_1)^2 + \dots + N(x - x_1)^n = 0$ represents n straight lines through the point (x_1, y_1) .

45. The homogeneous equation of the second degree. — This represents two straight lines through the origin.

Take $Ax^2 + 2Hxy + By^2 = 0$.

Divide by x^2 , giving a quadratic in $\frac{y}{x}$, viz.,

$$B\left(\frac{y}{x}\right)^2 + 2H\left(\frac{y}{x}\right) + A = 0.$$

If m_1 and m_2 denote its roots, we have

$$m_1 = \frac{-H + \sqrt{H^2 - AB}}{B}, \quad m_2 = \frac{-H - \sqrt{H^2 - AB}}{B}.$$

Hence the equation represents the two lines

$$y = m_1x, \quad y = m_2x.$$

46. Angle between the lines $Ax^2 + 2Hxy + By^2 = 0$.

$$\begin{aligned} \tan \phi &= \frac{m_1 - m_2}{1 + m_1m_2} \\ &= \frac{2\sqrt{H^2 - AB}}{B} \div \left[1 + \frac{A}{B}\right] \\ &= \frac{2\sqrt{H^2 - AB}}{A + B}. \end{aligned}$$

- DISCUSSION. (1) If the lines are \perp , then $A + B = 0$.
 (2) If the lines are \parallel , then $H^2 - AB = 0$,

which makes the two lines coincident. This is also obvious since both lines pass through the origin.

NOTE.—A pair of lines through the origin at right angles to each other may be represented by $x^2 + \lambda xy - y^2 = 0$, where λ is a variable parameter.

47. The bisectors of the angles between the lines $Ax^2 + 2Hxy + By^2 = 0$.

Write the equations of the lines thus :

$$y = m_1x \dots \dots \dots (1)$$

$$y = m_2x \dots \dots \dots (2)$$

Then the equations of the angle bisectors are

$$\frac{y - m_1x}{\sqrt{1 + m_1^2}} - \frac{y - m_2x}{\sqrt{1 + m_2^2}} = 0 \dots \dots (3)$$

$$\frac{y - m_1x}{\sqrt{1 + m_1^2}} + \frac{y - m_2x}{\sqrt{1 + m_2^2}} = 0 \dots \dots (4)$$

These two bisectors may be represented by a single equation, whose dexter is zero, and sinister is the product of the sinisters of these equations, viz.,

$$\frac{(y - m_1x)^2}{1 + m_1^2} - \frac{(y - m_2x)^2}{1 + m_2^2} = 0 \dots \dots (5)$$

or $(m_2^2 - m_1^2)(y^2 - x^2) + 2(m_1m_2 - 1)(m_1 - m_2)xy = 0$ (6)

or $(m_2 + m_1)(y^2 - x^2) - 2(m_1m_2 - 1)xy = 0$ (7)

$$\therefore -\frac{2H}{B}(y^2 - x^2) - 2\left(\frac{A}{B} - 1\right)xy = 0 \dots (8)$$

$$\therefore \frac{x^2 - y^2}{A - B} = \frac{xy}{H} \dots \dots (9)$$

Equation (9) represents the two bisectors.

48. To Find the condition that the general equation of the second degree may represent a pair of straight lines. —

Let the equation be written,

$$Ax^2 + 2Hxy + By^2 + 2Gx + 2Fy + C = 0 \quad (1)$$

$$\therefore Ax^2 + 2(Hy + G)x + By^2 + 2Fy + C = 0.$$

Solve for x , obtaining,

$$\begin{aligned} Ax + Hy + G &= \pm \sqrt{(Hy + G)^2 - A(By^2 + 2Fy + C)} \\ &= \pm \sqrt{(H^2 - AB)y^2 + 2(GH - AF)y + G^2 - AC}. \end{aligned}$$

The expression under the radical is a perfect square if

$$(H^2 - AB)(G^2 - AC) = (GH - AF)^2,$$

or, $ABC + 2FGH - AF^2 - BG^2 - CH^2 = 0.$

This expression is called the **discriminant** of (1), and is usually denoted by the symbol Δ (delta). It may be easily remembered in the determinant form, viz.,

$$\Delta = \begin{vmatrix} A & H & G \\ H & B & F \\ G & F & C \end{vmatrix} = 0.$$

Hence this is the condition that (1) the general equation of the second degree may represent a pair of straight lines.

EXAMPLE. — Determine k so that the equation

$$x^2 + kxy + 5y^2 - 6y + 4x + 5 = 0$$

may represent two straight lines.

EXERCISES.

1. Show that the line joining the points $(3 \cos \alpha, 2 \alpha)$ and $(3 \cos 2 \alpha, 3 \alpha)$ is $\rho = 3 \cos(\theta - \alpha)$.

2. Show that the line from $(\rho_1, \theta_1) \perp$ to $\rho = \frac{a}{\cos(\theta - \alpha)}$ is, $\rho \sin(\alpha - \theta) = \rho_1 \sin(\alpha - \theta_1)$.

3. Show that $y + x = 0$ and $y - x = 0$ are always \perp .

4. If the axes make an angle of 30° , find equation of the line making 105° with x -axis. *Ans.* $x + y - 1 = 0$.

5. Find the angle between the lines

$$\left. \begin{aligned} 7y - 17x - 1 &= 0. \\ y - x - 2 &= 0. \end{aligned} \right\} \quad \text{Ans. } \cos^{-1} \frac{1}{3}.$$

6. Find the bisectors of the angles between the lines

$$3x^2 + 8xy + 3y^2 = 0. \quad \text{Ans. } x^2 - y^2 = 0.$$

Also, between the lines $3x^2 + 4xy - 5y^2 = 0$. *Ans.* $x^2 - 4xy - y^2 = 0$.

7. Show that the lines joining the origin to the points of intersection of $y = k(x - 4)$, and $y^2 = 4x$, are \perp .

SUGGESTION. — The lines are $k(x^2 - y^2) = xy$.

8. Show that $3x^2 + 2xy - 3y^2 = 0$ are two \perp lines,
and $x^2 + 2xy + y^2 - x - y - 6 = 0$ are two \parallel lines.

9. Determine k so that $6xy - 2x + ky + 5 = 0$ may be two straight lines. *Ans.* $k = -15$.

10. Show that the lines $Ax^2 + 2Hxy + By^2 = k(x^2 + y^2)$ are equally inclined to the lines

$$Ax^2 + 2Hxy + By^2 = 0.$$

NOTE. — Observe that they have the same angle-bisectors.

49. Lines through the point of intersection of two given lines. — If $S_1 = 0$ and $S_2 = 0$, represent the equations of any two loci, then the locus of $S_1 + kS_2 = 0$ passes through all the points of intersection of the two given loci; for the co-ordinates of any points common to both evidently satisfy the last equation.

This principle may be applied to the straight line as follows:

EXAMPLE. — 1. Find the equation of the straight line joining the point (1, 2) to the intersection of the lines

$$x - 2y + 6 = 0 \quad \dots \dots \dots (1)$$

and $2x + y = 0 \quad \dots \dots \dots (2)$

Let the required equation be

$$(x - 2y + 6) + k(2x + y) = 0 \quad \dots \dots \dots (3)$$

which evidently may represent any line of a pencil passing through the point of intersection of (1) and (2). We may find the required line by determining for what value of k (3) will pass through the given point (1,2).

Substituting its co-ordinates in (3), we get

$$1 - 4 + 6 + 2k + 2k = 0,$$

whence,

$$k = -\frac{3}{4}.$$

$$\therefore (x - 2y + 6) + (-\frac{3}{4})(2x + y) = 0$$

is the equation required. It passes through the point (1, 2) and through the intersection of the lines (1) and (2).

NOTE 1. — If we desire the equation of the line passing through the point of intersection of the lines

$$S_1 = 0 \dots \dots \dots (1)$$

$$S_2 = 0 \dots \dots \dots (2)$$

and parallel or perpendicular to a third given line

$$S_3 = 0 \dots \dots \dots (3)$$

we assume the required equation as before, viz.,

$$S_1 + kS_2 = 0 \dots \dots \dots (4)$$

We find the slope of (4) in terms of k , and then ascertain for what value of k the line (4) will be perpendicular or parallel (as the case may be) to the line (3). Equation (4) (with the value for k substituted) will then be the required equation.

NOTE 2. — The angle bisectors of the lines

$$S_1 = 0, S_2 = 0, \text{ are } S_1 \pm S_2 = 0, \text{ or } S_1 \mp S_2 = 0.$$

50. To find the equations of two lines drawn from the origin to the points of intersection of the line

$$\frac{x}{a} + \frac{y}{b} = 1 \dots \dots \dots (1)$$

with the locus of the general equation of the second degree,

$$Ax^2 + 2Hxy + By^2 + 2Gx + 2Fy + C = 0 \dots (2)$$

Consider the equation,

$$Ax^2 + 2Hxy + By^2 + 2(Gx + Fy)$$

$$\left(\frac{x}{a} + \frac{y}{b}\right) + C\left(\frac{x}{a} + \frac{y}{b}\right)^2 = 0 \dots \dots \dots (3)$$

It evidently passes through the points of intersection of the given loci, for values which satisfy (1) and (2) satisfy (3).

Again, (3) represents a pair of straight lines through the origin, since it is homogeneous and of the second degree.

Hence equation (3) represents a pair of straight lines joining the origin to the points of intersection of (1) and (2).

51. The line at infinity. The intercepts of the line

$$Ax + By + C = 0 \text{ are } -\frac{C}{A}, -\frac{C}{B}, \text{ respectively.}$$

DISCUSSION (1). — Now suppose A becomes very small; then $-\frac{C}{A}$ becomes numerically very large. When $A = 0$, $\frac{C}{A} = \infty$, and the line becomes parallel to the x -axis.

(2) If both A and B become very small, the line has very large intercepts.

(3) If $A = 0$, and $B = 0$, both intercepts become infinite, and the line is situated altogether at infinity. Its equation then becomes $C = 0$, or k (a constant) $= 0$, which is the usual form of the equation of the line at infinity.

52. Parallel lines meet at infinity. Let any two lines be given, as,

$$Ax + By + C = 0 \quad \dots \quad (1)$$

$$A_1x + B_1y + C_1 = 0 \quad \dots \quad (2)$$

Then the equation of the line at infinity is,

$$0 \cdot x + 0 \cdot y + C_2 = 0 \quad \dots \quad (3)$$

The condition that these three lines be concurrent is

$$\begin{vmatrix} A & B & C \\ A_1 & B_1 & C_1 \\ 0 & 0 & C_2 \end{vmatrix} = 0, \quad \text{or} \quad \begin{vmatrix} A & B \\ A_1 & B_1 \end{vmatrix} = 0,$$

but this is evidently also the condition that (1) and (2) be parallel. Hence parallels meet at infinity.

EXERCISES.

1. Find the line through (a, b) and the intersection of

$$\left. \begin{aligned} \frac{x}{a} + \frac{y}{b} &= 1, \\ \frac{x}{b} + \frac{y}{a} &= 1, \end{aligned} \right\}$$

$$\text{Ans. } \frac{x}{a^2} - \frac{y}{b^2} = \frac{1}{a} - \frac{1}{b}.$$

2. Find the line through the point of intersection of

$$\left. \begin{aligned} y - 4x - 1 &= 0, \\ 2x + 5y - 6 &= 0, \end{aligned} \right\} \text{ and } \perp \text{ to } 4x + 3y = 0.$$

$$\text{Ans. } 88y - 66x = 101.$$

3. Show that the angle between the lines

$$x^2 - 2xy \sec \theta + y^2 = 0 \text{ is } \theta.$$

Also, the angle between the lines

$$6x^2 - xy - y^2 = 0 \text{ is } 45^\circ.$$

4. Find the line from $(0, 3)$ to the point of intersection of

$$\left. \begin{aligned} y - x - 1 &= 0, \\ y - 2x - 2 &= 0. \end{aligned} \right\} \text{ Ans. } y - 3x - 3 = 0.$$

5. Find the line joining the points (ρ_1, θ_1) and $\left(2\rho_1, \theta_1 + \frac{\pi}{3}\right)$.

$$\text{Ans. } \rho = \frac{\rho_1}{\cos(\theta - \theta_1)}.$$

6. If the angle between the axes is ψ , show that the line through (h, k) and \perp to the x -axis is

$$x + y \cos \psi = h + k \cos \psi.$$

7. Find the distance from (b, a) on $\frac{x}{a} + \frac{y}{b} = 1$.

8. If the axes are inclined at 60° , show that the distance from $(3, -4)$ to $4x + 2y = 7$ is $\frac{3}{4}$.

9. Show that the equation, $\sin 3\theta = 1$, represents three lines through the origin and making angles of $30^\circ, 150^\circ, 270^\circ$, with x -axis.

NOTE on imaginary loci. The locus of the equation $x^2 + y^2 = 0$ is manifestly imaginary, for x^2 and y^2 are positive, \therefore their sum cannot equal zero. The only point satisfying the equation is $x = 0, y = 0$. Hence this equation is sometimes used to represent the origin; or it may stand for the "point-circle," *i.e.*, a circle whose center is at the origin, and radius is 0. Also, since it may be written $(x + y\sqrt{-1})(x - y\sqrt{-1}) = 0$, it represents two imaginary straight lines. The equation

$$(x - y + 1)^2 + (2x + y - 2)^2 = 0$$

represents a point found by treating these equations as simultaneous, *viz.*,

$$x - y + 1 = 0 \quad \dots \dots \dots (1)$$

$$2x + y - 2 = 0 \quad \dots \dots \dots (2)$$

or two straight lines $(x - y + 1) = \pm \sqrt{-1} (2x + y - 2)$.

The equation $9(2x - y - 5)^2 + 5(x - y + 3)^2 = 0$ represents a point found as above, or two imaginary straight lines; *viz.*,

$$3(2x - y - 5) + \sqrt{-5}(x - y + 3) = 0 \quad \dots \quad (1)$$

$$3(2x - y - 5) - \sqrt{-5}(x - y + 3) = 0 \quad \dots \quad (2)$$

NOTE on concurrent lines. If $S_1 = 0$, $S_2 = 0$, $S_3 = 0$, are the equations of three loci, and if we can find three quantities l , m , and n , so that the sum $lS_1 + mS_2 + nS_3$ vanishes identically, i.e., is equal to zero, then the three loci meet in a point; for any points common to any two of these loci will lie on the third, since they will satisfy the equation

$$lS_1 + mS_2 + nS_3 = 0.$$

This fact will sometimes be found very serviceable in the study of the straight line.

EXERCISES ON CHAPTER IV *

1. Show that the area of the Δ formed by the lines

$$\left. \begin{aligned} y &= m_1x + c_1, \\ y &= m_2x + c_2, \\ y &= m_3x + c_3, \end{aligned} \right\} \text{ is } \frac{1}{2} \left\{ \frac{(c_2 - c_3)^2}{m_2 - m_3} + \frac{(c_3 - c_1)^2}{m_3 - m_1} + \frac{(c_1 - c_2)^2}{m_1 - m_2} \right\}.$$

Obtain also the following expression for area :

$$\frac{\begin{vmatrix} 1 & m_1 & c_1 \\ 1 & m_2 & c_2 \\ 1 & m_3 & c_3 \end{vmatrix}^2}{2(m_1 - m_2)(m_2 - m_3)(m_3 - m_1)}.$$

2. Show that the area of the Δ formed by the lines

$$\left. \begin{aligned} A_1x + B_1y + c_1 &= 0, \\ A_2x + B_2y + c_2 &= 0, \\ A_3x + B_3y + c_3 &= 0, \end{aligned} \right\} \text{ is } \frac{1}{2} \begin{vmatrix} A_1 & B_1 & C_1 \\ A_2 & B_2 & C_2 \\ A_3 & B_3 & C_3 \end{vmatrix}^2 \div \\ (A_1B_2 - B_1A_2)(A_2B_3 - B_2A_3)(A_3B_1 - A_1B_3).$$

3. Show that the area of the Δ formed by the y -axis and the lines

$$\left. \begin{aligned} y &= m_1x + c_1, \\ y &= m_2x + c_2, \end{aligned} \right\} \text{ is } \frac{(c_2 - c_1)^2}{2(m_2 - m_1)}.$$

4. Show that the area of the Δ whose sides are

$$\left. \begin{aligned} x - x_1y + ax_1^2 &= 0, \\ x - x_2y + ax_2^2 &= 0, \\ x - x_3y + ax_3^2 &= 0, \end{aligned} \right\} \text{ is } \frac{1}{2} a^2 \{ (x_1 - x_2)(x_2 - x_3)(x_3 - x_1) \}.$$

* It is expected, that from the lists of exercises given in this book, the teacher will make his *selections* according to the needs of his class and the time at their disposal.

5. Show that the area of the Δ whose sides are

$$\left. \begin{aligned} \frac{x}{a} - \frac{y}{b} &= 0, \\ \frac{x}{a} + \frac{y}{b} &= 0, \\ \frac{x}{a} \sec \theta - \frac{y}{b} \tan \theta &= 1, \end{aligned} \right\} \text{ is } ab.$$

6. Show that the distances from the origin to the bisectors of the angles between the lines

$$\left. \begin{aligned} x \cos \alpha + y \sin \alpha &= p, \\ x \cos \beta + y \sin \beta &= p', \end{aligned} \right\}$$

are $\frac{p - p'}{2 \sin \frac{1}{2}(\alpha - \beta)}$ and $\frac{p + p'}{2 \cos \frac{1}{2}(\alpha - \beta)}$.

7. Show that the distance from the origin to the line joining the points (ρ_2, θ_2) and (ρ_1, θ_1) is

$$\frac{\rho_1 \rho_2 \cdot \sin(\theta_2 - \theta_1)}{\sqrt{\rho_1^2 + \rho_2^2 - 2\rho_1 \rho_2 \cos(\theta_2 - \theta_1)}}.$$

8. Show that the area of the parallelogram whose sides are

$$\left. \begin{aligned} A_1 x + B_1 y + C_1 &= 0, \\ A_2 x + B_2 y + C_2 &= 0, \end{aligned} \right\} \left\{ \begin{aligned} A_1 x + B_1 y + C_1 + k_1 &= 0, \\ A_2 x + B_2 y + C_2 + k_2 &= 0, \end{aligned} \right.$$

is

$$\frac{k_1 k_2}{A_1 B_2 - A_2 B_1}.$$

9. Show that the equation of the line joining the points $(2k \cos \alpha, \alpha)$ and $(2k \cos \beta, \beta)$ is

$$\rho = \frac{2k \cos \alpha \cos \beta}{\cos(\beta + \alpha - \theta)}.$$

10. Prove that the lines $y = m_1 x + c_1$, $y = m_2 x + c_2$, are equally inclined [in opposite directions] to the x -axis if

$$\frac{1}{m_1} + \frac{1}{m_2} = -2 \cos \phi,$$

where ϕ is \angle between axes.

11. Show that the line joining the point of intersection of

$$\left. \begin{aligned} A_1 x + B_1 y + C_1 &= 0, \\ A_2 x + B_2 y + C_2 &= 0, \end{aligned} \right\} \text{ to that of}$$

$$\left. \begin{aligned} A_3 x + B_3 y + C_3 &= 0, \\ A_4 x + B_4 y + C_4 &= 0, \end{aligned} \right\} \text{ is}$$

$$A_1 x + B_1 y + C_1 + k(A_2 x + B_2 y + C_2) = 0.$$

Where k is determined by the equation,

$$k \begin{vmatrix} A_2 & B_2 & C_2 \\ A_3 & B_3 & C_3 \\ A_4 & B_4 & C_4 \end{vmatrix} + \begin{vmatrix} A_1 & B_1 & C_1 \\ A_3 & B_3 & C_3 \\ A_4 & B_4 & C_4 \end{vmatrix} = 0.$$

12. Show that the line from (ρ_1, θ_1) and \perp to the line

$$\rho = \frac{1}{a \cos \theta + b \sin \theta}$$

is

$$\frac{\rho_1}{\rho} = \frac{b \cos \theta - a \sin \theta}{b \cos \theta_1 - a \sin \theta_1}.$$

13. Show that the angle between the lines

$$3x^2 + xy - 2y^2 + x + 6y - 4 = 0 \text{ is } \tan^{-1} 5.$$

14. Show that the equation $\tan 3\theta = 1$ represents three lines through the origin, viz., $\theta = 15^\circ, 75^\circ$, or 135° .

15. Show that the condition that the line

$$A_1x + B_1y + C_1 = 0$$

may pass through the intersection of the lines

$$Ax^2 + 2Hxy + By^2 + 2Gx + 2Fy + C = 0$$

is

$$\begin{vmatrix} A & H & G \\ H & B & F \\ A_1 & B_1 & C_1 \end{vmatrix} = 0.$$

NOTE. — Observe that the points of intersection of the two given lines (if the given equation represents lines) are determined by any two of the equations

$$Ax + Hy + G = 0,$$

$$Hx + By + F = 0,$$

$$Gx + Fy + C = 0.$$

16. Show that the equation

$$x^2 + 2xy \cos \phi + y^2 \cos 2\phi = 0$$

represents two straight lines at 45° , and 135° to the x -axis [where ϕ is the \sphericalangle between the axes].

17. Show that the pair of lines joining the origin to the points of intersection of

$$x^2 + y^2 - 2x - 4y - 31 = 0,$$

and

$$x + y - 2 = 0,$$

is

$$31x^2 + 74xy + 35y^2 = 0.$$

18. Find the line joining the origin to the intersection of the lines

$$A_1x + B_1y + C_1 = 0, \quad A_2x + B_2y + C_2 = 0.$$

$$\text{Ans. } (A_1C_2 - A_2C_1)x + (B_1C_2 - B_2C_1)y = 0.$$

19. The line

$$\frac{x}{a} + \frac{y}{b} = 1$$

moves so that

$$\frac{1}{a} + \frac{1}{b} = k \text{ [a constant].}$$

Show that the line always passes through the fixed point $\left(\frac{1}{k}, \frac{1}{k}\right)$.

20. From P (h, k) \perp s are drawn [PM and PN] to the axes inclined at an $\angle \phi$.

$$\text{Prove, } MN = \sin \phi \sqrt{h^2 + k^2 - 2hk \cos \phi}$$

and the equation of the \perp from P on MN is

$$hx - ky - h^2 + k^2 = 0.$$

21. A line revolves about the origin and cuts the lines

$$A_1x + B_1y + C_1 = 0, \quad A_2x + B_2y + C_2 = 0,$$

in P and Q respectively. A point R is taken in the revolving line such that $OR = OP + OQ$ [O is origin]. Show that the locus of R is

$$\{A_1x + B_1y + C_1\} \{A_2x + B_2y + C_2\} = C_1C_2.$$

22. Show that the equation

$$x^2 + kxy + y^2 - 5x - 7y + 6 = 0$$

will represent two straight lines if $k = \frac{5}{2}$ or $\frac{1}{3}$.

23. Find the line joining the origin to the point of intersection of the lines

$$\frac{x}{a} + \frac{y}{b} = 1,$$

$$\frac{x}{b} + \frac{y}{a} = 1.$$

24. Show that the lines $Ax^2 + 2Hxy + By^2 = 0$
are \perp to the lines $Bx^2 - 2Hxy + Ay^2 = 0$.

25. Show that the product of the \perp s from (h, k) on the lines $Ax^2 + 2Hxy + By^2 = 0$ is

$$\frac{Ah^2 + 2Hhk + Bk^2}{\sqrt{(A - B)^2 + 4H^2}}.$$

26. Show that the equation

$$(h^2 + k^2 - 1)(x^2 + y^2 - 1) = (hx + ky - 1)^2$$

represents a pair of straight lines.

27. Show that the equations

$$A \tan \theta + B \sec \theta = 1 \quad \dots \dots \dots (1)$$

and $A \sec \theta + B \tan \theta = 1 \quad \dots \dots \dots (2)$

represent pairs of straight lines.

SUGGESTION. — Transform to rectangular axes.

Show, also, that the condition that the lines (1) should be the bisectors of the angles between (2)

is $A^2 - 2B^2 + 1 = 0,$
and $(1 - B^2)^2 + 2AB = 0.$

28. Find the points of intersection of the lines

$$\rho = \frac{a}{\cos\left(\theta - \frac{\pi}{3}\right)}, \quad \rho = \frac{a}{\cos\left(\theta - \frac{\pi}{6}\right)}.$$

Ans. $\left(\frac{a}{\cos 15^\circ}, \frac{\pi}{4}\right).$

And of the lines

$$\rho = a \sin \theta, \quad \rho \cos\left(\theta - \frac{\pi}{2}\right) = \frac{3}{4}a. \quad \text{Ans. } \left(\frac{a}{2}\sqrt{3}, \frac{\pi}{3}\right).$$

29. Prove that the distance between the points of intersection of the line

$$x \cos \alpha + y \sin \alpha = p$$

with the lines

$$Ax^2 + 2Hxy + By^2 = 0.$$

is
$$\frac{2p\sqrt{H^2 - AB}}{A \sin^2 \alpha - 2H \sin \alpha \cos \alpha + B \cos^2 \alpha}.$$

30. Show that the lines

$$A^2x^2 + 2H(A+B)xy + B^2y^2 = 0$$

are equally inclined to the lines

$$Ax^2 + 2Hxy + By^2 = 0.$$

31. The line $lx + my + n = 0$ meets the lines $Ax^2 + 2Hxy + By^2 = 0$ at angles α and β .

Prove:
$$\tan \alpha + \tan \beta = 2 \frac{(A - B)lm - H(l^2 - m^2)}{Al^2 + 2Hlm + Bm^2}.$$

QUERY. — Why does the quantity n not enter into the result?

CHAPTER V

THE CIRCLE

53. Equation of the circle whose center is the point (h, k) , and radius r . —

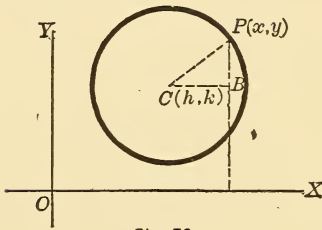

Fig. 79.

$P(x, y)$ is any point on the circle.*

$$\text{Then } \overline{CP}^2 = \overline{CB}^2 + \overline{PB}^2$$

$$\text{or, } r^2 = (x - h)^2 + (y - k)^2.$$

$$\therefore (x - h)^2 + (y - k)^2 = r^2$$

is the required equation of the circle.

54. Special positions of center. —

(1) If the center is at the origin,

$$h = 0, \quad k = 0,$$

and the above equation becomes

$$x^2 + y^2 = r^2.$$

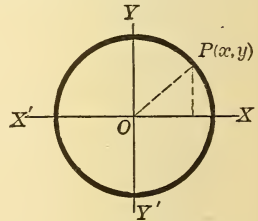

Fig. 80.

This is also evident from the figure given here.

(2) When the circle passes through the origin and has its center on the x -axis to the right of the origin, $r = h, k = 0$, and the equation becomes

$$(x - r)^2 + y^2 = r^2$$

$$\text{or, } x^2 + y^2 = 2rx.$$

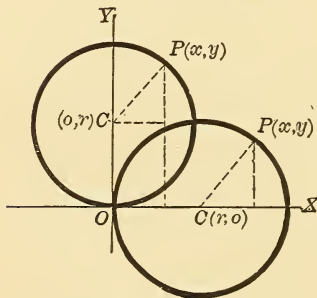

Fig. 81.

* Circle, in this chapter, means circumference.

(3) When the center is on the y -axis above the origin, and the circle passes through the origin, we have $h = 0$, $r = k$.

∴ the equation is $x^2 + (y - r)^2 = r^2$
 or, $x^2 + y^2 = 2ry$

QUERY.—What \odot s are represented by the equations $x^2 + y^2 = -2rx$, $x^2 + y^2 = -2ry$?

55. Every equation of the form $x^2 + y^2 + 2Gx + 2Fy + C = 0$ represents a circle. — For this may be written thus:

$$x^2 + 2Gx + G^2 + y^2 + 2Fy + F^2 = G^2 + F^2 - C.$$

$$\therefore (x + G)^2 + (y + F)^2 = G^2 + F^2 - C.$$

Comparing this equation with $(x - h)^2 + (y - k)^2 = r^2$, we see that it represents a circle whose center is the point $(-G, -F)$ and whose radius is $\sqrt{G^2 + F^2 - C}$. Hence, an equation of the second degree in rectangular co-ordinates represents a circle if,

(1) The term in xy is absent, and (2) the coefficients of x^2 and y^2 are equal.

NOTE 1. We generally make the coefficients of x^2 and y^2 unity by division if necessary.

NOTE 2. The equation of the circle with center $(r, 0)$ and radius r may also be found as follows:

$$\overline{PD}^2 = OD \times DA,$$

or, $y^2 = x(2r - x),$

whence $x^2 + y^2 = 2rx.$

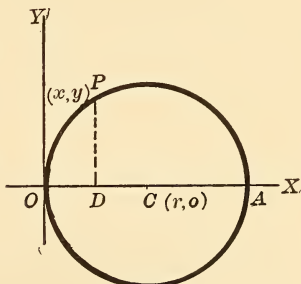

Fig. 82.

56. The conditions determining a circle. — Three conditions determine a circle, *e.g.*, three given points through which

it is to pass. Let the circle be $x^2 + y^2 + 2Gx + 2Fy + C = 0$, then the co-ordinates of each point, when substituted herein, give a relation between G , F , and C . Hence, from three relations (equations) G , F , and C may be found.

EXAMPLE.—Find the circle through the three points (o, o) , (a, o) , (o, b) .

We get by substitution,

$$C = 0 \quad \dots (1)$$

$$C = 0$$

$$a^2 + 2Ga + C = 0 \quad \dots (2)$$

$$G = -\frac{a}{2}$$

$$b^2 + 2bF + C = 0 \quad \dots (3)$$

$$F = -\frac{b}{2}$$

\therefore the equation of the required circle is $x^2 + y^2 = ax + by$. Similarly the circle through any three given points may be found.

57. **Oblique axes. Equation of circle.**—If in § 53 the axes are inclined at an angle ϕ , the equation of the circle whose center is (h, k) and radius r , is,

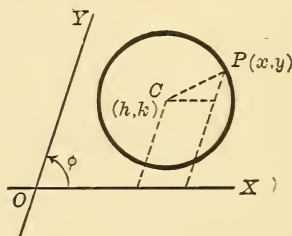

Fig. 83.

$$(x - h)^2 + (y - k)^2 + 2(x - h)(y - k) \cos \phi = r^2 \quad (1)$$

Expanding, the second-degree terms are $x^2 + y^2 + 2xy \cos \phi$.
 \therefore the most general form of the equation to a circle is

$$A(x^2 + y^2 + 2xy \cos \phi) + 2Gx + 2Fy + C = 0 \quad (2)$$

We may find its center thus: Divide through by A , and compare coefficients with those of equation (1) above.

We get $\frac{G}{A} = -h - k \cos \phi, \quad \frac{F}{A} = -k - h \cos \phi,$

$$\frac{C}{A} = h^2 + k^2 + 2hk \cos \phi - r^2.$$

Solving these three equations, we find $h, k,$ and $r.$

NOTE.—The above equations are seldom, if ever, used. In general, it is easier to study curves from their equations referred to rectangular axes. Oblique axes give rise to very complicated formulæ which are useless for practical purposes. These formulæ are derived in text-books for the sake of completeness.

58. Definitions of tangent, normal, subtangent, sub-normal.—If a secant PQ of any curve revolve about one of the points of intersection P until the point Q moves up to coincidence with P , the limiting position PT of the secant PQ is called a **tangent** to the curve at P . The line $PS \perp$ to the tangent PT at P is called the **normal** to the curve at P . The distance MN is called the **subtangent**, and MR the **sub-normal**.

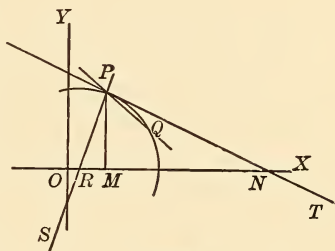

Fig. 84.

NOTE.—The idea of tangency should be clearly explained by the teacher.

59. Equation of the tangent to the circle $x^2 + y^2 = r^2$ at the point $(x_1, y_1).$ —Let P be $(x_1, y_1),$ and Q an adjacent point on the circle $(x_2, y_2).$

Equation of chord PQ is $\frac{y - y_1}{x - x_1} = \frac{y_1 - y_2}{x_1 - x_2} (1)$

If Q approaches $P,$ then ultimately $y_1 - y_2 = 0, x_1 - x_2 = 0,$

and the dexter of (1) assumes the indeterminate form $\frac{0}{0}$. The difficulty is removed by the consideration that P and Q always are on the circle.

$$\therefore x_1^2 + y_1^2 = r^2 \quad (2)$$

$$x_2^2 + y_2^2 = r^2 \quad (3)$$

or, $(x_1^2 - x_2^2) + (y_1^2 - y_2^2) = 0 \quad (4)$

whence $(x_1 - x_2)(x_1 + x_2) = -(y_1 - y_2)(y_1 + y_2)$.

$$\therefore \frac{y_1 - y_2}{x_1 - x_2} = -\frac{x_1 + x_2}{y_1 + y_2}.$$

(1) becomes $\therefore \frac{y - y_1}{x - x_1} + \frac{x_1 + x_2}{y_1 + y_2} = 0. \quad (5)$

which is the equation of secant PQ.

This will become a tangent at P if $x_1 = x_2, y_1 = y_2$.

Making this substitution, and clearing of fractions, we get

$$yy_1 - y_1^2 + xx_1 - x_1^2 = 0,$$

or, $xx_1 + yy_1 = x_1^2 + y_1^2 = r^2.$

\therefore the required equation of the tangent at (x_1, y_1) is

$$xx_1 + yy_1 = r^2.$$

EXERCISES.

Find the equations of the following circles :

1. Center (4, - 5), radius 3.
2. Center (1, 2), radius 7.
3. Center (- 5, - 3), radius 5.
4. Center (1, 0), radius 2.
5. Center (0, 0), radius 4.
6. Center (5, - 1), radius 1.
7. Center (0, 2), radius $\frac{3}{4}$.
8. Center (3, - 3), radius 6.

9. Center (h, k) , radius $\sqrt{h^2 + k^2}$. *Ans.* $x^2 + y^2 = 2hx + 2ky$.
10. Distance between $(1, -3)$ and $(3, 5)$ as diameter.
 Ans. $x^2 + y^2 - 4x - 2y - 12 = 0$.
11. In the first quadrant, touching both axes, and radius $= r$.
 Ans. $x^2 + y^2 - 2rx - 2ry + r^2 = 0$.

Find the centers and radii of the following circles :

12. $x^2 + y^2 + 12x - 6y = 0$.
13. $x^2 + y^2 - 3x - 9 = 0$.
14. $ax^2 + ay^2 = bx + cy$. *Ans.* $\left(\frac{b}{2a}, \frac{c}{2a}\right); \frac{1}{2a}\sqrt{b^2 + c^2}$.
15. $x^2 + y^2 - 4x + 4y - 1 = 0$.
16. $4(x^2 + y^2) + 12ax - 6ay - a^2 = 0$. *Ans.* $\left(-\frac{3a}{2}, \frac{3a}{4}\right); \frac{7a}{4}$.
17. $(x + y)^2 + (x - y)^2 - 8a^2 = 0$. *Ans.* $(0, 0); 2a$.
18. $\sec \phi (x^2 + y^2) - 2ax - 2ay \tan \phi = 0$.
 Ans. $(a \cos \phi, a \sin \phi); a$.
19. $x^2 + y^2 + 2x + 2y + 1 = 0$.
20. $3(x^2 + y^2) - 8x - 6y + 4 = 0$.
21. Show that the circle $x^2 + y^2 + 2x + 2y + 1 = 0$ touches both axes, and find the points of contact. *Ans.* $(-1, 0), (0, -1)$.
22. Find the equation of the circle through the points $(2, 3), (1, -4), (2, -5)$.
23. Through $(1, 2), (4, -5), (-1, -1)$.
24. Through $(0, 0), (a, b)$, and (b, a) .
 Ans. $(a + b)(x^2 + y^2) - (a^2 + b^2)(x + y) = 0$.
25. Through $(1, 2)$ and $(4, 5)$ and having a radius 8.
26. Find the equation of the circle whose center is on the line
 $3x + 4y - 7 = 0$,
 and which touches the lines
 $x + y - 3 = 0$,
 $x - y - 3 = 0$.
 Ans. $9x^2 + 9y^2 - 42x + 47 = 0$.
27. Find the circle which touches both axes and passes through the point $(2, 6)$.
28. Show that the equation $9x^2 + 9y^2 - 42x + 38y - 59 = 0$ represents a circle.

Find the points of intersection of the following pairs of curves :

29. $x^2 + y^2 = 9, x + y - 1 = 0.$

30. $x^2 + y^2 = 6x, x = y.$

31. $x^2 + y^2 - 2x - 3y + 3 = 0, x - y + 1 = 0.$ *Ans.* (1, 2), $(\frac{1}{2}, \frac{3}{2}).$

32. $x^2 + y^2 - 2x - 4y - 3 = 0, x + y - 7 = 0.$ *Ans.* (3, 4) (3, 4).

Hence the line touches the \odot at that point.

33. Find the circle which touches both axes at a distance of 5 from the origin. *Ans.* $x^2 + y^2 - 10x - 10y + 25 = 0.$

34. Show that the circles, $x^2 + y^2 - 6x - 6y + 10 = 0$, and $x^2 + y^2 = 2$, touch each other, and find the point of contact. *Ans.* (1, 1).

35. A line of fixed length always has its extremities in the axes. Show that its mid-point describes a circle.

36. Find the equations of the tangents to the circle $x^2 + y^2 = 10$ at the points whose abscissa is 1. *Ans.* $x \pm 3y = 10.$

37. Two lines are drawn from $(a, 0)$ and $(-a, 0)$ to make an angle ϕ with each other. Show that the locus of its vertex is

$$x^2 + y^2 - a^2 = \pm 2ay \operatorname{ctn} \phi.$$

38. Given base = $2m$, and sum of squares of sides = $2S^2$ [in a Δ], find locus of vertex. *Ans.* $x^2 + y^2 + m^2 - S^2 = 0.$

39. Given [in a Δ] base = $2m$, vertical angle = ϕ , find the locus of the intersection of the altitudes on the two other sides.

$$\text{Ans. } x^2 + y^2 + 2my \operatorname{ctn} \phi - m^2 = 0.$$

40. Find the equation of the tangent from the origin to the circle $x^2 + y^2 - 3x + 4y = 0.$ *Ans.* $4y - 3x = 0.$

41. Find the equation of the tangent to the circle $x^2 + y^2 = 25$ at the point $(-3, 4).$

42. Find the radius of the circle $x^2 + y^2 - 6x - 8y + 25 = 0.$ *Ans.* 0.

43. For what value of k will the line $y = x + k$ touch the circle $x^2 + y^2 = 4$?

44. Find a tangent to the circle $x^2 + y^2 = 8x$ and parallel to the line $2x + 3y + 4 = 0.$

45. Also a tangent to the circle $x^2 + y^2 = 9$ and \perp to the line $x - y - 1 = 0.$

46. A tangent to the circle $x^2 + y^2 - 10x - 8y + 2 = 0$ and parallel to the line $x - 2y = 0.$

47. Show that the line $y = x + a\sqrt{2}$ always touches the circle $x^2 + y^2 = a^2$.

48. For what value of k will the line $2x - 3y + k = 0$ touch the circle $x^2 + y^2 - 8x - 8y + 12 = 0$?

49. Find the circle through $(2, 3)$, $(4, 5)$, and $(6, 1)$.

$$\text{Ans. } 3(x^2 + y^2) - 26x - 16y + 61 = 0.$$

50. Find the circle on the distance between (x_1, y_1) , (x_2, y_2) as a diameter.

$$\text{Ans. } (x - x_1)(x - x_2) + (y - y_1)(y - y_2) = 0.$$

51. Show that the line $4x + 3y - 35 = 0$ touches the circle

$$x^2 + y^2 - 2x - 4y - 20 = 0.$$

52. Find the length of the chord which the circle $x^2 + y^2 - 5x - 6y + 6 = 0$ intercepts on the x -axis.

$$\text{Ans. } 1.$$

53. Find the tangent to the circle $x^2 + y^2 = k^2$ which makes a Δ of area k^2 with the axes.

$$\text{Ans. } x + y = k\sqrt{2}.$$

54. Find the chord made by the line $y - x - 3 = 0$ on the circle $x^2 + y^2 - 2x - 2y - 23 = 0$.

$$\text{Ans. } \sqrt{82}.$$

55. Show that the line $b(y - b) - ax = 0$ touches the circle $x(x - a) + y(y - b) = 0$, and find point of contact.

$$\text{Ans. } (a, b).$$

56. Find the chord of the circle $x^2 + y^2 - 2x - 3y + 3 = 0$ made by the line $x - y + 1 = 0$.

$$\text{Ans. } \frac{1}{\sqrt{2}}.$$

57. A $(a, 0)$, B $(-a, 0)$, are two points. Find the locus of P such that $PB = n \cdot PA$.

$$\text{Ans. A circle, center } \left(\frac{n^2 + 1}{n^2 - 1} a, 0 \right), \text{ radius } \frac{2na}{n^2 - 1}.$$

58. A point P moves so that the sum of the squares of its distances from the sides of a square (side = a) is constant = $2k^2$. Find its locus. Take two adjacent sides of square as axes.

$$\text{Ans. } x^2 + y^2 - ax - ay + a^2 - k^2 = 0.$$

59. Find the circle through $(2, 3)$, $(3, 4)$, $(0, 0)$.

$$\text{Ans. } x^2 + y^2 - 23x + 11y = 0.$$

60. Find the locus of a point which moves so that the sum of the squares of its distances from the sides of an equilateral $\Delta = k^2$.

Let the vertices be $(-a, 0)$, $(a, 0)$, $(0, a\sqrt{3})$.

$$\text{Ans. } 6(x^2 + y^2) + 6a^2 - 4(k^2 + ay\sqrt{3}) = 0.$$

61. Find a tangent to the circle $x^2 + y^2 - 4x - 6y + 12 = 0$ and parallel to $3y - 4x + 2 = 0$.

SUGGESTION. — $3y - 4x + k = 0$ is the tangent required where k is to be found from the condition that the distance from center of \odot to the line = radius.

62. Find tangent from origin to $\odot x^2 + y^2 - 8x - 8y + 5 = 0$.

Ans. $y = kx$ where k is determined as above.

NOTE. — The tangent in Ex. 61 may also be found by eliminating y and finding k , so that the points of intersection are coincident.

63. Three tangents to the circle $x^2 + y^2 = 25$ form an equilateral Δ , and one of them is parallel to the x -axis. Find their equations.

$$\text{Ans. } \begin{cases} y + 5 = 0. \\ y - \sqrt{5} \cdot x - 10 = 0. \\ y + \sqrt{5} \cdot x - 10 = 0. \end{cases}$$

60. Equation of tangent at (x_1, y_1) to the circle $x^2 + y^2 + 2Gx + 2Fy + C = 0$. — The reasoning here is similar to that of the preceding article.

The equation of line PQ is

$$\frac{y - y_1}{x - x_1} = \frac{y_1 - y_2}{x_1 - x_2} \quad \dots \quad (1)$$

$$\text{Also, } x_1^2 + y_1^2 + 2Gx_1 + 2Fy_1 + C = 0 \quad \dots \quad (2)$$

$$x_2^2 + y_2^2 + 2Gx_2 + 2Fy_2 + C = 0 \quad \dots \quad (3)$$

By subtraction,

$$(x_1 - x_2)(x_1 + x_2 + 2G) + (y_1 - y_2)(y_1 + y_2 + 2F) = 0,$$

$$\text{or, } \frac{y_1 - y_2}{x_1 - x_2} = -\frac{x_1 + x_2 + 2G}{y_1 + y_2 + 2F}.$$

$$\therefore (1) \text{ becomes } \frac{y - y_1}{x - x_1} = -\frac{x_1 + x_2 + 2G}{y_1 + y_2 + 2F} \quad \dots \quad (4)$$

Now put $x_2 = x_1, y_2 = y_1$, and the equation to the tangent becomes

$$\frac{y - y_1}{x - x_1} = -\frac{x_1 + G}{y_1 + F}.$$

Clear of fractions, $(x - x_1)(x_1 + G) + (y - y_1)(y_1 + F) = 0$,

$$\therefore xx_1 + yy_1 + Gx + Fy = x_1^2 + y_1^2 + Gx_1 + Fy_1.$$

Add $Gx_1 + Fy_1 + C$ to both sides, giving,

$$\begin{aligned} xx_1 + yy_1 + G(x + x_1) + F(y + y_1) + C \\ = x_1^2 + y_1^2 + 2Gx_1 + 2Fy_1 + C \\ = 0 \text{ [since } (x_1, y_1) \text{ is on } \odot]. \end{aligned}$$

\therefore the equation of the tangent at (x_1, y_1) is

$$xx_1 + yy_1 + G(x + x_1) + F(y + y_1) + C = 0.$$

61. The Normals. — In § 59 the equation of the normal [$a \perp$ to the tangent at (x_1, y_1)] is

$$\frac{y - y_1}{y_1} = \frac{x - x_1}{x_1}$$

or,
$$x_1 y - y_1 x = 0 \quad (1)$$

which shows that the normal passes through the origin.

Otherwise, its equation is $y - y_1 = \frac{y_1}{x_1}(x - x_1)$.

[Slope of tangent is $-\frac{x_1}{y_1}$, hence slope of normal is $\frac{y_1}{x_1}$].

This equation also reduces to $x_1 y - y_1 x = 0$.

In § 60 the normal is $y - y_1 = \frac{y_1 + F}{x_1 + G}(x - x_1)$.

[Slope of tangent is $-\frac{x_1 + G}{y_1 + F}$, hence slope of normal is $\frac{y_1 + F}{x_1 + G}$].

The equation reduces to

$$x(y_1 + F) - y(x_1 + G) + Gy_1 - Fx_1 = 0,$$

which shows that the normal passes through the center.

These normals may also be found by assuming the previously known fact that they pass through the center.

Thus, for $\odot x^2 + y^2 = r^2$, the normal is the line joining the points $(0, 0)$ and (x_1, y_1) , *i.e.*,

$$\begin{vmatrix} x & y & 1 \\ x_1 & y_1 & 1 \\ 0 & 0 & 1 \end{vmatrix} = 0.$$

For the circle of §60, the line joining the points (x_1, y_1) and $(-G, -F)$, viz.,

$$\begin{vmatrix} x & y & 1 \\ x_1 & y_1 & 1 \\ -G & -F & 1 \end{vmatrix} = 0.$$

From these, the equations of the tangents may be found (lines \perp to these at x_1, y_1).

62. Tangent to the circle $(x - h)^2 + (y - k)^2 = r^2$ at point (x_1, y_1) . — If the circle be given in this form, the method of procedure is the same as in the two other cases.

Equation of PQ is $\frac{y - y_1}{x - x_1} = \frac{y_1 - y_2}{x_1 - x_2} \dots \dots \dots (1)$

Then also $(x_1 - h)^2 + (y_1 - k)^2 = r^2 \dots \dots \dots (2)$

$(x_2 - h)^2 + (y_2 - k)^2 = r^2 \dots \dots \dots (3)$

By subtraction,

$$(x_2 - x_1)(x_2 + x_1 - 2h) + (y_2 - y_1)(y_2 + y_1 - 2k) = 0.$$

Hence the secant becomes, from (1) above,

$$\frac{y - y_1}{x - x_1} = -\frac{x_2 + x_1 - 2h}{y_2 + y_1 - 2k}.$$

Now put $x_2 = x_1$, $y_2 = y_1$, and reduce and simplify, getting, as the required equation of the tangent,

$$(x_1 - h)(x - h) + (y_1 - k)(y - k) = r^2 \dots \dots (4)$$

The normal is found to be

$$(x - x_1)(y_1 - k) - (y - y_1)(x_1 - h) = 0 \dots \dots (5)$$

63. Equation of circle through three given points. Determinant form. — Let the points be (x_1, y_1) , (x_2, y_2) , and (x_3, y_3) .

Let the required circle be

$$x^2 + y^2 + 2 Gx + 2 Fy + C = 0.$$

Then $x_1^2 + y_1^2 + 2 G x_1 + 2 Fy_1 + C = 0 \dots (1)$

$$x_2^2 + y_2^2 + \dots = 0 \dots (2)$$

$$x_3^2 + y_3^2 + \dots \text{etc.} = 0 \dots (3)$$

Eliminating G, F, and C, we obtain the required equation, viz.,

$$\begin{vmatrix} x^2 + y^2 & x & y & 1 \\ x_1^2 + y_1^2 & x_1 & y_1 & 1 \\ x_2^2 + y_2^2 & x_2 & y_2 & 1 \\ x_3^2 + y_3^2 & x_3 & y_3 & 1 \end{vmatrix} = 0.$$

64. Condition for four concyclic points.—If the four points $(x_1, y_1), (x_2, y_2), \dots$ etc., lie on a circle, its equation is that found for any three of them; viz.,

$$\begin{vmatrix} x^2 + y^2 & x & y & 1 \\ x_2^2 + y_2^2 & x_2 & y_2 & 1 \\ x_3^2 + y_3^2 & x_3 & y_3 & 1 \\ x_4^2 + y_4^2 & x_4 & y_4 & 1 \end{vmatrix} = 0.$$

Now, if the fourth point (x_1, y_1) lie on this circle, we have

$$\begin{vmatrix} x_1^2 + y_1^2 & x_1 & y_1 & 1 \\ x_2^2 + y_2^2 & x_2 & y_2 & 1 \\ x_3^2 + y_3^2 & x_3 & y_3 & 1 \\ x_4^2 + y_4^2 & x_4 & y_4 & 1 \end{vmatrix} = 0,$$

as the condition that the four points be concyclic.

NOTE. — This result may also be obtained thus: By elementary geometry, the sum of the products of the opposite sides of a cyclic quadrilateral is equal to the product of the diagonals. Take for vertices $(x_1, y_1), (x_2, y_2), \text{etc.}$

65. Equation of tangent in terms of slope.—Let the line $y = mx + b$ intersect the circle $x^2 + y^2 = r^2$. Then, the

condition that it may touch the circle is the condition that it intersect it in two coincident points.

$$\begin{aligned} &\text{Eliminate } y, & x^2 + (mx + b)^2 &= r^2, \\ \text{or,} & & (1 + m^2)x^2 + 2bmx + b^2 - r^2 &= 0. \end{aligned}$$

This quadratic, which determines the abscissæ of the points of intersection, will be a perfect square, *i. e.*, will have equal roots, if

$$\begin{aligned} & & (1 + m^2)(b^2 - r^2) &= m^2b^2 \\ \text{or,} & & b^2 &= r^2(1 + m^2). \\ & & \therefore b &= \pm r\sqrt{1 + m^2}. \end{aligned}$$

Hence the line $y = mx \pm r\sqrt{1 + m^2}$ is a tangent to the circle for all values of m .

NOTE. — Another method : If the line $y = mx + b$ touches the circle, its distance from the center $(0, 0)$ is equal to the radius.

$$\begin{aligned} & & \frac{b}{\pm\sqrt{1 + m^2}} &= r. \\ \therefore b &= \pm r\sqrt{1 + m^2}, \text{ as before.} \end{aligned}$$

66. If the equation to the circle be given in the form $x^2 + y^2 + 2Gx + 2Fy + C = 0$, we find, in the same way, the equation of the tangent in terms of its slope; *viz.*,

$$y + F = m(x + G) \pm \sqrt{G^2 + F^2 - C} \cdot \sqrt{1 + m^2}.$$

67. Length of the tangent from (x_1, y_1) to the circle $(x - h)^2 + (y - k)^2 = r^2$.

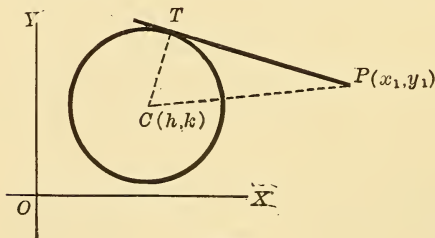

Fig. 85.

$$\begin{aligned} \overline{PT}^2 &= \overline{PC}^2 - r^2, \\ \overline{PC}^2 &= (x_1 - h)^2 \\ &\quad + (y_1 - k)^2, \\ \therefore \overline{PT}^2 &= (x_1 - h)^2 \\ &\quad + (y_1 - k)^2 - r^2. \end{aligned}$$

Hence, the square of the length of the

tangent is the result of substituting the co-ordinates of the given point in the sinister of the circle when the dexter is zero, *i. e.*, when the terms are transposed to one side.

If the equation be given in the form

$$x^2 + y^2 + 2Gx + 2Fy + C = 0,$$

we obtain
$$\overline{PC}^2 = (x_1 + G)^2 + (y_1 + F)^2,$$

$$\overline{CT}^2 = G^2 + F^2 - C.$$

$$\therefore \overline{PT}^2 = (x_1 + G)^2 + (y_1 + F)^2 - (G^2 + F^2 - C),$$

or,
$$\overline{PT}^2 = x_1^2 + y_1^2 + 2Gx_1 + 2Fy_1 + C,$$

which agrees with the rule given above.

68. Equation of tangent to the circle $x^2 + y^2 = r^2$ from a given external point (x_1, y_1) . — (Let x_2, y_2) be any other point on either tangent (since two may be drawn). Then the equation of the line joining the two points is,

$$x(y_1 - y_2) - y(x_1 - x_2) + x_1y_2 - y_1x_2 = 0.$$

The condition that this line should touch the circle is that its distance from the center be equal to the radius.

$$\therefore \frac{x_1y_2 - y_1x_2}{\pm \sqrt{(y_1 - y_2)^2 + (x_1 - x_2)^2}} = r.$$

Now, writing x, y , instead of x_2, y_2 , we get the required equation, *viz.*,

$$r^2 \{ (x - x_1)^2 + (y - y_1)^2 \} = \{ xy_1 - x_1y \}^2.*$$

Another method: In practice, it will be found more expedient to work thus:

Let $xx_2 + yy_2 = r^2$ be the tangent at the point of contact (x_2, y_2) whose co-ordinates are undetermined. Then, since it passes through (x_1, y_1) , we have,

* For another method see the appendix.

$$x_1x_2 + y_1y_2 = r^2 \quad \dots \dots \dots (1)$$

and

$$x_2^2 + y_2^2 = r^2 \quad \dots \dots \dots (2)$$

since (x_2, y_2) is on \odot .

From (1) and (2) we get values for x_2, y_2 , and substitute in the first equation taken.

EXERCISES.

1. If $x^2 + xy + y^2 + 2x + 3y = 0$ represents a circle, show that the axes make an angle $\phi = 60^\circ$. Also center is $(-\frac{1}{3}, -\frac{4}{3})$, and radius = $\frac{1}{3}\sqrt{21}$.

2. Find equations of tangent and normal to $x^2 + y^2 = 25$ at the point $(3, -4)$.
Ans. $3x - 4y = 25, 4x + 3y = 0$.

3. Find the circle whose center is $(1, -2)$, radius 5, the axes making angle $\phi = 120^\circ$.
Ans. $x^2 - xy + y^2 - 4x + 5y - 18 = 0$.

4. Find the tangent at the origin to the circle $x^2 + y^2 + hx + ky = 0$.
Ans. $hx + ky = 0$.

5. Find the tangent at $(4, 5)$ to the circle $x^2 + y^2 - 6x + 8y - 12 = 0$.

6. Find the tangent at the origin to the circle $x^2 + y^2 + 2x + 3y = 0$.
Ans. $2x + 3y = 0$.

7. Find the tangents to $x^2 + y^2 = 4$ which are inclined to the x -axis at (1) 45° , (2) 30° , (3) 60° , (4) 120° , (5) 150° .

8. Find the tangents to $x^2 + y^2 = 36$ which are inclined to the x -axis at 60° .
Ans. $y = x\sqrt{3} + 12, y = x\sqrt{3} - 12$.
 Also, those at 45° .
Ans. $x - y \pm \sqrt{2} = 0$.

9. The axes making an angle ϕ , find the equation of the circle through the origin making intercepts a, b , on the axes.
Ans. $x^2 + 2xy \cos \phi + y^2 = ax + by$.

10. Find the point of contact of the line $x + y = 2 + \sqrt{2}$ which touches the circle $x^2 + y^2 - 2x - 2y + 1 = 0$.
Ans. $(1 + \frac{1}{2}\sqrt{2}, 1 + \frac{1}{2}\sqrt{2})$.

11. Find the length of the tangent from $(3, 4)$ to $x^2 + y^2 - 22x + 16y + 4 = 0$.

12. Find the length of the tangent from $(1, -2)$ to $3x^2 + 3y^2 - x - 4 = 0$.
Ans. $\sqrt{\frac{10}{3}}$.

13. Find the locus of a point such that if tangents be drawn from it to two concentric circles, their lengths may have the ratio $k : 1$; also $m : n$.

14. Find the length of tangent from the origin to $x^2 + y^2 - 4x - y + 2 = 0$.

15. Find the condition that $\frac{x}{a} + \frac{y}{b} = 1$ may touch the circle $x^2 + y^2 = r^2$.

Ans. $a^2b^2 = r^2(a^2 + b^2)$.

16. Find the equation of the tangent from (6, 8) to the circle $x^2 + y^2 = 25$.

Take $y = mx \pm r\sqrt{1 + m^2}$.

Then x, y, r , are known. Solve for m , etc.

Find the equation of the tangent to the circle.

17. $x^2 + y^2 = 25$, whose slope is 2.

18. $x^2 + y^2 = 9$, whose slope is $\frac{1}{2}$.

19. $x^2 + y^2 = 4$, which is \parallel to $y - 2x - 1 = 0$.

20. $x^2 + y^2 = 1$, which is \perp to $2x - y + 2 = 0$, also which makes 60° with x -axis.

21. $x^2 + y^2 - 2x - 2y + 1 = 0$ and \perp to $2x + 3y + 4 = 0$.

22. $x^2 + y^2 - 8x - 6y + 12 = 0$ and \parallel to $2x - 5y - 9 = 0$.

23. Find the equation of the tangent to $x^2 + y^2 = 2rx$ at (x_1, y_1) .

24. Find the length of the tangent from (8, 10) to the circle $x^2 + y^2 - 3x = 0$.

Ans. $2\sqrt{35}$.

25. Find the equations of the tangents to the circle $x^2 + y^2 - 4x - 2y + 1 = 0$ which are \parallel to the x -axis. Also those drawn to it from the origin.

Ans. $y = -1, y = 3, x = 0, 3x + 4y = 0$.

69. Equation of the chord of contact for the point (x_1, y_1) .*

— Let $(x_2, y_2), (x_3, y_3)$, be the points of contact of the tangents.

Then these tangents are

$$xx_2 + yy_2 = r^2. \quad \dots \dots \dots (1)$$

$$xx_3 + yy_3 = r^2. \quad \dots \dots \dots (2)$$

But (x_1, y_1) lies on each tangent; hence,

$$x_1x_2 + y_1y_2 = r^2 \quad \dots \dots \dots (3)$$

$$x_1x_3 + y_1y_3 = r^2 \quad \dots \dots \dots (4)$$

* DEFINITION. — The chord of contact of any point with respect to a given circle is the line joining the points of contact of the tangents drawn to the circle from that point.

From equations (4) and (5) it is seen that the co-ordinates of both the points (x_2, y_2) , (x_3, y_3) , satisfy the equation

$$xx_1 + yy_1 = r^2 \dots \dots \dots (5)$$

Hence this is the required equation, that of the chord of contact.

If the circle is

$$x^2 + y^2 + 2Gx + 2Fy + C = 0,$$

by similar reasoning its chord of contact is found to be

$$xx_1 + yy_1 + G(x + x_1) + F(y + y_1) + C = 0.$$

SPECIAL CASE. — If (x_1, y_1) is on the circle, equation (5) represents a tangent at that point. Hence the chord of contact of a point on the circle coincides with the tangent at that point.

70. Poles and Polars. — **DEF.** If a chord of a circle turns about a fixed point in its plane, the locus of the point of intersection of the two tangents drawn at the extremities of the chord is called the **polar** of the given point.

The fixed point is called the **pole** of that locus (with respect to the circle). These definitions for pole and polar are the same for the other curves which we shall study.*

71. To find the polar of the point (x_1, y_1) with respect to the circle $x^2 + y^2 = r^2$. — Let (x_2, y_2) be the point of intersection of the two tangents. We must now find the locus of the point (x_2, y_2) .

The chord of contact of this point is

$$xx_2 + yy_2 = r^2 \dots \dots \dots (1)$$

But, by definition, it passes through the fixed point (x_1, y_1) ,

$$\therefore x_1x_2 + y_1y_2 = r^2 \dots \dots \dots (2)$$

* The teacher should explain these conceptions, using illustrations.

Equation (2) shows that the co-ordinates of (x_2, y_2) always satisfy the equation

$$xx_1 + yy_1 = r^2 \dots \dots \dots (3)$$

which must therefore be the locus of (x_2, y_2) , *i.e.*, the polar of the point (x_1, y_1) .

The polar is evidently a straight line.

SPECIAL CASES. (1) If (x_1, y_1) is on the circle, equation (3) is also a tangent. Hence the polar and tangent of a given point on the circle are identical.

(2) If (x_1, y_1) is an external point, (3) represents its chord of contact; hence the polar and chord of contact of an external point are identical.

72. Theorem. — If the polar of P_1 passes through P_2 , then the polar of P_2 passes through P_1 .

Let P_1 be (x_1, y_1) , $P_2(x_2, y_2)$.

Then the polars of these points are

$$xx_1 + yy_1 = r^2 \dots \dots \dots (1)$$

$$xx_2 + yy_2 = r^2 \dots \dots \dots (2)$$

Now, if (1) passes through P_2 , we have

$$x_2x_1 + y_2y_1 = r^2 \dots \dots \dots (3)$$

and if (2) passes through P_1 , we have

$$x_1x_2 + y_1y_2 = r^2 \dots \dots \dots (4)$$

But (3) and (4) are identical; hence, etc.

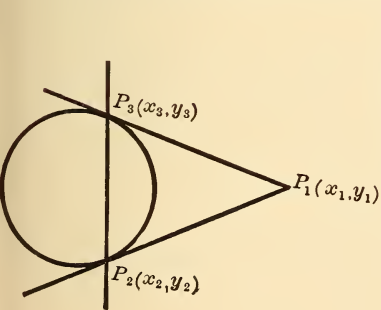

Fig. 86.

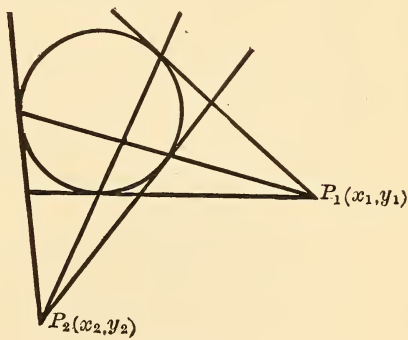

Fig. 87.

73. Theorem. If the polars of P_1 and P_2 intersect in P , then P is the pole of the line $P_1 P_2$.

Proof: The polar of P_1 passes through P ,

\therefore the polar of P passes through P_1 . [§72.]

Similarly, the polar of P passes through P_2 .

$\therefore P_1 P_2$ is the polar of P , or P is the pole of $P_1 P_2$. *Q.E.D.*

74. To find the pole of the line $Ax + By + C = 0$ with respect to the circle $x^2 + y^2 = r^2$.

Let (x_1, y_1) be the pole required.

Then its polar is $xx_1 + yy_1 = r^2$.

Now if this equation and the given equation represent the same line, they must differ only by a constant factor, *i.e.*, the coefficients in both are proportional.

$$\therefore \frac{x_1}{A} = \frac{y_1}{B} = -\frac{r^2}{C}.$$

$$\therefore x_1 = -\frac{Ar^2}{C}, \quad y_1 = -\frac{Br^2}{C}.$$

These values are real if A, B, C , are real. Hence every real line has a pole.

NOTE. — By reasoning, similar to that employed in preceding articles, the chord of contact of the circle $x^2 + y^2 + 2Gx + 2Fy + C = 0$ is found to be, $xx_1 + yy_1 + G(x + x_1) + F(y + y_1) + C = 0$.

The polar of (x_1, y_1) is the same equation, and the previous remarks hold true here.

75. Geometrical construction of the polar and pole. — Let P be the given point whose polar is required. Take center O as origin, and OP as x -axis. Then the equation of the circle is $x^2 + y^2 = r^2$, and P is the point $(x_1, 0)$.

The polar of P is $xx_1 = r^2$, $\therefore x = \frac{r^2}{x_1}$, which is a line parallel to the y -axis and at a distance $\frac{r^2}{x_1}$ from it. Hence, to

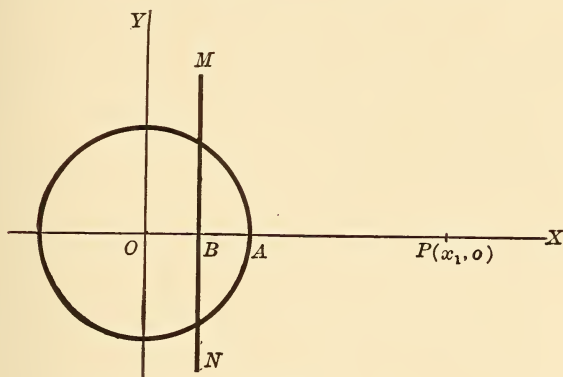

Fig. 88.

construct it, find B so that $OP \times OB = \overline{OA}^2$, i.e., a third proportional to OP and OA (r). Then $MN \perp$ to OP at B is the polar required.

To find the pole of a given line MN, draw $OB \perp$ to it, and determine P so that $OB \times OP = \overline{OA}^2 = r^2$.

EXERCISES.

1. Find the polars of $(1, 4)$, $(-2, -5)$, $(3, -1)$, $(0, 1)$, $(-1, -2)$, $(-4, 1)$, with respect to the circle $x^2 + y^2 = 49$.

2. Find the poles of $x - y + 1 = 0$, $3x + 4y - 6 = 0$,

$$\frac{x}{h} + \frac{y}{k} = 1, \quad y - 6x + 12 = 0, \quad 2y - 4x - 5 = 0,$$

with respect to the circle $x^2 + y^2 = 75$.

3. Find the pole of $x \cos \alpha + y \sin \alpha = p$ with respect to the circle $x^2 + y^2 = 20$.

$$\text{Ans. } \frac{20 \cos \alpha}{p}, \quad \frac{20 \sin \alpha}{p}.$$

4. Show that the nine-points' circle of the Δ whose vertices are $(2a, \frac{2}{a})$, $(2b, \frac{2}{b})$, $(2c, \frac{2}{c})$, passes through the origin.

5. Prove that the distances of two points from the center of a circle are proportional to the distances of each from the polar of the other.

6. Find the condition that the polar of (h, k) with respect to the circle $x^2 + y^2 = 9$ may touch the circle $x^2 + y^2 = 6y$. *Ans.* $h^2 + 6k = 9$.

7. If the polars of the vertices of a ΔABC form a $\Delta A'B'C'$, prove AA' , BB' , CC' , are concurrent.

NOTE. — The polars of the vertices of $A'B'C'$ are the sides of ABC .

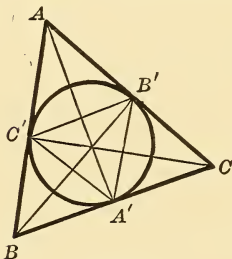

Fig. 89.

8. If a circle is inscribed in a Δ , show that the lines drawn from the vertices to the opposite points of contact are concurrent.

SUGGESTION. — ΔABC and $A'B'C'$ bear the same relation to each other as those in Ex. 7.

9. Find the condition that the polar of (h, k) with respect to $x^2 + y^2 = a^2$ may touch $(x - \alpha)^2 + (y - \beta)^2 = r^2$.

Ans. $(ah + \beta k - a^2)^2 = r^2 (h^2 + k^2)$.

10. If a circle is inscribed in a quadrilateral, show that the diagonals and the lines joining the opposite points of contact are all concurrent.

11. Find the polar of $(-9, -7)$ with respect to $x^2 + y^2 = 14$.

12. Find the polar of $(-1, -2)$ with respect to $x^2 + y^2 = 3$.

13. Find the pole of $2x + 6y + 14 = 0$ with respect to the circle $x^2 + y^2 = 5$.

14. Pole of $x - y - 2 = 0$ with respect to $x^2 + y^2 = 8$.

15. Pole of $ax + by - 1 = 0$ with respect to $x^2 + y^2 = 49$.

Ans. $(49a, 49b)$.

16. Find the points of contact of the tangents from $(4, 7)$ to the circle $x^2 + y^2 = 64$.

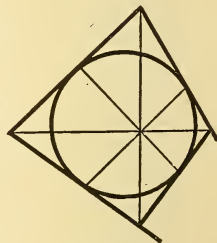

Fig. 90.

17. Show analytically that the angle inscribed in a semicircle is a right angle.

18. Under what conditions will the circle $Ax^2 + Ay^2 + Dx + Ey + F = 0$ touch the axes? *Ans.* $D^2 = 4AF, E^2 = 4AF.$

19. Find the condition that the circles

$$\left. \begin{aligned} x^2 + y^2 + 2G_1x + 2F_1y = 0, \\ x^2 + y^2 + 2G_2x + 2F_2y = 0, \end{aligned} \right\} \begin{array}{l} \text{may touch each other} \\ \text{at the origin.} \end{array}$$

$$\text{Ans. } \frac{G_1}{F_1} = \frac{G_2}{F_2}.$$

76. **The radical axis of two circles.***—Let the two circles be

$$x^2 + y^2 + 2Gx + 2Fy + C = 0 \quad \dots (1)$$

and $x^2 + y^2 + 2G_1x + 2F_1y + C_1 = 0 \quad \dots (2)$

Then the equation

$$x^2 + y^2 + 2Gx + 2Fy + C = x^2 + y^2 + 2G_1x + 2F_1y + C_1 \quad (3)$$

passes through the points of intersection, real or imaginary, of (1) and (2) [why?], and represents a straight line, since its equation reduces to

$$2(G - G_1)x + 2(F - F_1)y + C - C_1 = 0 \quad \dots (4)$$

*NOTE 1.—One of the circles may be a “point-circle.” Thus the radical axis of

$$(x - h)^2 + (y - k)^2 - r^2 = 0 \quad \dots (1)$$

and $(x - h_1)^2 + (y - k_1)^2 = 0 \quad \dots (2)$

is the line

$$2(h_1 - h)x + 2(k_1 - k)y + h^2 + k^2 - h_1^2 - k_1^2 - r^2 = 0 \quad (3)$$

It is the locus of a point which moves so that its distance from a given point (h_1, k_1) is always equal to the tangent drawn from it (the moving point) to the circle (1).

NOTE 2.—The equation $S_1 - S_2 = 0$ [§ 76] shows that the square of the length of the tangent from (x, y) to $S_1 = 0$ is equal to the square of the tangent from (x, y) to $S_2 = 0$.

Hence, the radical axis of two circles is the locus of a point from which tangents drawn to the two circles are equal.

It is called the **radical axis** of the two circles.

For brevity, if the \odot be $S_1 = 0$, $S_2 = 0$, the $S_1 - S_2 = 0$ represents their radical axis.

77. The line of centers of two circles is perpendicular to their radical axis. Its equation may be written,

$$\begin{vmatrix} x & y & 1 \\ -G & -F & 1 \\ -G_1 & -F_1 & 1 \end{vmatrix} = 0,$$

or $x(F_1 - F) - y(G_1 - G) + GF_1 - FG_1 = 0$.

This is evidently \perp to the radical axis, equation (4), §76.

78. Common tangent of two circles.— If two circles are tangent to each other, their radical axis is their common tangent at the point of contact.

EXAMPLE.— Determine λ so that the circles

$$x^2 + y^2 - 6x - 4y + \lambda = 0 \quad \dots \quad (1)$$

$$x^2 + y^2 + 4x - 3y + \lambda = 0 \quad \dots \quad (2)$$

may touch each other.

SUGGESTION.— Find radical axis by subtraction, then determine λ so that the radical axis may intersect either \odot in two coincident points.

79. Radical center of three circles.— Let $S = 0$, $S_1 = 0$, $S_2 = 0$, be three circles. Then the radical axes of these circles taken in pairs are

$$S - S_1 = 0, \quad S - S_2 = 0, \quad S_1 - S_2 = 0.$$

Now, any values of x and y which satisfy any two of these equations, evidently satisfy the third. Hence the radical axes of three circles taken in pairs are concurrent in a point, called the **radical center** of the three circles.

NOTE.— Tangents drawn from the radical center to the three circles are all equal.

80. Coaxial Circles. — The equation $S - \lambda S_1 = 0$, represents a circle passing through the points of intersection of the $\odot S = 0$ and $S_1 = 0$. It may represent any one of a system of circles according as we assign different values to the variable parameter λ . Such a system passing through two fixed points (which may be real or imaginary) is called a **coaxial system**. The line joining these two points is the common radical axis of any two circles of the system.

NOTE 1. — $S - \lambda S_1 = 0$ shows that the tangents to the two circles $S = 0$, $S_1 = 0$ from any point, are in a constant ratio $\lambda : 1$. Hence, if a point moves so that the tangents drawn from it to two given circles are in a constant ratio, its locus is a coaxial circle.

NOTE 2. — If $S = 0$ be one circle of a coaxial system whose radical axis is $Ax + By + C = 0$, then any other circle of the system may be represented by the equation $S + k(Ax + By + C) = 0$ where k is some absolute constant. For the radical axis of the two circles is $S - \{S + k(Ax + By + C)\} = 0$, or $Ax + By + C = 0$, the given radical axis. Hence . . . , etc.

81. To represent a coaxial system, having given two fixed points A and B and the distance $2c$ between them. — Take AB as y -axis, and O, its mid-point, as origin.

Then the x -axis, or the line $x = 0$, will be the common radical axis of the system. Also, $x^2 + y^2 - c^2 = 0$ represents one of the circles, — the circle whose center is the origin.

∴ by note 2, § 80, the equation

$$x^2 + y^2 - c^2 + 2kx = 0 \quad (1)$$

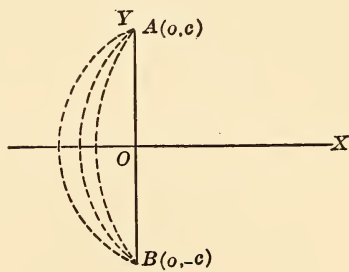

Fig. 91.

represents any circle of the system where c^2 is constant for all the circles while k is a number which varies for each circle.

NOTE. — It is evident that the centers of the system will lie on the axis of x . The system may \therefore be represented also by the equation $(x - \lambda)^2 + y^2 = c^2$ where λ varies with each circle and is the distance of its center from the origin.

The equation (1) above may be written in the form

$$(x + k)^2 + y^2 = k^2 + c^2.$$

Now, if $k^2 + c^2 = 0$, this becomes a "point-circle."

$$\therefore k = \pm c \sqrt{-1}.$$

\therefore the circle becomes one of the points $(\pm c \sqrt{-1}, 0)$. These points are called the **limiting points** of the system. If the \odot intersect in real points, c is real, and the limiting points are therefore imaginary; but if the circles intersect in imaginary points $\pm a \sqrt{-1}$, then there are two real limiting points $(\pm a, 0)$.*

82. The angle of intersection between two circles. — This is the angle between the tangents, one to each circle, at their point of intersection.

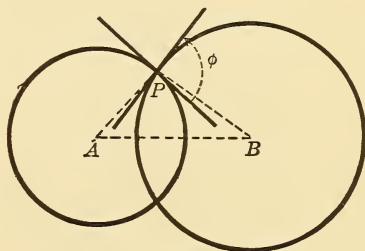

Fig. 92.

Tangents at P, the point of intersection of the two circles, are \perp to the radii AP and BP. Hence the angle between the tangents is equal to angle APB.

$$\begin{aligned} \text{Let } AB &= \delta, \\ AP &= r_1, \\ BP &= r_2. \end{aligned}$$

$$\text{Then } \delta^2 = r_1^2 + r_2^2 - 2 r_1 r_2 \cos \phi.$$

$$\therefore \cos \phi = \frac{r_1^2 + r_2^2 - \delta^2}{2 r_1 r_2}.$$

* See note 7, appendix.

If the \odot be given,

$$x^2 + y^2 + 2 G_1 x + 2 F_1 y + C_1 = 0 \quad \dots \quad (1)$$

and $x^2 + y^2 + 2 G_2 x + 2 F_2 y + C_2 = 0 \quad \dots \quad (2)$

Then $r_1^2 = G_1^2 + F_1^2 - C_1, \quad r_2^2 = G_2^2 + F_2^2 - C_2,$

$$\therefore \delta^2 = (G_1 - G_2)^2 + (F_1 - F_2)^2.$$

$$\therefore 2 r_1 r_2 \cos \phi = 2 G_1 G_2 + 2 F_1 F_2 - C_1 - C_2.$$

NOTE. — The condition that the two circles cut orthogonally is

$$2 G_1 G_2 + 2 F_1 F_2 - C_1 - C_2 = 0.$$

83. To find the circle which cuts orthogonally the three given circles.

$$x^2 + y^2 + 2 G_1 x + 2 F_1 y + C_1 = 0$$

$$x^2 + y^2 + 2 G_2 x + 2 F_2 y + C_2 = 0$$

$$x^2 + y^2 + 2 G_3 x + 2 F_3 y + C_3 = 0$$

Let the required circle be

$$x^2 + y^2 + 2 Gx + 2 Fy + C = 0 \quad \dots \quad (1)$$

Then $2 GG_1 + 2 FF_1 - C - C_1 = 0 \quad \dots \quad (2)$

$$2 GG_2 + 2 FF_2 - C - C_2 = 0 \quad \dots \quad (3)$$

$$2 GG_3 + 2 FF_3 - C - C_3 = 0 \quad \dots \quad (4)$$

Eliminating $G, F,$ and C from (1), (2), and (3), and (4) we get,

$$\begin{vmatrix} x^2 + y^2 & x & y & 1 \\ -C_1 & G_1 & F_1 & -1 \\ -C_2 & G_2 & F_2 & -1 \\ -C_3 & G_3 & F_3 & -1 \end{vmatrix} = 0,$$

which is the required equation of the circle cutting the three given circles at right angles.*

* See notes 5 and 6, appendix.

DIAMETERS.

84. Definition. — The diameter of a curve is the locus of the mid-points of a system of parallel chords.

85. To find the equation of a diameter of the circle $x^2 + y^2 = r^2$. — Let any one of a system of parallel chords be $y = mx + b$.

Also let it meet the circle in the points (x_1, y_1) , (x_2, y_2) .

$$\text{Then} \quad m = -\frac{x_1 + x_2}{y_1 + y_2}. \quad \left[\text{See § 19, (1).} \right]$$

Also, if (x, y) are the co-ordinates of its middle point, we have,

$$2x = x_1 + x_2,$$

$$2y = y_1 + y_2.$$

$$\therefore m = -\frac{x}{y},$$

or

$$y = -\frac{1}{m}x$$

is the required equation of the diameter.

DISCUSSION. — This equation shows that the diameter passes through the center of the circle and is perpendicular to its chords.

EXERCISES.

1. Find the equation of the circle, center on y -axis, and passing through $(0, 0)$ and (x_1, y_1) . *Ans.* $y_1(x^2 + y^2) = y(x_1^2 + y_1^2)$.

2. Find equation of the circle which passes through (a, b) and touches the line $\frac{x}{a} + \frac{y}{b} = 1$ at the point $(3a, -2b)$.

3. A secant to the circle $x^2 + y^2 = r^2$ is drawn through the fixed point (x_1, y_1) . Find the locus of the mid-point of the chord.

$$\text{Ans. } x^2 + y^2 - x_1x - y_1y = 0.$$

4. Find the length of the common chord of the \odot s.

$$\left. \begin{aligned} (x-a)^2 + (y-b)^2 &= r^2, \\ (x-b)^2 + (y-a)^2 &= r^2. \end{aligned} \right\} \text{Ans. } \sqrt{4r^2 - 2(a-b)^2}.$$

Find the condition that these circles touch.

SUGGESTION. — Put the result = 0.

5. For what point on the circle $x^2 + y^2 = 4$ is the subtangent equal to the subnormal? Also for what point has the tangent a slope = 1?

6. Through a fixed point (x_1, y_1) on the circle $x^2 + y^2 = r^2$ a chord is drawn. Find locus of its mid-point.

$$\text{Ans. } (x - \frac{1}{2}x_1)^2 + (y - \frac{1}{2}y_1)^2 = (\frac{1}{2}r)^2.$$

7. $x^2 + y^2 = r_1^2$, $x^2 + y^2 = r_2^2$, are two concentric circles. Find the locus of a point from which tangents to the circles are inversely proportional to the radii.

$$\text{Ans. } x^2 + y^2 = r_1^2 + r_2^2.$$

8. A chord of the circle $x^2 + y^2 = 49$ is parallel to the line $x - y = 0$, and is 6 units long. Find its equation.

SUGGESTION. — Take $x - y + k = 0$. Find points of intersection with circle. Then express that chord = 6. Find k .

9. Find radical center of circles

$$\left. \begin{aligned} x^2 + y^2 + 5y - 1 &= 0, \\ x^2 + y^2 + 2x + 2y - 1 &= 0, \\ x^2 + y^2 + 3x &= 0. \end{aligned} \right\} \text{Ans. } (3, 2).$$

10. Find radical axis of the circles

$$\left. \begin{aligned} x^2 + y^2 - 8x - 6y + 12 &= 0, \\ x^2 + y^2 + 4x - 9y + 5 &= 0. \end{aligned} \right\} \text{Ans. } 3y - 12x = -7.$$

11. Radical axis of

$$\left. \begin{aligned} x^2 + y^2 - 2x + 3y &= 1, \\ x^2 + y^2 + 4x - 5y &= 5. \end{aligned} \right\}$$

12. Radical center of

$$\left. \begin{aligned} x^2 + y^2 - 6x + 2 &= 0, \\ x^2 + y^2 + 4y + 1 &= 0, \\ x^2 + y^2 - 5x - 9y + 15 &= 0. \end{aligned} \right\}$$

13. Show that the circles

$$\left. \begin{aligned} x^2 + y^2 + 14x + 5y - 7 &= 0, \\ x^2 + y^2 + 4x + y - 3 &= 0, \\ x^2 + y^2 - x - y - 1 &= 0, \end{aligned} \right\} \text{are coaxial.}$$

14. Find the length of the common chord of the circles

$$\begin{aligned}x^2 + y^2 - 5x - 12y + 3 &= 0, \\x^2 + y^2 + 4x - 9y + 6 &= 0.\end{aligned}$$

15. Find the circle through $(5, -9)$ and the points of intersection of the circles

$$\begin{aligned}x^2 + y^2 - 2x - 2y + 1 &= 0, \\x^2 + y^2 + 8x - 6y + 4 &= 0.\end{aligned}$$

16. Find the circle through the origin and the points of intersection of

$$\begin{aligned}x^2 + y^2 - 8x &= 0, \\x^2 + y^2 + 4y - x - 2 &= 0.\end{aligned}$$

17. Find locus of a point such that tangents from it to the circles

$$\left. \begin{aligned}x^2 + y^2 + 4y &= 0, \\x^2 + y^2 &= 9,\end{aligned} \right\} \text{ are in ratio } 4 : 7.$$

18. Find the circle through the origin and the points of intersection of

$$\begin{aligned}x^2 + y^2 + 4x - 9y - 8 &= 0, \\3x + 4y + 2 &= 0.\end{aligned}$$

19. Find the circle whose diameter is the common chord of the circles

$$\begin{aligned}x^2 + y^2 - 23x + 11y &= 0, \\x^2 + y^2 - 12x + 11 &= 0.\end{aligned}$$

$$\text{Ans. } x^2 + y^2 - 5x - 7y + 18 = 0.$$

86. **Centers of Similitude.**—The line of centers $O'O$ of two circles is divided harmonically* at A and B in the ratio of

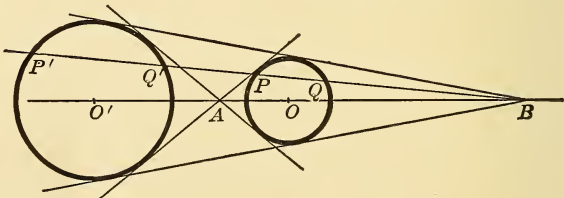

Fig. 93.

their radii; the points A and B are called the **internal** and **external** centers of similitude, respectively. Several properties

* Harmonically means internally and externally in the same ratio.

of these points are proven by elementary geometry, which the student can readily show analytically; viz.,

(α) The external common tangents of the circles pass through B; the internal tangents through A.

(β) Any line passing through either center of similitude is cut similarly by the two circles, thus:

$$BP : BP' :: BQ : BQ' :: r : r'.$$

(γ) The six centers of similitude of three circles, taken in pairs, lie on four straight lines called the axes of similitude.

87. Common Tangents to Two Circles.—To find the tangent to two circles, we must ascertain,

- (1) The centers of the circles.
- (2) A center of similitude (x_1, y_1) .
- (3) For what value of m , $y - y_1 = m(x - x_1)$ will touch either one of the circles.

EXAMPLE 1. Given the circles,

$$x^2 + y^2 - 10x + 12y + 25 = 0 \quad \dots \dots \dots (1)$$

and $x^2 + y^2 + 8x = 0 \quad \dots \dots \dots (2)$

The centers are $(5, -6)$, $(-4, 0)$, radii are 6 and 4; their ratio is $\frac{3}{2}$. Hence, the internal center of similitude is,

$$x_1 = \frac{3(-4) + 2(5)}{3 + 2}, \quad y_1 = \frac{3 \cdot 0 + 2(-6)}{3 + 2},$$

and the external center is,

$$x_2 = \frac{3(-4) - 2(5)}{3 - 2}, \quad y_2 = \frac{3 \cdot 0 - 2(-6)}{3 - 2}.$$

\therefore the external center is $(-22, 12)$.

$\therefore y - 12 = m(x + 22)$ is the equation of any line through that center.

This will touch the first circle if its distance from the center $(5, -6)$ is equal to its radius 6.

$$\therefore \frac{-18 - 27m}{\pm\sqrt{1 + m^2}} = 6, \text{ whence } m \text{ may be found.}$$

Ex. 2. Find the common external tangent to the circles

$$x^2 + y^2 = 16 \dots \dots \dots (1)$$

$$x^2 + y^2 + 6x - 8y = 0 \dots \dots \dots (2)$$

The line $y = mx \pm 4\sqrt{1+m^2}$ is a tangent to (1) for all values of m . Now treat this equation and (2) as simultaneous, and determine m so that they may intersect in two coincident points.

EXERCISES.

1. Find the external common tangents to the circles

$$x^2 + y^2 - 4x + 6y - 9 = 0.$$

$$x^2 + y^2 - 6x + 10y + 4 = 0.$$

2. Find the internal common tangents to the circles

$$x^2 + y^2 - 9y - 15 = 0,$$

$$x^2 + y^2 + 6x - 3y = 0.$$

3. Find the external and internal common tangents to the circles

$$x^2 + y^2 - 8x + 6y - 14 = 0,$$

$$x^2 + y^2 - 2x - 2y + 1 = 0.$$

4. Show that the tangents from the origin to the circle

$$(x - a)^2 + (y - b)^2 = r^2$$

Also touch the circle

$$(x - ka)^2 + (y - kb)^2 = (kr)^2.$$

5. Find the circle through the origin and the points of intersection of the circles

$$x^2 + y^2 + 2G_1x + 2F_1y + C_1 = 0,$$

$$x^2 + y^2 + 2G_2x + 2F_2y + C_2 = 0.$$

$$\text{Ans. } (C_2 - C_1)(x^2 + y^2) + 2(G_1C_2 - G_2C_1)x + 2(F_1C_2 - F_2C_1)y = 0.$$

6. A point moves so that the square of its distance from the base of an isosceles Δ = product of its distances from sides. Find its locus.

Let vertices be $(-a, 0)$, $(a, 0)$, $(0, b)$.

$$\text{Ans. } b(x^2 + y^2) + 2a^2y - ba^2 = 0$$

88. Polar Equations of the Circle. — Let O be the pole, ON the polar axis.

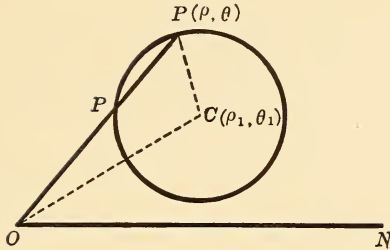

Fig. 94.

P is any point on the circle, and C is the center.

Now, in $\triangle OPC$,

$$\overline{CP}^2 = \overline{OP}^2 + \overline{OC}^2 - 2 OP \cdot OC \cos \text{POC}.$$

$$\therefore \rho^2 - 2\rho\rho_1 \cos(\theta - \theta_1) + \rho_1^2 - r^2 = 0 \dots (1)$$

This is the most general equation of the \odot in polar coordinates.

SPECIAL CASES. (1) If ON coincide with OC, then $\theta_1 = 0$.

$$\therefore \rho^2 - 2\rho\rho_1 \cos \theta + \rho_1^2 - r^2 = 0 \dots (2)$$

(2) If the pole is on the circle, $\rho_1 = r$.

$$\therefore \rho - 2r \cos(\theta - \theta_1) = 0 \dots (3)$$

(3) If pole is on the circle, and polar axis passes through the center,

$$\rho_1 = r, \quad \theta_1 = 0.$$

$$\therefore \rho - 2r \cos \theta = 0 \dots (4)$$

(4) If center is at pole, $\rho_1 = 0$.

\therefore By equation (1) above, we get,

$$\rho = r \dots (5)$$

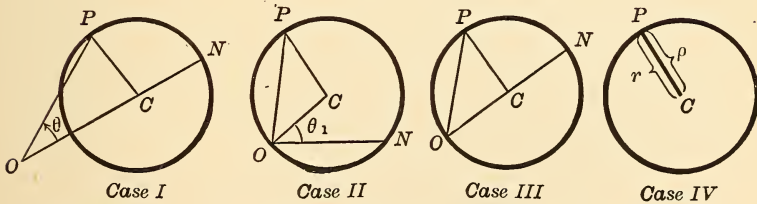

Fig. 95.

Fig. 96.

Fig. 97.

Fig. 98.

The Special Cases.

EXERCISES.

1. The diameter of the \odot through (o, o) , (ρ_1, θ_1) , (ρ_2, θ_2) ,
is $\sqrt{\rho_1^2 + \rho_2^2 - 2\rho_1\rho_2 \cos(\theta_1 - \theta_2)} \div \sin(\theta_1 - \theta_2)$.

2. The condition that the line

$$\rho = \frac{1}{a \cos \theta + b \sin \theta}$$

may touch the circle $\rho = 2a \cos \theta$

is $a^2b^2 + 2ab - 1 = 0$.

3. The tangents from the origin to the circle $(x - a)^2 + (y - b)^2 = r^2$
are $(bx - ay)^2 = r^2(x^2 + y^2)$.

4. If AB is the diameter of a circle, the polar of A with respect to
any circle which cuts the first orthogonally, passes through B.

5. One vertex of a rectangle is fixed (h, k) , two others move on the
circle $x^2 + y^2 = r^2$. Show that the fourth moves on the circle

$$x^2 + y^2 + h^2 + k^2 - 2r^2 = 0.$$

6. The locus of the center of a circle which cuts two fixed circles at
right angles is their radical axis.

7. The centers of three \odot s are A, B, C, and radii R_1, R_2, R_3 . Show
that the circles are coaxial if

$$BC \cdot R_1^2 + CA \cdot R_2^2 + AB \cdot R_3^2 + BC \cdot AB \cdot CA = 0.$$

8. The common tangents to the circles

$$x^2 + y^2 - 2ax = 0,$$

$$x^2 + y^2 - 2by = 0,$$

are represented by the equation

$$2ab(x^2 + y^2 - 2ax) = \{ab - ax + by\}^2.$$

NOTE. — The equation $\rho^2 - 2\rho\rho_1 \cos(\theta - \theta_1) + \rho_1^2 - r^2 = 0$ is a
quadratic in ρ . Thus, for each value of θ , there are two values of ρ ;
viz., OP and OP_1 .

The product of the roots is $\rho_1^2 - r^2$,

$$\begin{aligned} \text{i.e.,} \quad OP \cdot OP_1 &= \overline{OC}^2 - \overline{CP}^2 \\ &= (OC - CP)(OC + CP), \end{aligned}$$

which agrees with a well-known theorem in elementary geometry.

89. Polar Equation of the Circle $x^2 + y^2 + 2Gx + 2Fy + C = 0$.

Take the origin for the pole.

$$\therefore x = \rho \cos \theta, \quad y = \rho \sin \theta.$$

These give $\rho^2 + 2\rho(G \cos \theta + F \sin \theta) + C = 0$ for the required equation.

If the pole is on the circle, *i.e.*, the circle passes through the origin, then $C = 0$, and the equation becomes

$$\rho + 2(G \cos \theta + F \sin \theta) = 0.$$

EXERCISES ON CHAPTER V.

1. Given the base whose extremities are (x_1, y_1) , (x_2, y_2) , and the vertical angle ψ of a Δ , find the locus of the vertex.

$$\text{Ans. } (x - x_1)(x - x_2) + (y - y_1)(y - y_2) = \pm \text{ctn } \psi \begin{vmatrix} x & y & 1 \\ x_1 & y_1 & 1 \\ x_2 & y_2 & 1 \end{vmatrix}$$

2. The centers of three circles are (a_1, b_1) , (a_2, b_2) , (a_3, b_3) , and their radii are r_1, r_2, r_3 . If these circles are taken in pairs, show that the three external centers of similitude lie on the line whose equation is

$$\begin{vmatrix} r_1 & r_2 & r_3 \\ b_1 & b_2 & b_3 \\ 1 & 1 & 1 \end{vmatrix} x - \begin{vmatrix} r_1 & r_2 & r_3 \\ a_1 & a_2 & a_3 \\ 1 & 1 & 1 \end{vmatrix} y = \begin{vmatrix} r_1 & r_2 & r_3 \\ b_1 & b_2 & b_3 \\ a_1 & a_2 & a_3 \end{vmatrix}$$

3. A, B, C, etc., are given points. Find locus of P such that

$$\overline{PA}^2 + \overline{PB}^2 + \overline{PC}^2 +, \text{ etc.}, = \text{a constant.}$$

Also, $m_1 \overline{PA}^2 + m_2 \overline{PB}^2 + m_3 \overline{PC}^2 +, \text{ etc.}, = \text{a constant.}$

Ans. Circles.

4. $(a, 0)$, $(-a, 0)$, are the ends of base of a Δ , ψ the vertical angle. Show that the locus of the orthocenter is

$$x^2 + y^2 + 2ay \text{ctn } \psi - a^2 = 0.$$

5. Two tangents from (h, k) and their chord of contact to the circle $x^2 + y^2 = a^2$ form a Δ . Show that its area is $\frac{\{a^2(h^2 + k^2 - a^2)\}^{\frac{3}{2}}}{h^2 + k^2}$.

6. Circles are described on the three diagonals of a complete quadrilateral as diameters. Show that they have, two by two, the same radical axis.

7. Given four points A, B, C, D and four circles are described through the points taken in groups of three, viz., ABC, ABD, ACD, BCD. Show that any two of them intersect at the same angle as the remaining two.

8. Given four straight lines, which intersect, and taken, three at a time, form four triangles. Show that their orthocenters are collinear.

9. The circle whose diameter is the distance between (ρ_1, θ_1) and (ρ_2, θ_2) is

$$\rho^2 = \rho_1 \rho \cos(\theta - \theta_1) + \rho_2 \rho \cos(\theta - \theta_2) - \rho_1 \rho_2 \cos(\theta_1 - \theta_2).$$

NOTE. — Let A and B be the given points, P (ρ, θ) any point on the circle.

$$\therefore \overline{PA}^2 + \overline{PB}^2 = \overline{AB}^2, \text{ etc.}$$

10. The locus of a point whose polar with respect to $x^2 + y^2 = a^2$ touches $(x - h)^2 + (y - k)^2 = r^2$, is

$$(hx + ky - a^2)^2 = r^2 (x^2 + y^2).$$

11. Two points, A and B, are on rectangular axes, origin O, so that $OA = OB = a$. Find the locus of a point P so that $\angle OPA = \angle OPB$.

$$\text{Ans. } (x - y)(x^2 + y^2 - ax - ay) = 0.$$

What does this last equation represent?

12. A, B, C, are three points on a circle, O any other point on it. From O \perp s are dropped on the sides of $\triangle ABC$. Show that their feet are collinear.

NOTE. — Use polar co-ordinates, O as pole, and equation of \odot $\rho = 2a \cos \theta$.

$$\begin{aligned} 13. \text{ If the circles } (y - b)^2 + (x - a_1)(x - a_2) &= 0, \\ (y - B)^2 + (x - A_1)(x - A_2) &= 0, \end{aligned}$$

touch each other, prove either

$$(B - b)^2 + (A_1 - a_1)(A_2 - a_2) = 0,$$

or

$$(B - b)^2 + (A_1 - a_2)(A_2 - a_1) = 0.$$

14. $S_1 = 0$ and $S_2 = 0$, are two circles, radii r_1 and r_2 . The circle whose diameter is the distance between their centers of similitude is

$$\frac{S_1}{r_1^2} - \frac{S_2}{r_2^2} = 0.$$

It is called the circle of similitude of the two \odot s.

15. Tangents to these \odot s from any point on their \odot of similitude are in the constant ratio of their radii.

NOTE. — This follows from Ex. 14.

16. The locus of a point P at which the \odot s subtend equal angles is the \odot of similitude.

17. Show that the \odot s

$$\frac{S_1}{r_1} \pm \frac{S_2}{r_2} = 0 \text{ cut orthogonally.}$$

18. Show that the \odot s of Ex. 17 bisect the angles between the circles $S_1 = 0, S_2 = 0$.

19. $S_1 = 0, S_2 = 0$, are two circles ; r_1, r_2 , their radii.

Show that their external and internal centers of similitude are respectively the centers of the \odot s.

$$\frac{S_1}{r_1} - \frac{S_2}{r_2} = 0,$$

$$\frac{S_1}{r_1} + \frac{S_2}{r_2} = 0,$$

and \therefore the six centers of similitude of three \odot s lie, three by three, on four straight lines.

20. Find the locus of the centers of circles, which, viewed from two fixed points, subtend constant angles.

21. Also, the locus of centers of circles which cut each of two given [fixed] circles in the extremities of diameters.

22. Find the locus of a point such that the chords of contact of the tangents drawn from it to three given circles may be concurrent.

23. Find the locus of a point such that the sum of its distances from two or more given straight lines is constant.

24. From a fixed point P tangents are drawn to two \odot s which pass through two fixed points. Find the locus of the intersection of the chord of contact with the diameter through P [in each \odot].

25. A, B, C, D, are four concyclic points, O any other point.

Prove :

$$\overline{OA}^2 \cdot \text{area BCD} + \overline{OC}^2 \cdot \text{area ABD} - \overline{OB}^2 \cdot \text{area ACD} - \overline{OD}^2 \cdot \text{area ABC} = 0.$$

26. Show that the radical axis of a circle and a point bisects the distance between the point and its polar with respect to the circle.

27. T_1, T_2, T_3 , are the lengths of the tangents from any point to three coaxial circles whose centers are A, B, C .

Prove : $BC \cdot T_1^2 + CA \cdot T_2^2 + AB \cdot T_3^2 = 0$.

28. A circle can be inscribed in the quadrilateral formed by the axes and the lines

$$\left. \begin{aligned} x \cos \alpha + y \sin \alpha &= p_1, \\ x \cos \beta + y \sin \beta &= p_2, \end{aligned} \right\} \text{if}$$

$$p_1 [\sin \beta + \cos \beta + 1] = p_2 [\sin \alpha + \cos \alpha + 1].$$

29. Two variable circles, which are tangent to each other, are also tangent to two given circles. Find the locus of the point of contact of the variable circles.

30. A variable circle cuts two given circles at constant angles ϕ_1, ϕ_2 . Show that it cuts their radical axis at a constant angle ψ determined by the equation $d \cos \psi = r_1 \cos \phi_1 - r_2 \cos \phi_2$.

[r_1, r_2 are the radii ; d , the distance between centers.]

31. If R is the radius of the variable \odot in the preceding exercise, and P is the \perp from its center on the radical axis, prove :

$$P = R \cos \psi.$$

32. A series of \odot s are given, which, taken two by two, have the same radical axis. If a variable \odot cuts two of these at constant angles, show that it will cut the remaining circles at constant angles.

33. Prove that a circle which cuts two given circles at constant angles touches two fixed circles.

34. On the axes a variable rectangle $OABC$ is constructed with a given perimeter $= 2p$. Prove that the \perp from vertex C on diagonal AB always passes through a fixed point.

35. Show that the center of the inscribed circle of the Δ whose vertices are $(x_1, y_1), (x_2, y_2), (x_3, y_3)$,

is $\left\{ \frac{ax_1 + bx_2 + cx_3}{a + b + c}, \frac{ay_1 + by_2 + cy_3}{a + b + c} \right\}$,

where a, b, c , are the lengths of sides of Δ .

36. Two \odot s touch each other internally, and a third \odot touches both [one internally and one externally]. Show that the sum of the distances of the center of the third circle from the centers of the two given circles is constant.

37. A variable circle cuts three given \odot s at equal angles. Show that the locus of its center is a \perp from the radical center on one of the axes of similitude.

38. Find the circle which cuts the three circles

$$\left. \begin{aligned} x^2 + y^2 &= a^2, \\ (x - b)^2 + y^2 &= a^2, \\ x^2 + (y - c)^2 &= a^2, \end{aligned} \right\} \text{* orthogonally.}$$

$$\text{Ans. } x^2 + y^2 - bx - cy + a^2 = 0.$$

39. A chord of a \odot moves parallel to itself, and lines are drawn through its extremities to meet at a given angle. Find the locus of their intersection.

40. Find the system of \odot s which cuts orthogonally each of the system

$$x^2 + y^2 + 2\lambda_1 x - a^2 = 0$$

[where λ is a variable parameter].

$$\text{Ans. } x^2 + y^2 + 2\lambda_2 y + a^2 = 0.$$

[where λ_2 is a variable parameter].

41. If the axes make an $\angle = 60^\circ$, find the center and radius of the circle represented by the equation

$$x^2 + xy + y^2 - 4x - 5y - 2 = 0.$$

$$\text{Ans. } (1, 2); 3.$$

* The center of required \odot is radical center ; radius = a tangent therefrom to one of the \odot s.

CHAPTER VI

TRANSFORMATION OF CO-ORDINATES

90. The reference of a curve to a new set of axes sometimes simplifies its equation, and thereby facilitates the investigation of its properties. Of course, a curve remains unchanged by any transformation of co-ordinates, although its equation, whose nature depends in a measure on the relative position of the axes, may assume a slightly different form; and, as we shall see presently, the degree of an equation remains unchanged by any variation of axes. We shall discuss only the most useful forms of transformation.

91. To transfer the origin to the point (h, k) without changing the direction of the axes.

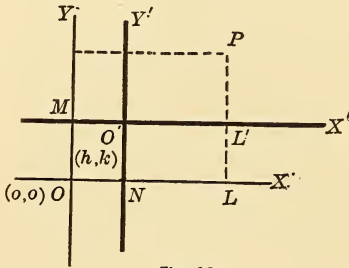

Fig. 99.

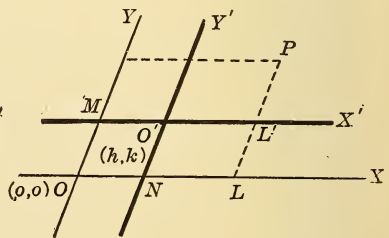

Fig. 100.

OX, OY are the old axes; $O'X', O'Y'$ are the new axes. P is any point in the plane whose co-ordinates are (x, y) to the old axes (x', y') to the new axes.

$$\begin{aligned} \text{Now,} \quad x &= OL = MO' + O'L' \\ &= h + x', \\ y &= PL = NO' + PL' \\ &= k + y'. \end{aligned}$$

Hence, to transform to a new origin (h, k) with new axes parallel to the old, we put $x' + h$ for x , and $y' + k$ for y ; or, in the end, the accents may be dropped, giving

$$\begin{aligned} x + h &\text{ for } x, \\ y + k &\text{ for } y. \end{aligned}$$

NOTE. — To transfer back to the old axes, we put

$$\begin{aligned} x - h &\text{ for } x, \\ y - k &\text{ for } y. \end{aligned}$$

92. To transform from one set of rectangular axes to another, the origin remaining the same; *i.e.*, to turn the axes through a given angle.

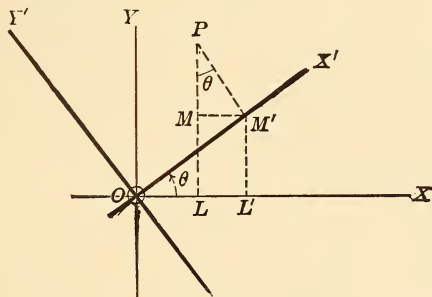

Fig. 101.

P is any point (x, y) old axes, and (x', y') new axes.

PM' is \perp to OX' and $M'M$ is \perp to PL .

$$\begin{aligned} \text{Now} \quad x &= OL = OL' - LL' \\ &= OL' - MM' \\ &= OM' \cos \theta - PM' \sin \theta. \end{aligned}$$

$$\therefore x = x' \cos \theta - y' \sin \theta.$$

$$\text{Similarly,} \quad y = x' \sin \theta + y' \cos \theta.$$

The accents may be dropped after transformation.

The combined changes of §§ 91 and 92 are evidently effected by the use of the formulæ,

$$\begin{aligned}x &= h + x' \cos \theta - y' \sin \theta, \\y &= k + x' \sin \theta + y' \cos \theta.\end{aligned}$$

93. To change from rectangular to oblique axes with the same origin.

The positive directions of the new axes make the angles α and β respectively with the old x -axis.

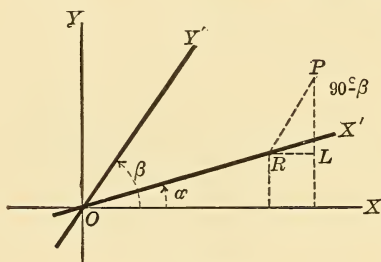

Fig. 102.

These formulæ are readily obtained:

$$\begin{aligned}x &= x' \cos \alpha + y' \cos \beta, \\y &= x' \sin \alpha + y' \sin \beta.\end{aligned}$$

If we take $\beta = 90^\circ + \alpha$, these formulæ reduce to those of § 92.

The combined changes of §§ 91 and 93 are represented thus:

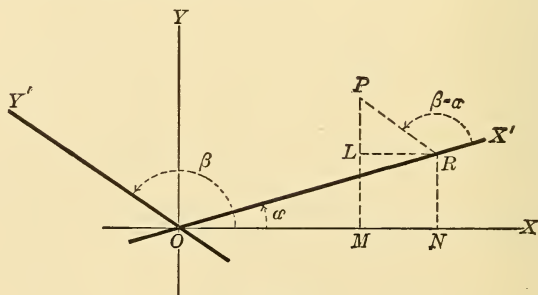

Fig. 103.

$$\begin{aligned}x &= h + x' \cos \alpha + y' \cos \beta, \\y &= k + x' \sin \alpha + y' \sin \beta.\end{aligned}$$

94. To transform from one set of oblique axes to another.

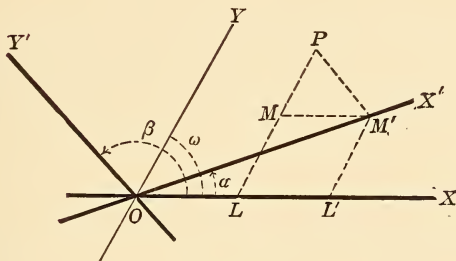

Fig. 104.

PM' is \parallel to OY' , PL and $M'L'$ are \parallel to OY , MM' is \parallel to OX

Now from $\triangle OL'M'$,

$$OL' = x' \frac{\sin(\omega - \alpha)}{\sin \omega},$$

and

$$L'M' = x' \frac{\sin \alpha}{\sin \omega}.$$

Also, from $\triangle PMM'$,

$$MM' = y' \frac{\sin(\beta - \omega)}{\sin \omega},$$

and

$$MP = y' \frac{\sin \beta}{\sin \alpha}.$$

Now $x = OL = OL' - MM' = x' \frac{\sin(\omega - \alpha)}{\sin \omega} - y' \frac{\sin(\beta - \omega)}{\sin \omega}.$

$$y = LP = L'M' + MP = x' \frac{\sin \alpha}{\sin \omega} + y' \frac{\sin \beta}{\sin \omega}.$$

$$\therefore x = x' \frac{\sin(\omega - \alpha)}{\sin \omega} + y' \frac{\sin(\omega - \beta)}{\sin \omega},$$

$$y = x' \frac{\sin \alpha}{\sin \omega} + y' \frac{\sin \beta}{\sin \omega}.$$

95. It has thus been seen that in the transformation of axes, the co-ordinates x and y are replaced by expressions of the first degree: functions of x' , y' , the new co-ordinates, and certain angles made by the axes with each other. Hence, the degree of an equation cannot be raised. Likewise it cannot be lowered, for in that case the degree of the new equation could be raised by reverting to the old axes. \therefore , etc.

MISCELLANEOUS EXERCISES.

1. M is the mid-point of side BC of $\triangle ABC$. Prove analytically,

$$\overline{AB}^2 + \overline{AC}^2 = 2 \overline{AM}^2 + 2 \overline{BM}^2.$$

2. Show that the diagonals of the rectangle formed by the lines

$$\left. \begin{array}{l} x = a_1, \\ x = a_2, \end{array} \right\} \quad \left. \begin{array}{l} y = b_1, \\ y = b_2, \end{array} \right\} \text{ are}$$

$$\left. \begin{array}{l} (b_1 - b_2)x - (a_1 - a_2)y + a_1b_2 - a_2b_1 = 0, \\ (b_1 - b_2)x + (a_1 - a_2)y - a_1b_1 + a_2b_2 = 0, \end{array} \right\}$$

3. Menelaus' Theorem: If a straight line meets the sides of a $\triangle ABC$ in X, Y, Z, prove

$$\frac{BX}{XC} \cdot \frac{CY}{YA} \cdot \frac{AZ}{ZB} = -1.$$

SUGGESTION. — Take A (x_1, y_1) , B (x_2, y_2) , etc., and given line

$$ax + by + c = 0,$$

find values for the ratios.

4. The equation

$$2Hxy + 2Gx + 2Fy + c = 0$$

represents two straight lines if $2FG = CH$.

Show also that these lines form a \sphericalangle with the axes.

5. Show that the lines

and $\left. \begin{array}{l} \tan \alpha = \frac{y}{x} \\ x \cos \alpha + y \sin \alpha = a \end{array} \right\} \begin{array}{l} \text{bisect the angles between the lines} \\ \text{represented by the equation} \end{array}$

$$(x - a \cos \alpha)^2 + (y - a \sin \alpha)^2 = k^2 \{x \cos \alpha + y \sin \alpha - a\}^2.$$

6. Show that the diagonals of the \square , Ex. 4, are

$$\left. \begin{aligned} \frac{x}{F} - \frac{y}{G} &= 0, \\ \frac{x}{F} + \frac{y}{G} + \frac{1}{H} &= 0. \end{aligned} \right\}$$

7. Determine k so that the equation

$$k(x^2 + y^2 - a^2) + \left\{ x \cos \left(\frac{\alpha + \beta}{2} \right) + y \sin \left(\frac{\alpha + \beta}{2} \right) - a \cos \left(\frac{\alpha - \beta}{2} \right) \right\} \\ \left\{ x \cos \left(\frac{\alpha + \gamma}{2} \right) + y \sin \left(\frac{\alpha + \gamma}{2} \right) - a \cos \left(\frac{\alpha - \gamma}{2} \right) \right\} = 0$$

may represent two straight lines.

$$\text{Ans. } k = \left\{ \sin \left(\frac{\alpha - \beta}{2} \right) \sin \left(\frac{\gamma - \alpha}{2} \right) \right\}.$$

EXERCISES ON CHAPTER VI.

Transform

- $4x - 5y - 6 = 0$ to \parallel axes through $(2, -5)$.
- $x + 2y - 1$ to \parallel axes through $(1, 4)$.
- $x^2 + y^2 - 8x + 6y - 12 = 0$ to \parallel axes through $(-1, -3)$.
- $2x^2 - 6y^2 - 4y + 5x - 9 = 0$ to \parallel axes through $(-3, 4)$.
- $x - 2y - 9 = 0$ to \parallel axes through $(-5, -3)$.

Turn the axes through 45° in the equations

- $x^2 - y^2 = 4$. Ans. $xy + 2 = 0$.
- $2y - 3x + 1 = 0$.
- $3x^2 - 4xy + 3y^2 + 24 = 0$.
- $x^4 + y^4 + 6x^2y^2 - 2 = 0$. Ans. $x^4 + y^4 - 1 = 0$.
- $\frac{x^2}{4} + \frac{y^2}{9} = 1$.
- Turn the axes through $\angle \phi$ in $x^2 + y^2 = r^2$.
Why is there no change in the equation?
- Turn the axes through an angle $= \tan^{-1} \frac{3}{4}$ in $2x^2 - 5xy + x - 4 = 0$.
- Transform $x^2 + y^2 - 5 = 0$ to \parallel axes through $(1, 1)$.
- Transform $x^2 + y^2 - 2x = 0$ to \parallel axes through $(1, 1)$.
Ans. $x^2 + y^2 + 2y = 0$.

15. What does the equation $\frac{x^2}{4} - \frac{y^2}{1} = 1$ become, if the new axes make \angle s, $\tan^{-1} \pm \frac{1}{2}$ with the old axis, and origin is unchanged?

Ans. $4xy = 5$.

Transform to polar co-ordinates, pole at origin,

16. $x^2 + y^2 = r^2$.

21. $2x + 3y - 1 = 0$.

17. $x^2 + 2ax - y - 12 = 0$.

22. $x - 2y + 4 = 0$.

18. $x^2 + y^2 = 6x$.

23. $x \cos a + y \sin a = p$.

19. $y = 3x$.

24. $\frac{x}{a} + \frac{y}{b} = 1$.

20. $x^2 - y^2 = a^2$.

25. $x - ky - a = 0$.

26. Transform $x^2 + y^2 - 8x + 6y - 14 = 0$, pole at $(1, \epsilon)$, polar axis \parallel to x -axis.

27. Transform $x^2 + y^2 + 4x - 2y + 1 = 0$, pole at $(-2, -5)$, polar axis at 30° to x -axis.

28. Turn axes through 45° in $5x^2 + 6xy + 5y^2 - 8 = 0$ [rectangular axes].

Ans. $4x^2 + y^2 - 4 = 0$.

29. Also in $x^2 - y^2 = 2$.

Ans. $xy = -1$.

30. In $x^2 + 2xy \tan 2\phi - y^2 = 2a^2$, turn axes through $\angle \phi$.

Ans. $x^2 - y^2 = 2a^2 \cos 2\phi$.

31. If, in turning a pair of rectangular axes through $\angle \theta$, the equation becomes

$$Ax^2 + 2Hxy + By^2 = 0$$

prove

$$A'x'^2 + 2H'x'y' + B'y'^2 = 0,$$

$$\left. \begin{aligned} A' + B' &= A + B, \\ A'B' - H'^2 &= AB - H^2. \end{aligned} \right\}$$

In the same transformation, prove

$$x'^2 + y'^2 = x^2 + y^2.$$

Transform to rectangular co-ordinates,

32. $\rho^2 \sin 2\theta = a^2$.

36. $\tan 2\theta = ab$.

33. $\rho^2 \cos 2\theta = 4$.

37. $\sec \theta = 1\frac{1}{2}$.

34. $\rho = 5$.

38. $\rho = a \sin \theta \cos \theta$.

35. $\rho = 4 \sin \theta$.

39. $\rho = \frac{1}{a} \cdot \frac{1}{b} \cos 2\theta$.

Transform to polar co-ordinates, pole at origin,

40. $x^3 - 3x^2y - 3xy^2 + y^3 = 0$.

Ans. $\tan 3\theta = 1$.

41. $mx^3 - 3mxy^2 + y^3 - 3x^2y = 0$.

Ans. $\tan 3\theta = m$.

42. Transform to rectangular co-ordinates, $\rho^{\frac{1}{2}} \cos^{\frac{1}{2}} \theta = a^{\frac{1}{2}}$.

43. Transform $x^2 - 2xy + 2y^2 - 4x + 6y = 0$ to axes turned through $\tan^{-1} \frac{2}{3}$.

44. To what point must the origin be moved [axes parallel to old position] in order that the equation

$$(\alpha) \quad 5x^2 + 4xy + 8y^2 - 18x - 36y + 9 = 0$$

may have no terms of the first degree ?

Ans. (1, 2).

SUGGESTION. — Let (x', y') be the new origin. Transform, and equate coefficients of x and y to zero. Solve for x', y' , etc.

$$(\beta) \quad xy - ax - by = 0.$$

Ans. (b, a).

45. Through what angle must the axes be turned in order to remove from the equation $Ax + By + C = 0$ the x -term? the y -term?

$$Ans. \quad \theta = \tan^{-1} - \frac{A}{B}.$$

$$\theta = \tan^{-1} \frac{B}{A}.$$

46. Through what angle should the axes be turned so that the xy = term in the equation

$$4x^2 - 24xy + 11y^2 + 20 = 0 \text{ may disappear ?}$$

Ans. $\theta = \tan^{-1} \frac{3}{4}$.

47. (x, y) are the co-ordinates of a point referred to rectangular axes. Find its co-ordinates referred to the lines

$$\frac{x^2}{a^2} - \frac{y^2}{b^2} = 0, \text{ as axes.}$$

$$Ans. \quad \left\{ \frac{1}{2} \sqrt{a^2 + b^2} \left(\frac{x}{a} - \frac{y}{b} \right), \quad \frac{1}{2} \sqrt{a^2 + b^2} \left(\frac{x}{a} + \frac{y}{b} \right) \right\}$$

48. Determine θ so that the xy -term in

$$x^2 + xy + y^2 - 3x - 3y = 0 \text{ may vanish.}$$

Ans. $\theta = 135^\circ$.

49. Through what angle should the axes be turned so that x -axes may pass through $(-4, 12)$ in $4x - 3y + 6 = 0$?

CHAPTER VII

THE PARABOLA

96. Definition of Conic. — A conic section or a conic is the locus of a point which moves in a plane so that its distance

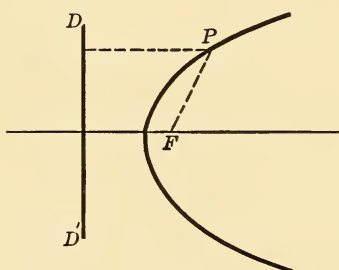

Fig. 105.

from a fixed point called the **focus** bears a constant ratio to its distance from a fixed straight line called the **directrix**. This ratio is denoted by e or $e : 1$. Thus, if P is any point of the conic, F the focus, and DD' the directrix, we have

$$PF = e \cdot PD \text{ always.}$$

The ratio e is called the **eccentricity**.

- When $e = 1$, the conic is called a **Parabola**.
- When $e < 1$, an **Ellipse**.
- When $e > 1$, an **Hyperbola**.

EXAMPLE 1. Find the equation of the parabola, focus at the point $(2, 3)$, and directrix the line $3x + 4y - 2 = 0$.

Let (x, y) be any point of the required parabola.

Its distance from the focus is $\sqrt{(x - 2)^2 + (y - 3)^2}$

and distance from the directrix is $\frac{3x + 4y - 2}{\pm 5}$.

$$\therefore (x - 2)^2 + (y - 3)^2 = \left(\frac{3x + 4y - 2}{\pm 5} \right)^2 \text{ is the required equation.}$$

Ex. 2. Find the equation of the ellipse focus $(1, 1)$ and directrix $2x - y - 1 = 0$, eccentricity $= \frac{3}{5}$.

Here
$$\sqrt{(x-1)^2 + (y-1)^2} = \frac{3}{5} \left(\frac{2x-y-1}{\pm\sqrt{5}} \right)$$

is the required equation.

EX. 3. Find the equation of the hyperbola focus (2, 0), directrix $x-9=0$, eccentricity $\frac{3}{2}$.

$$\sqrt{(x-2)^2 + y^2} = \frac{3}{2} (x-9)$$
 is the required equation.

97. Equation of the parabola. Type-form.—Let F be the focus, DD' the directrix, and a \perp to DD', drawn through

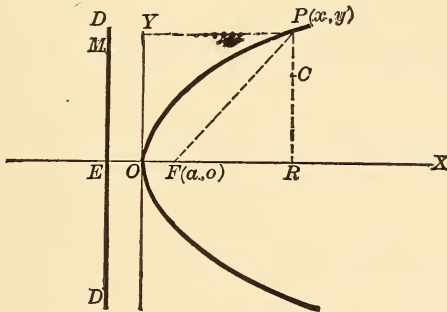

Fig. 106.

F, the x -axis. Bisect EF in O, which is called the **vertex**, and which by definition is a point on the curve. Let O be the origin.

Let $OF = a$ [known distance].

Now $PF = PM = ER$ [by def.]

$$\overline{PF}^2 = \overline{PR}^2 + \overline{FR}^2, \text{ or } \overline{ER}^2 = \overline{PR}^2 + \overline{FR}^2.$$

$$\therefore (x+a)^2 = y^2 + (x-a)^2,$$

whence
$$y^2 = 4ax \dots \dots \dots (1)$$

is the required equation.

DISCUSSION. — Equation (1) shows

(1) Curve is symmetrical with regard to x -axis or its own axis.

(2) Curve lies wholly on same side of y -axis (i.e., x always has the same sign as the constant a), since negative values of x give imaginary values for y .

(3) When $x = \infty, y = \infty$, \therefore curve is open, extending to the right without limit.

NOTE 1. — Equation of directrix is $x + a = 0$.

NOTE 2. — $FP = EO + OR = x + a$.

QUERY. — What curves are these ?

$$x^2 = 4ay,$$

$$y^2 = -4ax,$$

$$x^2 = -4ay.$$

98. Construction of parabola, focus and directrix given. —

(1) *By points.*

DD' is directrix, F the focus. Draw $FE \perp$ to DD' . Bisect EF in O , which is called the vertex, a point on the curve. At

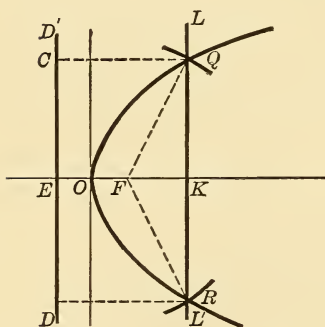

Fig. 107.

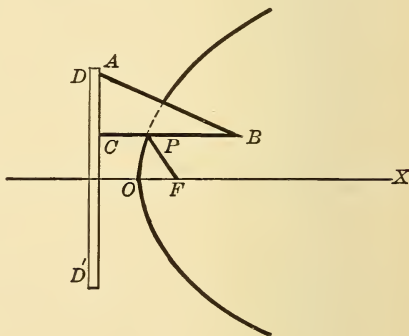

Fig. 108.

any point K of EF (produced if necessary) erect the $\perp LL'$. Now with F as center and EK as radius, cut this \perp in Q and R . These are two points on the curve. For $FQ = EK = CQ$. In this manner any number of points may be found and joined by a continuous curve.

(2) *Mechanically.*

Place a ruler in coincidence with the directrix DD' , and a right triangular ruler with one edge AC against the ruler. Take a string of length BC , fasten one end to B , and the other

end to the focus F. Then slide $\triangle ABC$ along the edge of the ruler at directrix, keeping the string tightly pressed against the edge BC by a pencil-point P. This point will trace the required parabola. For $PF = PC$ always.

99. Internal and external points.—If C is any point (x, y) within a parabola [See Fig. 106, § 97] $y^2 = 4ax$, we have

$$\begin{aligned} y^2 - 4ax &= \overline{CR}^2 - 4a \cdot OR \quad [\text{for the point C}] \\ &= \overline{CR}^2 - \overline{PR}^2, \text{ which is negative.} \end{aligned}$$

Hence the $y^2 - 4ax$ of an internal point is negative, and $y^2 - 4ax$ of an external point is positive, and equal to zero for a point on the curve.

100. The latus rectum [the double ordinate through the focus] is a third proportional to any abscissa and its corresponding ordinate.

In $y^2 = 4ax$, put $x = a$, $\therefore 2y = 4a$ [= latus rectum].

Also, $x : y :: y : 4a$. Hence, etc.

101. The Squares of any two ordinates of a parabola are to each other as their corresponding abscissas.

Let (x_1, y_1) and (x_2, y_2) be any two points on the curve.

Then

$$y_1^2 = 4ax_1,$$

$$y_2^2 = 4ax_2.$$

$$\therefore y_1^2 : y_2^2 :: x_1 : x_2. \quad \therefore, \text{ etc.}$$

EXERCISES.

1. Is the point $(3, -2)$ outside or inside of $y^2 = 6x$?
2. The vertices of an equilateral \triangle are on $y^2 = 4ax$, one of them at the vertex. Show that its side has the length $8a\sqrt{3}$.
3. At what point of $y^2 = 16x$ is the ordinate twice the abscissa?
4. Find where the line $ax + by = 1$ cuts the parabola $y^2 = 4ax$.
5. Find the equation of the line through the focus of $y^2 = 4ax$ and at 45° to x -axis.

6. A chord PP' passes through the fixed point K on the axis of a parabola. N and N' are the feet of \perp s from P and P' on the axis. Prove $ON \cdot ON' = AK^2$ [constant]. See Fig. 106, § 97.

7. PFQ is a focal chord, PO meets the directrix in K . Prove QK is parallel to the axis of the parabola.

8. Find the chord made by $y - 2x - 1 = 0$ with $y^2 = 12x$.

9. Find co-ordinates of foci, equations of directrices, and lengths of latera-recta in the parabolas,

$$(1) y^2 + 4ax = 0. \quad (3) (y + 4)^2 = 6(x + 5). \quad (5) y^2 = ax.$$

$$(2) x^2 + 4by = 0. \quad (4) y^2 + 6x + 8 = 0. \quad (6) x^2 = by.$$

10. Find the equation of the parabola through the origin, and $(3, 4)$ its axis being the x -axis.

Let $y^2 = kx$ be equation required.

Then $16 = 3k$, whence, $k = \frac{16}{3}$, etc.

11. The vertices of a Δ are three points on the parabola $y^2 = 4ax$ whose ordinates are y_1, y_2, y_3 . Prove,

$$\text{area of } \Delta = \frac{1}{8a} (y_1 - y_2)(y_2 - y_3)(y_3 - y_1).$$

12. Two chords through the vertex whose lengths are C_1, C_2 , are \perp to each other. Prove $C_1^{\frac{2}{3}} C_2^{\frac{2}{3}} = 16a^2 (C_1^{\frac{1}{3}} + C_2^{\frac{1}{3}})$.

13. Show that the line $y = x + 2$ touches $y^2 = 8x$. Find the point of contact.

102. Equation of tangent to the parabola at point (x_1, y_1) . — We shall employ the secant method here as in the circle. It is applicable to any curve.

Let (x_2, y_2) be an adjacent point. Then the line joining the two points is

$$\frac{y - y_1}{x - x_1} = \frac{y_1 - y_2}{x_1 - x_2} \quad \dots \dots \dots (1)$$

Also,

$$y_1^2 = 4ax_1, \quad y_2^2 = 4ax_2,$$

$$\therefore y_1^2 - y_2^2 = 4a(x_1 - x_2).$$

$$\therefore \frac{y_1 - y_2}{x_1 - x_2} = \frac{4a}{y_1 + y_2}.$$

Hence (1) becomes,

$$\frac{y - y_1}{x - x_1} = \frac{4a}{y_1 + y_2},$$

or $y(y_1 + y_2) - 4ax = y_1^2 + y_1y_2 - 4ax_1$
 $= y_1y_2$ [since $y_1^2 = 4ax_1$] . . . (2)

Now put

$$y_2 = y_1, \quad x_2 = x_1,$$

$$\therefore 2yy_1 - 4ax = y_1^2 = 4ax_1.$$

$$\therefore y^2 = 2a(x + x_1) (3)$$

is the required equation.

EXAMPLE. — Tangent at vertex (0, 0) is $0 = 2ax$, or $x = 0$ [*y*-axis.]

The normal is $\frac{y - y_1}{y_1} = \frac{x - x_1}{-2a},$
 or $2a(y - y_1) + y_1(x - x_1) = 0 (4)$

NOTE. — Equation (2) above, of the chord, is sometimes useful.

103. Equation of parabola with origin (h, k). — If the vertex of the parabola [the origin] is removed to (h, k) with its axis parallel to the *x*-axis, its equation is evidently

$$(y - k)^2 = 4a(x - h).$$

Different positions of the curves are indicated by these equations,

$$(x - h)^2 = \pm 4a(y - k),$$

$$(y - k)^2 = \pm 4a(x - h), \text{ etc.}$$

which the student can easily interpret.

104. Any equation of the form $Ax^2 + 2Gx + 2Fy + C = 0$, or $By^2 + 2Gx + 2Fy + C = 0$, represents a parabola. — We shall take a special example for illustration.

Find focus, vertex, latus rectum, directrix, etc., of the curve

$$y^2 + 2y - 12x - 11 = 0.$$

This may be written thus,

$$y^2 + 2y + 1 = 12(x + 1),$$

or, $(y + 1)^2 = 4.3(x + 1).$

Hence, comparing with the type-form $(y - k)^2 = 4a(x - h)$, we see that the vertex is the point $(-1, -1)$, the latus rectum is $4a = 4 \cdot 3 = 12$.

Since $a = 3$, and vertex is $(-1, -1)$. \therefore focus is $(2, -1)$ [add 3 to -1].

The directrix is $x = -4$, the axis of curve is $y = -1$.

Hence the curve has its axis parallel to the x -axis and extends to the right.

The two equations at the beginning of this section can, in a similar way, be shown to represent parabolas.

105. Equation of tangent in terms of slope. — The abscissas of the points of intersection between the line $y = mx + b$ and the parabola $y^2 = 4ax$, are determined by the equation

$$(mx + b)^2 = 4ax,$$

or
$$m^2x^2 + (2bm - 4a)x + b^2 = 0 \quad \dots \quad (1)$$

Its roots are equal, *i.e.*, the line is a tangent if

$$(bm - 2a)^2 = b^2m^2.$$

$$\therefore 4a^2 - 4abm = 0, \quad b = \frac{a}{m}.$$

$$\therefore y = mx + \frac{a}{m}$$

is a tangent to the parabola for all values of m .

Again substituting this value of b in (1), it becomes

$$\left(mx - \frac{a}{m}\right)^2 = 0, \quad \text{or} \quad x = \frac{a}{m^2}$$

[abscissa of point of contact].

Substituting in
$$y^2 = 4ax,$$

we get
$$y = \frac{2a}{m}.$$

Hence the point of contact of the tangent is $\left(\frac{a}{m^2}, \frac{2a}{m}\right)$.

106. Normal in terms of slope. — Let m_1 be the slope of the normal, then

$$m_1 = -\frac{1}{m}.$$

Again, the equation of the normal is

$$\left(y - \frac{2a}{m}\right) = -\frac{1}{m}\left(x - \frac{a}{m^2}\right) \dots \dots \dots (2)$$

Substituting m_1 for $-\frac{1}{m}$ in this equation, we get

$$y = mx - 2am_1 - am_1^3,$$

which is the equation of the normal in terms of its own slope m_1 .

EXERCISES.

1. Find a point on $y^2 = 4ax$ where the tangent is at 30° to x -axis.

Ans. $(\frac{2}{3}a, a\sqrt{3})$.

2. The curves $y^2 = ax$, $x^2 = by$, meet at an angle =

$$\tan^{-1} \frac{3a^{\frac{1}{3}}b^{\frac{1}{3}}}{2(a^{\frac{2}{3}} + b^{\frac{2}{3}})}.$$

3. A tangent at P meets directrix in M. Prove PM subtends a right angle at the focus F.

4. Find the tangents to $y^2 = 4ax$ at 30° to x -axis.

5. Find the equation of a parabola whose axis is parallel to the x -axis, and which is tangent to the line $y - 2x - 1 = 0$.

6. A chord PQ of $y^2 = 4ax$ subtends a right angle at the vertex. Show that it passes through the fixed point $(4a, 0)$.

7. A \odot described on a focal chord as diameter is tangent to the directrix.

8. The tangent at any point of a parabola meets the directrix and latus rectum produced at points equidistant from the focus.

9. Find the focus and directrix of the parabola represented by the equation $x^2 + 2ax + 4by + 4bc + a^2 = 0$.

Ans. $(-a, -c - b)$, $y = b - c$.

10. Find the equation of a tangent drawn from $(9, -14)$ to $y^2 = 6x$.
11. Find the equations of the tangent and normal to $y^2 = 8ax$ at $(2, 4)$.
12. Show that the tangents at (x_1, y_1) and (x_2, y_2) meet in the point

$$\left(\frac{y_1 y_2}{4a}, \frac{y_1 + y_2}{2} \right).$$

13. The sum of the subtangent and subnormal for any point on $y^2 = 4ax$, equals $\frac{1}{2}$ length of the focal chord parallel to the tangent at the given point.

14. From any point on the latus rectum \perp s are drawn to the tangents at its extremities. Show that the join of the feet of these \perp s touches the parabola.

15. N is foot of \perp from focus on tangent at P.

Prove $\overline{FN}^2 = FO \cdot FP$.

16. The \angle between two tangents to a parabola = $\frac{1}{2}$ \angle between the focal radii of the points of contact.

17. A triangle is circumscribed about a parabola, *i.e.*, is formed by three tangents. Prove,

- (1) The Δ formed by them is $\frac{1}{2}$ the area of the Δ formed by the points of contact.
- (2) Its orthocenter lies on the directrix of the parabola.
- (3) Its circumscribed circle passes through the focus.
- (4) The area of the $\Delta = \frac{1}{8a} (p_1 - p_2) (p_2 - p_3) (p_3 - p_1)$ where $4a =$ latus rectum, and $p_1, p_2, p_3,$ are the \perp s dropped from the points of contact on the axis.

18. Find the locus of the center of an equilateral Δ formed by three tangents or three normals to a parabola.

19. If \perp s be dropped on a tangent to a parabola from two points on the axis equidistant from focus, the difference of their squares will be constant. If $P_1, P_2,$ are the points, the product = $2a \cdot P_1 P_2$.

20. The tangent at one extremity of a focal chord is parallel to the normal at the other extremity.

SUGGESTION. — Let $(x_1, y_1), (x_2, y_2),$ be the extremities.

Show the condition that the line joining them passes through the focus is

$$y_1 y_2 + 4a^2 = 0.$$

Find tangents at the points, etc.

Let FM and PT meet in R. Then \triangle PRF and PRM are equal. (Why?)

$$\therefore \angle PRF = \angle PRM.$$

\therefore R is the foot of the \perp from focus to the tangent.

Also, since $FR = MR$, and $FO = OC$,

\therefore OR is parallel to CM. \therefore , etc.

(6) If the tangents at Q and Q' meet in T, then a parallel to the axis through T bisects QQ'. (The student should draw the figure.)

Let Q and Q' be (x_1, y_1) and (x_2, y_2) respectively.

Then the equations of QT and Q'T are

$$yy_1 = 2a(x + x_1) \dots \dots \dots (1)$$

$$yy_2 = 2a(x + x_2) \dots \dots \dots (2)$$

Solve for the co-ordinates of T.

By subtraction,

$$y(y_1 - y_2) = 2a(x_1 - x_2)$$

$$= \frac{1}{2}(y_1^2 - y_2^2).$$

$$\therefore y = \frac{1}{2}(y_1 + y_2),$$

which is the equation of the parallel to the x -axis through T. It evidently passes through the mid-point of QQ'. \therefore , etc.

NOTE. — The co-ordinates of the point of contact of the tangent [§105] may be found thus :

The tangent $yy_1 = 2a(x + x_1)$ may be written

$$y = \frac{2a}{y_1}x + \frac{2ax_1}{y_1}.$$

Comparing this with $y = mx + \frac{a}{m}$,

we have $m = \frac{2a}{y_1}$. $\therefore y_1 = \frac{2a}{m}$,

and $\frac{a}{m} = \frac{2ax_1}{y_1} = \frac{2ax_1}{\frac{2a}{m}} = mx_1$.

$$\therefore x_1 = \frac{a}{m^2}.$$

∴ point of contact of the tangent $y = mx + \frac{a}{m}$ is $\left(\frac{a}{m^2}, \frac{2a}{m}\right)$.

108. Tangents to a parabola from a given point. —

$y = mx + \frac{a}{m}$ is the tangent for all values of m . If it pass through any point (x_1, y_1) , we have

$$y_1 = mx_1 + \frac{a}{m}.$$

$$\therefore m = \frac{y_1 \pm \sqrt{y_1^2 - 4ax_1}}{2x_1}.$$

These values are (1) real and unequal, (2) equal, or (3) imaginary, according as $y_1^2 - 4ax_1 >, =, \text{ or } < 0$. ∴ two distinct, two coincident, or no tangents can be drawn from a given point to a parabola according as that point is outside, on, or within the parabola.

109. Normals from a given point. — The equation to the normal in terms of its own slope m_1 is,

$$y = m_1x - 2am_1 - am_1^3.$$

There are, in general, three roots of this cubic in m_1 , some of which may be imaginary. However, at least one normal can be drawn to a parabola from a given point.

110. To find the locus of the foot of a perpendicular from the focus to a tangent. — Any tangent is

$$y = mx + \frac{a}{m} \dots \dots \dots (1)$$

A \perp to it from focus $(a, 0)$ is

$$y = -\frac{1}{m}(x - a) \dots \dots \dots (2)$$

Eliminate m from (1) and (2) by subtraction,

$$\therefore \left(m + \frac{1}{m}\right)x = 0,$$

∴ $x = 0$ [the tangent at vertex]. ∴, etc.

111. Locus of intersection of two tangents \perp to each other.

Let the tangents be

$$y = mx + \frac{a}{m} \dots \dots \dots (1)$$

$$y = m_1x + \frac{a}{m_1} \dots \dots \dots (2)$$

$$\therefore mm_1 = -1 \dots \dots \dots (3)$$

[Eliminate m from (1), (2), (3).]

Subtract (2) from (1) and divide by $(m - m_1)$.

$$\therefore 0 = x - \frac{a}{mm_1} = x + a.$$

$\therefore x + a = 0$ [the directrix] is the required locus, etc.

112. Angle between two tangents from (x_1, y_1) .

The tangent $y = mx + \frac{a}{m}$

passes through (x_1, y_1) if $y_1 = mx_1 + \frac{a}{m}$,

or $m^2x_1 - my_1 + a = 0 \dots \dots \dots (1)$

This equation shows that generally two tangents can be drawn from a given point. [See § 108.]

Let m and m_1 be the roots. Then the tangents are

$$y = mx + \frac{a}{m}, \quad y = m_1x + \frac{a}{m_1}.$$

If ϕ is the angle between them,

$$\tan \phi = \frac{m - m_1}{1 + mm_1}.$$

From (1), $m + m_1 = \frac{y_1}{x_1}$, $mm_1 = \frac{a}{x_1}$.

$$\therefore (m - m_1)^2 = (m + m_1)^2 - 4mm_1 = \frac{y_1^2 - 4ax_1}{x_1^2}.$$

$$\tan \phi = \frac{\sqrt{y_1^2 - 4ax_1}}{a + x_1}.$$

EXERCISES.

1. Find the locus of a point from which the sum of the squares of the normals drawn to a parabola = k^2 [a constant].

2. The locus of the foot of a \perp from focus on a normal is the parabola $y^2 = a(x - a)$.

3. The tangent at the extremity of the latus rectum is twice as far from focus as from vertex.

4. A parabola moves parallel to itself so that the vertex traces the parabola in its original position. Tangents are drawn from vertex of fixed parabola to the movable parabola. Find locus of the points of contact.

5. The circle on any focal radius as diameter touches the tangent [to the parabola] at the vertex.

6. Tangents are drawn to $y^2 = 4ax$ at points whose abscissæ are in the ratio $r : 1$. Show that the locus of their intersection is the parabola $y^2 = (r^{\frac{1}{2}} + r^{-\frac{1}{2}})^2 ax$.

7. Find the equations of the parabola referred to (1) the axis and directrix, (2) axis and latus rectum.

8. Tangents $y = m_1x + \frac{a}{m_1}$, $y = m_2x + \frac{a}{m_2}$, meet in the point $\left\{ \frac{a}{m_1 m_2}, a \left(\frac{1}{m_1} + \frac{1}{m_2} \right) \right\}$.

9. The \perp from the intersection of

$$\left. \begin{aligned} y &= m_1x + \frac{a}{m_1} \\ y &= m_2x + \frac{a}{m_2} \end{aligned} \right\}$$

on

$$y = m_3x + \frac{a}{m_3}$$

meets the directrix in the point

$$\left\{ -a, a \left(\frac{1}{m_1} + \frac{1}{m_2} + \frac{1}{m_3} + \frac{1}{m_1 \cdot m_2 \cdot m_3} \right) \right\}^*$$

10. Tangents to a parabola at M and M' meet in P.

Prove, $\frac{PM^2}{MF} = \frac{PM'}{M'F}$ [where F is focus].

* The symmetry of this result shows that the orthocenter of a Δ circumscribed to the parabola lies on the directrix.

113. Diameters. — Let any chord of a parallel system in a parabola be $y = mx + b$, and let (x_1, y_1) and (x_2, y_2) be its extremities.

Then, if (x, y) is its mid-point, we have

$$2x = x_1 + x_2, \quad 2y = y_1 + y_2.$$

Again,
$$m = \frac{4a}{y_1 + y_2} = \frac{4a}{2y} = \frac{2a}{y}.$$

$$\therefore y = \frac{2a}{m}$$

is the equation of the diameter bisecting the chords \parallel to

$$y = mx + b.$$

DISCUSSION. (1) Every diameter is a straight line parallel to axis of the parabola.

(2) Any line parallel to the axis is a diameter, for m and $2a$ may have any value.

(3) The tangent drawn through the end of a diameter is parallel to the chords of that diameter.

EXERCISES.

1. The \perp from the focus to the chord $y = mx + b$ meets the diameter of this chord in the directrix.

2. The \perp from the focus to a tangent and the diameter through the point of contact meet in the directrix.

3. The tangents through the extremities of a focal chord intersect on the directrix and at right angles.

4. The axis of the parabola is the only diameter which is perpendicular to the tangent at its extremity.

5. A diameter lies above or below the axis according as its chords make an acute or obtuse angle (positive) with the axis.

114. The chord of contact of the point (x_1, y_1) . — Let (x_2, y_2) , (x_3, y_3) , be the points of contact of the tangents drawn to the parabola from (x_1, y_1) .

Then the tangents are,

$$yy_2 = 2a(x + x_2) \dots \dots \dots (1)$$

$$yy_3 = 2a(x + x_3) \dots \dots \dots (2)$$

But both these pass through (x_1, y_1)

$$\therefore y_1y_2 = 2a(x_1 + x_2) \dots \dots \dots (3)$$

and

$$y_1y_3 = 2a(x_1 + x_3) \dots \dots \dots (4)$$

From (3) and (4) it is evident that both the points (x_2, y_2) , (x_3, y_3) , lie on the line whose equation is

$$yy_1 = 2a(x + x_1) \dots \dots \dots (5)$$

which is the required equation of the chord of contact.

If (x_1, y_1) is on the curve, (5) is also a tangent at that point. \therefore the chord of contact of a point on the parabola is coincident with the tangent at that point.

115. Polar of (x_1, y_1) with respect to the parabola $y^2 = 4ax$.—Let the tangents at the ends of the chord revolving about the fixed point (x_1, y_1) intersect in (x_2, y_2) .

To find the locus of point (x_2, y_2) .

The chord of contact of this point is

$$yy_2 = 2a(x + x_2) \dots \dots \dots (1)$$

and since it passes through (x_1, y_1) , we have

$$y_1y_2 = 2a(x_1 + x_2) \dots \dots \dots (2)$$

Hence from (1) and (2) it is seen that the point (x_2, y_2) always lies on the line

$$yy_1 = 2a(x + x_1),$$

which is therefore the required locus or the polar of (x_1, y_1) with respect to the parabola.

When the point (x_1, y_1) is on the curve, the polar coincides with the tangent.

When (x_1, y_1) is outside, the polar is the chord of contact for that point. In general, the properties of the pole and polar proved in the chapter on the circle, will be found to be true for the conic sections.

NOTE. — The polar of the focus (a, o) is $x + a = 0$ [the directrix].
 \therefore tangents at the extremities of a focal chord meet on the directrix.

NOTE on tangents:

(1) To construct a tangent to a parabola at a given point P, take

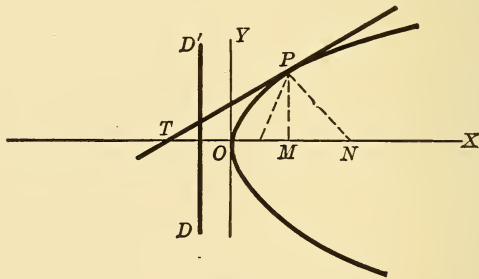

Fig. 110.

$MN = 2a$ and draw $PT \perp$ to PN ; or take $OT = OM$ and draw PT . In either way PT will be tangent at P. [Why?]

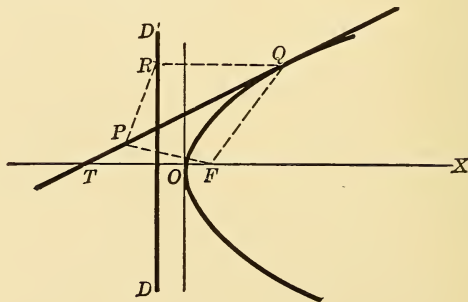

Fig. 111.

(2) To draw a tangent to a parabola from an external point P. With P as center, and PF as radius, cut the directrix in R. Draw RQ parallel

to FX and cutting the parabola in Q. Draw PQ, which is the tangent required. For PF = PR, QF = QR,

\therefore PQ bisects angle FQR. \therefore , etc.

(3) To find the locus of the intersection of two tangents which cut at a given angle ψ .

Put x, y for x_1, y_1 , respectively, in the result of § 112, and we get the locus required; viz.,

$$y^2 - 4ax = (a+x)^2 \tan^2 \psi,$$

or

$$y^2 + (x-a)^2 = (x+a)^2 \sec^2 \psi,$$

which represents, as we shall see later, an hyperbola which has the same focus and directrix as the parabola, and whose eccentricity is equal to $\sec \psi$.

The equation may also be written thus,

$$\sqrt{y^2 + (x-a)^2} = (x+a) \sec \psi,$$

which shows it more clearly.

EXERCISES.

1. In $y^2 = 4ax$ find equation of chord through vertex and which is bisected by the diameter $y = a$. *Ans.* $a(y-x) = 0$.

2. The polars of all points on latus rectum meet the axis in the same point $(-a, 0)$.

3. The line joining the focus to the pole of a chord bisects the angle subtended at the focus by the chord.

4. Find the diameter of $y^2 = 12x$, which bisects the chord
 $x - 3y - 1 = 0$.

5. Find the slope of the chords of a diameter of $y^2 = 5x$ which passes through $(1, -5)$.

6. Show that the line $y = m(x+a) + \frac{a}{m}$ touches the parabola

$$y^2 = 4a(x+a).$$

7. p_1 and p_2 are \perp s from the ends of a focal chord on the tangent at vertex. Prove $p_1 \cdot p_2 = a^2$.

8. Find locus of the intersection of

(1) Normals inclined at complementary angles to the axis.

$$\text{Ans. } y^2 = a(x-a).$$

(2) Tangents under same conditions.

$$\text{Ans. Latus rectum.}$$

9. The length of a focal chord of a parabola is L . Show that the product of its segments = $a \cdot L$ [where $y^2 = 4ax$].

10. Show that the locus of the mid-points of focal chords is

$$y^2 = 2a(x - a).$$

11. The locus of the mid-points of normal chords is

$$y^4 - 2ay^2(x - 2a) + 8a^4 = 0.$$

12. Two tangents are drawn to a parabola from a given point. Show that they are bisected by a third tangent parallel to the chord of contact of the first two.

13. Taking the pole at the intersection of axis and directrix, find polar equation of parabola.

14. A straight line is drawn from the intersection of the axis and directrix cutting the parabola, and a focal chord is drawn parallel to it. Prove, the rectangle of the segment of the focal chord is equal to the rectangle of the intercepts of the line made on the parabola.

15. Find locus of center of a \odot which passes through a given point and touches a given line. [Take line and \perp on it from point as axes.]

Ans. A parabola.

16. A point moves so that its distance from a fixed point always equals its distance from a fixed circle. Show that its locus is a conic having the fixed point as a focus. The fixed \odot is called the "direction circle" of the conic.

17. The tangents at the ends of a focal chord of any conic meet in the directrix.

18. Given a diameter of a \odot and a parallel chord. A line is drawn from the right end of diameter to mid-point of chord, and a line from right end of chord to mid-point of diameter. Find locus of their intersection.

Ans. A parabola.

19. F is a focus of a conic, P a point on the corresponding directrix. Prove PF is \perp to the polar of P .

20. Show that the polar of any point on the circle $x^2 + y^2 = ax$ with respect to the circle, $x^2 + y^2 = 2ax$ touches the parabola $y^2 = 4ax$.

116. Equation of the parabola referred to any diameter and the tangent at its extremities as axes.

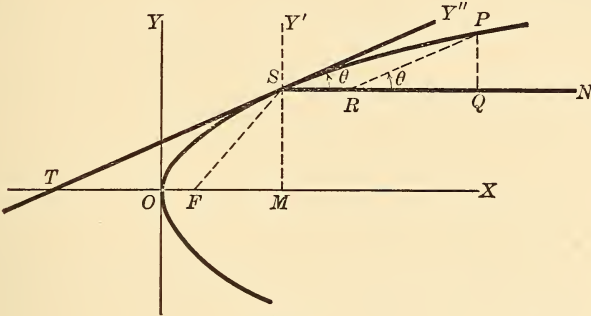

Fig. 112.

SN is the given diameter, ST a tangent at its extremity S. We shall first find the equation referred to SN and SY' perpendicular to it.

$$MS = \frac{2a}{m},$$

and putting this for y in $y^2 = 4ax$,

we get
$$OM = \frac{a}{m^2}.$$

∴ the point of contact S of any tangent

$$\left[y = mx + \frac{a}{m} \right]$$

is $\left(\frac{a}{m^2}, \frac{2a}{m} \right)$, which was also shown in [§ 105].

$$\therefore \left(y + \frac{2a}{m} \right)^2 = 4a \left(x + \frac{a}{m^2} \right);$$

or
$$my^2 + 4ay = 4amx \dots \dots (1)$$

is the equation of the parabola referred to SN and SY'; now let us retain SN as the x -axis and take SY'' as the new y -axis.

Let P be any point on the curve, (x, y) its co-ordinates referred to SN and SY'; (x_1, y_1) its co-ordinates referred to SN and SY''.

$$\text{Then} \quad x = \text{SQ}, \quad x_1 = \text{SR},$$

$$y = \text{PQ}, \quad y_1 = \text{PR}.$$

$$\text{Also,} \quad \text{SQ} = \text{SR} + \text{PR} \cos \theta,$$

$$\text{and} \quad \text{PQ} = \text{PR} \sin \theta,$$

$$\text{or,} \quad x = x_1 + y_1 \cos \theta,$$

$$\text{and} \quad y = y_1 \sin \theta.$$

Hence, substituting these values in (1), and replacing m by $\tan \theta$, we finally obtain

$$y^2 = \frac{4a}{\sin^2 \theta} x$$

as the required equation.

This equation may be simplified by other considerations; thus,

$$\begin{aligned} \text{FS} = a + \text{OM} &= a + \frac{a}{m^2} \\ &= a \cdot \frac{(1 + m^2)}{m^2} \\ &= \frac{a \sec^2 \theta}{\tan^2 \theta} \\ &= \frac{a}{\sin^2 \theta}. \end{aligned}$$

Now let $\text{FS} = a'$,
then the equation becomes

$$y^2 = 4 a' x$$

[referred to any diameter and the tangent at its extremity].

If $\theta = 90^\circ$, this equation becomes $y^2 = 4ax$, which is the equation referred to any diameter and a tangent \perp to it, *i.e.*, to the axis of the curve and the tangent at the vertex.

117. Polar equation of the parabola referred to focus.

P is any point (ρ, θ) on the curve.

Now

$$\begin{aligned} \rho &= FP = PM \\ &= NR = 2a + FR \\ &= 2a + \rho \cos \theta. \end{aligned}$$

$$\therefore \rho = \frac{2a}{1 - \cos \theta}.$$

DISCUSSION. — When

$$\theta = 0, \quad \rho = \infty,$$

\therefore curve does not meet axis

to right of O. When $\theta = \frac{\pi}{2}$, $\cos \theta = 0$, $\therefore \rho = 2a$ [semi-latus rectum].

$$\theta = \pi, \quad \cos \theta = -1, \quad \therefore \rho = a \text{ [FO].}$$

$$\theta = \frac{3}{2}\pi, \quad \cos \theta = 0, \quad \therefore \rho = 2a.$$

$$\theta = 2\pi, \quad \cos \theta = 1, \quad \therefore \rho = \infty \text{ (as it should be).}$$

SUMMARY. — As θ varies from 0 to π , ρ decreases from ∞ to a ; and as θ varies from π to 2π , ρ increases from a to ∞ .

$\cos \theta$ cannot be $> +1$, $\therefore \rho$ is always positive.

If the pole be taken at the vertex, the polar equation is $\rho = \frac{4a \cos \theta}{\sin^2 \theta}$.

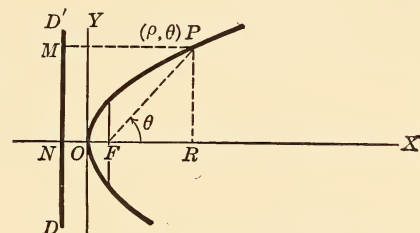

Fig. 113.

EXERCISES.

1. Two tangents to $y^2 = 4ax$ make \angle s ψ_1, ψ_2 , with $x =$ axis.

Find locus of vertex if

(a) $\sin \psi_1 \sin \psi_2 = k$ (a constant).

$$\text{Ans. } x^2 + y^2 - 2ax = \frac{a^2(1 - k^2)}{k^2}.$$

(β) $\tan \psi_1 \tan \psi_2 = k$.

$$\text{Ans. } a - kx = 0.$$

(γ) $\cot \psi_1 \cot \psi_2 = k$.

$$\text{Ans. } ka - y = 0.$$

2. In $y^2 = 4ax$ find the locus of

(a) the mid-points of the ordinates.

$$\text{Ans. } y^2 = ax.$$

(β) the mid-points of chords through the vertex. $\text{Ans. } y^2 = 2ax.$

3. PQ is a double ordinate of a parabola. The line from P to foot of directrix meets curve in P'. Show that P'Q passes through the focus.

4. Two parabolas have a common axis but different vertices. Show that the part of a tangent to the inner, intercepted by the other, is bisected at the point of contact.

5. Find the locus of the intersection of the tangents

$$y = m_1x + \frac{a}{m_1}, \quad y = m_2x + \frac{a}{m_2}, \quad \text{if}$$

$$(\alpha) \quad m_1 \cdot m_2 = k. \quad \text{Ans. } kx - a = 0.$$

$$(\beta) \quad \frac{1}{m_1} + \frac{1}{m_2} = k. \quad \text{Ans. } ka - y = 0.$$

$$(\gamma) \quad \frac{1}{m_1} - \frac{1}{m_2} = k. \quad \text{Ans. } y^2 = 4ax + a^2k^2.$$

6. Three tangents to a parabola, focus F , meet in A, B, C . Now, FA, FB, FC , meet BC, CA, AB , in A', B', C' , respectively. Prove that the \perp s from A, B, C , to the tangents drawn to the curve from A', B', C' , respectively are concurrent.

7. n_1, n_2, n_3 , are the normals, and t_1, t_2 , are the tangents from any point to the parabola $y^2 = 4ax$. Prove, $n_1 \cdot n_2 \cdot n_3 = a \cdot t_1 \cdot t_2$.

8. In the parabola $y^2 = 4ax$, tangents are drawn making with the tangent at vertex a Δ of constant area $= k^2$. Prove that the locus of their intersection is,

$$x^2(y^2 - 4ax) = 4k^4.$$

9. If three normals are drawn from any point to a parabola, show that their feet and the vertex of the parabola are concyclic.

10. Tangents are drawn at points whose ordinates are in the ratio $r : 1$. Find the locus of their intersection.

$$\text{Ans. } ry^2 = ax(1+r)^2 \text{ [where } y^2 = 4ax \text{ is the given curve].}$$

11. Two tangents and their chord of contact form a Δ of constant area $= k^2$. Find locus of their intersection.

12. Find the locus of points from which two \perp normals can be drawn to a parabola.

SUGGESTION. — Show that normals at extremities of a focal chord are \perp to each other. Find locus of their intersection, etc.

EXERCISES ON CHAPTER VII.

1. Tangents are drawn to the parabola $y^2 = 4a_1x$. Find the locus of their poles with respect to the parabola $y^2 = 4a_2x$. *Ans.* $a_1y^2 = 4a_2^2x$.

2. The parabola referred to tangents at ends of latus rectum as axes is where

$$x^{\frac{1}{2}} \pm y^{\frac{1}{2}} = \pm k^{\frac{1}{2}}$$

$$k = 2a\sqrt{2}.$$

3. A circle cuts the parabola

$$y^2 = 4ax \text{ in 4 points, } (x_1, y_1), (x_2, y_2), \dots \text{ etc.}$$

Prove

$$y_1 + y_2 + y_3 + y_4 = 0.$$

SUGGESTION. — Express that the four points are concyclic. Also each lies on $y^2 = 4ax$. Eliminate x , etc.*

4. A variable circle touches a given circle and a given line. Show that the locus of its center is the parabola, focus at center of given \odot , directrix parallel to the given line, and at a distance r from it, where r is radius of the given circle.

5. A secant revolves about a fixed point on the axis of a parabola, and normals to the curve are drawn at the points of intersection with the secant. Find the locus of their intersection.

6. Construct a parabola given the directrix and two of its points.

7. Find the locus of the vertex of a parabola which has a given focus and touches a given straight line.

8. Find the locus of its focus if it has a given vertex and touches a given straight line.

9. Find the locus of a focus of a parabola which touches two given straight lines, one in a fixed point and the other in a variable point.

10. Find the locus of the foci of parabolas which have a common chord and a common tangent parallel to this chord.

11. The sides of a quadrilateral inscribed in a parabola are inclined to the axis at angles $\alpha, \beta, \gamma, \delta$, respectively. Prove :

$$\text{ctn } \alpha + \text{ctn } \gamma = \text{ctn } \beta + \text{ctn } \delta.$$

12. Find the locus of the point of intersection of two parabolas which have a given focus, which touch a given line, and which intersect at a given angle ϕ .

13. Show that the line $x \cos \alpha + y \sin \alpha + \frac{a}{\cos \alpha} = 0$ touches the parabola $y^2 = 4a(x + a)$.

SUGGESTION. — Compare $x \cos \alpha + y \sin \alpha = p$ with the equation of a tangent to the parabola at (x_1, y_1) . What is this equation? Find for what value of p the line will be a tangent, etc.

* See Ex. 97, page 269.

14. If R is mid-point of chord PQ of a parabola, show that the polar of R is parallel to PQ.

15. P, Q, R, are three points on the parabola $y^2 = 4ax$ whose abscissæ are in geometrical progression. Show that the tangents at P and R meet on the ordinate of Q.

16. The locus of the mid-point of that part of a variable tangent to a parabola which is intercepted between two fixed tangents is a straight line.

17. The parabola $y^2 = 4ax$ slides between two rectangular tangents. Show that its focus traces the curve $x^2y^2 = a^2(x^2 + y^2)$.

SUGGESTION. — Let the tangents be $y = mx + \frac{a}{m}$ and $y = -\frac{x}{m} - am$. Find the distances from focus $(a, 0)$ to these tangents. Call these x and y , and eliminate m , obtaining the above equation of the locus referred to the tangents as axes. Show also that the vertex traces the curve

$$x^{\frac{2}{3}}y^{\frac{2}{3}} + x^{\frac{2}{3}}y^{\frac{4}{3}} = a^2.$$

18. The equation of a chord whose middle point is (x_1, y_1) is $(y - y_1)y_1 = 2a(x - x_1)$.

19. The locus of the mid-points of normals is $y^2 = a(x - a)$.

20. The locus of the mid-points of chords through (x_1, y_1) is the parabola,

$$y(y - y_1) = 2a(x - x_1).$$

21. The length of the chord of contact of tangents from (h, k) is

$$\frac{1}{a} \sqrt{(k^2 + 4a^2)(k^2 - 4ah)}$$

22. A circle passes through the focus of a parabola and cuts the curve at angles whose sum is constant. Find the locus of its center.

Ans. A straight line.

23. TP, TQ, are tangents to a parabola; the circle through T, P, Q, meets the parabola again in P' and Q'; and the tangents at P' and Q', meet in T'. Prove TT' passes through the focus.

24. Find the equations of the tangent and normal at the upper end of the latus rectum of the parabola $y^2 = 4ax$.

Ans. $y - x = a$.

$y + x = 3a$.

25. Prove that the product of the latera-recta of two parabolas which can be described through four concyclic points is $\frac{1}{8}(d_1^2 - d_2^2) \sin \phi$ where d_1 and d_2 are the diagonals of the quadrilateral and ϕ the angle between them.

26. The lines joining the origin (vertex) to the points of contact of tangents to a parabola from (x_1, y_1) are represented by the equation

$$x_1 y^2 = 2x(y_1 y - 2ax).$$

27. A \perp Ap from vertex to a tangent at P meets the curve in q . Prove:

$$Ap \cdot Aq = 4a^2.$$

28. The third diagonal of a quadrilateral inscribed in a circle, and circumscribed about a parabola, passes through the focus of the parabola.

29. T and T' are two external points. TP, TQ, T'P', T'Q', are tangents to the parabola. If TT' is bisected by the parabola, show that the six points T, P, Q, T', P', Q', lie on another parabola.

30. Tangents at P, P', meet in T. Prove:

$$\frac{\overline{TP}^2}{\overline{TP'}^2} = \frac{FP}{FP'} \quad (\text{where F is focus}),$$

Also

$$\overline{FT}^2 = FP \cdot FP'.$$

31. A chord PQ [of a parabola], normal at P, meets the axis in M. If y is the ordinate of P, prove

$$\Delta FPQ = \frac{\overline{PM}^4}{4ay}.$$

32. Given the base = $2a$ (of a Δ), altitude = $\frac{b}{2}$, find the locus of its orthocenter.

SUGGESTION. — Take mid-point of base as origin.

$$\text{Ans. } x^2 + by - a^2 = 0 \text{ [a parabola].}$$

33. FL is the \perp from focus on tangent at P. A circle is circumscribed about the Δ FLP. Show that the locus of its center is the parabola

$$y^2 = a(2x - a).$$

CHAPTER VIII

THE ELLIPSE

118. Definition.—If P is a point on the curve, we have $FP = e \cdot PM$, where F is the focus, $PM = \perp$ on DD' [the directrix] and $e < 1$.

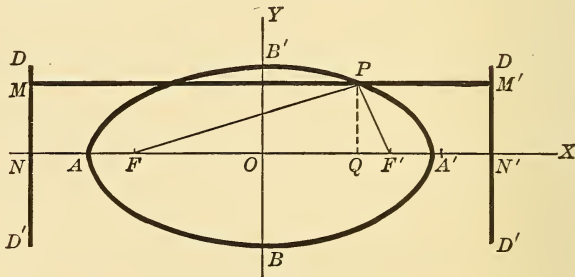

Fig. 114.

119. To find the equation of the ellipse.—Draw $FN \perp$ to the directrix. Now divide FN , internally at A , and externally at A' , in the given ratio $e : 1$.

\therefore by definition A and A' are points on the curve, since

$$FA = e \cdot AN \quad \dots \dots \dots (1)$$

and

$$FA' = e \cdot A'N \quad \dots \dots \dots (2)$$

Now bisect AA' in O , calling the distance AA' $2a$.

Add equations (1) and (2), we get,

$$2 OA = e \cdot 2 ON,$$

or $2a = 2e \cdot ON, \therefore ON = \frac{a}{e} \quad \dots \dots \dots (3)$

and subtract (1) from (2), we get,

$$2 OF = e \cdot 2 OA,$$

$$\therefore OF = ae \quad \dots \dots \dots (4)$$

Now, through O draw $BB' \perp$ to AA' . Take OA' and OB' as axes. The co-ordinates of F are $(-ae, o)$.

Let P be any point (x, y) of the curve.

Then $\overline{FP}^2 = (x + ae)^2 + y^2,$

also $PM = ON + OQ = x + \frac{a}{e}.$

Now, $\overline{FP}^2 = e^2 \cdot \overline{PM}^2$

or, $(x + ae)^2 + y^2 = e^2 \left(x + \frac{a}{e}\right)^2.$

$$\therefore x^2(1 - e^2) + y^2 = a^2(1 - e^2) \quad \dots \dots \dots (5)$$

The intercepts of this on the y -axis are both real and =

$$\pm a \sqrt{1 - e^2} = OB'.$$

Let $OB' = b, \therefore b^2 = a^2(1 - e^2).$

Dividing (5) by its right member $[b^2]$, we get,

$$\frac{x^2}{a^2} + \frac{y^2}{b^2} = 1 \quad \dots \dots \dots (6)$$

which is the required equation of the ellipse.

DISCUSSION. — Equation (5) reveals the following facts about the curve :

(1) It is symmetrical with respect to the x -axis, *i.e.*, the line through the focus and \perp to the directrix. This line $[AA']$ is \therefore called the **major** or **principal axis**.

(2) It is symmetrical with respect to the y -axis, *i.e.*, to $[BB']$ a line \perp to AA' at its middle point O. This line is \therefore called the **minor axis**.

(3) The greatest abscissas are $\pm a$, ordinates $\pm b$, and no real values for x and y beyond these. The ellipse is \therefore a closed curve of one branch lying entirely on the same side of the directrix as the focus.

(4) It is symmetrical with respect to O, which is \therefore called the **center**.

(5) The ellipse has a second focus at F' and a corresponding directrix DD' . F' is point $(ae, 0)$. The equations of the directrices are

$$x \pm \frac{a}{e} = 0.$$

(6) The latus rectum [double ordinate through focus] is equal to $2b\sqrt{1 - e^2} = \frac{2b^2}{a}$ [found by putting $x = ae$ in equation (5) or (6), then solving for y , and multiplying by 2].

NOTE. — If the center is at the point (h, k) , the equation becomes

$$\frac{(x - h)^2}{a^2} + \frac{(y - k)^2}{b^2} = 1 \quad \dots \quad (7)$$

QUERY. — Which ellipses are represented by these equations?

$$\frac{x^2}{b^2} + \frac{y^2}{a^2} = 1 \quad \dots \quad (8)$$

$$\frac{(x - h)^2}{b^2} + \frac{(y - k)^2}{a^2} = 1 \quad \dots \quad (9)$$

NOTE 1. — The distance FF' is generally denoted by $2c$.

NOTE 2. — A and A' are called the vertices of the ellipse.

120. Every equation of the form $Ax^2 + By^2 + 2Gx + 2Fy + C = 0$ represents an ellipse. — We shall illustrate this by a special example; viz.,

$$4x^2 + y^2 - 8x + 2y + 1 = 0.$$

This may be written,

$$4x^2 - 8x + y^2 + 2y + 1 = 0,$$

$$4(x^2 - 2x + 1) + (y^2 + 2y + 1) = 4,$$

or $4(x - 1)^2 + (y + 1)^2 = 4,$

or $\frac{(x - 1)^2}{(1)^2} + \frac{(y + 1)^2}{(2)^2} = 1.$

Comparing this with the type form (7) or (9), we see that it represents an ellipse whose center is at point $(1, -1)$ and whose semi-axes are $a = 2, b = 1$. The ellipse has its major axis parallel to the y -axis.

The other facts about this curve are readily found; viz., the foci are the points $(1, -1 + \sqrt{3})$, $(1, -1, -\sqrt{3})$; the vertices are the points $(1, 1)$, $(1, -3)$; the latus rectum is 1.

The general equation at the beginning of this article may also be shown to represent an ellipse by completing the squares, etc.

121. Internal and external points.—In a manner similar to that used in the parabola, we may show that a point (x, y) is without, on, or within the ellipse

$$\frac{x^2}{a^2} + \frac{y^2}{b^2} = 1,$$

according as $\frac{x^2}{a^2} + \frac{y^2}{b^2} - 1 >, =, \text{ or } < 0$.

122. The squares of any two ordinates are to each other as the products of the segments into which they divide the major axis.—Let (x_1, y_1) and (x_2, y_2) be any two points on the ellipse. Then,

$$y_1^2 = \frac{b^2}{a^2}(a^2 - x_1^2), \quad y_2^2 = \frac{b^2}{a^2}(a^2 - x_2^2).$$

$$\therefore y_1^2 : y_2^2 :: (a - x_1)(a + x_1) : (a - x_2)(a + x_2). \quad \therefore, \text{ etc.}$$

123. The Latus Rectum is a Third Proportional to the Major and Minor Axes.—The latus rectum $= \frac{2b^2}{a} = \frac{4b^2}{2a}$.

[Let l be the latus rectum.]

$$\therefore 2a : 2b :: 2b : l. \quad \therefore, \text{ etc.}$$

124. The sum of the focal distances of any point of an ellipse is constant and equal to $2a$.—In the figure of § 116, $FP = e \cdot PM = e \cdot QN = e(ON + OQ) = e\left(\frac{a}{e} + x\right)$.

$$\therefore FP = a + ex.$$

Also, $F'P = e \cdot PM' = e \cdot QN' = e \cdot (ON' - OQ)$.

$$\therefore F'P = a - ex.$$

$$\therefore PF + PF' = 2a.$$

Hence, the ellipse is the locus of a point which moves so that the sum of its distances from two fixed points [the foci] is constant and equal to $2a$.

125. Construction of the ellipse when foci and the constant sum $2a$ are given. — This is based on § 123.

(1) *By points.*

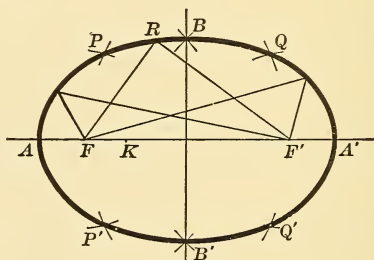

Fig. 115.

Bisect FF' in O , and take $OA = OA' = a$. Then A and A' are points on the curve. [Why?] Now between F and F' take any point K . With F as center and AK as radius, describe arcs; with F' as center and $A'K$ as radius, describe arcs intersecting the former in P and P' . By interchanging radii, Q and Q' are found. These all lie on the curve because the sum of the focal distances of each is $2a$. After finding enough points we join them by a smooth curve.

(2) *Mechanically.* Fix pins at F and F' and join them by a string of length $2a$. A pencil point P moved so as to keep the string stretched will trace the ellipse; for in all positions of P , we have $PF + PF' = 2a$.

EXERCISES.

1. A line AB of given length moves with its ends in two rectangular axes OX, OY. Find the locus of a fixed point P on the line.

$$\text{Put } PB = a, \quad PA = b, \quad \angle OAB = \theta.$$

Draw $PN \perp OX$. Then the co-ordinates of P are (x, y) ON, PN.

$$\text{Then} \quad \sin \theta = \frac{PN}{PA} = \frac{y}{b}, \quad \cos \theta = \frac{x}{a}.$$

Squaring and adding,

$$\frac{x^2}{a^2} + \frac{y^2}{b^2} = 1.$$

NOTE. This principle is utilized in an instrument for describing the ellipse mechanically.

2. If OP and OQ are two semi-diameters \perp to each other, prove,

$$\frac{1}{OP^2} + \frac{1}{OQ^2} = \frac{1}{a^2} + \frac{1}{b^2}.$$

3. Find equation of ellipse, focus $(1, 2)$, directrix $2x - y - 1 = 0$, eccentricity $= \frac{1}{3}$.

4. Is the point $(2, 3)$ inside or outside the ellipse $x^2 + 4y^2 = 16$?

5. Find eccentricity, length of latus rectum, co-ordinates of foci in the ellipses.

$$(1) \quad 25x^2 + 9y^2 = 225.$$

$$(2) \quad 9x^2 + 4y^2 = 36.$$

$$\text{Ans. } \frac{1}{3}\sqrt{5}, 2\frac{2}{3}, (0, \pm\sqrt{5}).$$

$$(3) \quad 4(x-2)^2 + 9(y-3)^2 = 1.$$

$$(4) \quad 2x^2 + y^2 = 3x. \quad \text{Ans. } \frac{1}{\sqrt{2}} = \text{eccentricity}; \quad \text{foci, } (\frac{3}{4}, \pm\frac{3}{4}).$$

$$(5) \quad x^2 + 9y^2 = 81.$$

6. P, Q, R, are three points on the ellipse whose abscissas are in arithmetical progression. Show that OP, OQ, OR, are also in arithmetical progression.

7. P is any point on the ellipse, and PB, PB', meet AA' in p, q. Prove $Op \cdot Oq = a^2$.

8. Equation of the ellipse with A as origin is $y^2 = \frac{b^2}{a^2}(2ax - x^2)$.

9. Show by Ex 8 that locus of mid-points of chords of the ellipse, passing through A, is another ellipse.

10. Given base of $\triangle ABC$ and $\tan \frac{1}{2} A \cdot \tan \frac{1}{2} B$, find locus of vertex C.

$$\tan \frac{1}{2} A \cdot \tan \frac{1}{2} B = \frac{S - a}{S} \quad \therefore S \text{ [sum of sides] is given.}$$

Ans. Ellipse, foci A and B [ends of base].

11. Find also the locus of center of its inscribed \odot .

Ans. Ellipse, major axis = AB.

126. NOTE 1. — We may show that the circle is a special case of the ellipse, thus: If, in the equation $\frac{x^2}{a^2} + \frac{y^2}{b^2} = 1$, a remain constant, while b increases, then c decreases [for $c = \sqrt{a^2 - b^2}$],

$$\therefore e \text{ decreases, for } \left[c = ae, \therefore e = \frac{c}{a} \right].$$

\therefore the foci approach the center, and the ellipse approaches a circle.

If $b = a, c = 0, \therefore e = 0, \therefore$ foci coincide with the center, and the equation of the ellipse becomes $x^2 + y^2 = a^2$, a circle, radius a .

If b decreases and approaches $0, c$ approaches a , and finally when $b = 0, c = a, e = 1$. Hence the ellipse becomes thinner gradually, and finally coincides with the x -axis, for its equation becomes $y = 0$.

NOTE 2. — To find the polar equation of the ellipse, with center as pole, we put $y = \rho \sin \theta, x = \rho \cos \theta$, and obtain

$$\begin{aligned} \frac{\rho^2 \cos^2 \theta}{a^2} + \frac{\rho^2 \sin^2 \theta}{b^2} &= 1, \\ \text{or, } \frac{1}{\rho^2} &= \frac{\cos^2 \theta}{a^2} + \frac{\sin^2 \theta}{b^2}. \\ \therefore \rho^2 &= \frac{a^2 b^2}{a^2 \sin^2 \theta + b^2 \cos^2 \theta} \\ &= \frac{a^2 b^2}{b^2 + (a^2 - b^2) \sin^2 \theta}. \end{aligned}$$

This denominator is least [*i. e.*, ρ is greatest] when $\theta = 0; \therefore \rho = a$.
 \therefore the ellipse is a closed curve, which was also shown before.

127. The tangent at (x_1, y_1) . — The equation of any chord is

$$\frac{y - y_1}{x - x_1} = \frac{y_1 - y_2}{x_1 - x_2} \quad \dots \dots \dots (1)$$

Also

$$\frac{x_1^2}{a^2} + \frac{y_1^2}{b^2} = 1 \quad \dots \dots \dots (2)$$

$$\frac{x_2^2}{a^2} + \frac{y_2^2}{b^2} = 1 \quad \dots \dots \dots (3)$$

∴ by subtraction

$$\frac{(x_1 - x_2)(x_1 + x_2)}{a^2} + \frac{(y_1 - y_2)(y_1 + y_2)}{b^2} = 0.$$

∴ (1) becomes,

$$\frac{y - y_1}{x - x_1} = -\frac{b^2}{a^2} \frac{x_1 + x_2}{y_1 + y_2} \dots \dots \dots (4)$$

Now put $x_2 = x_1, y_2 = y_1$, then (4) becomes

$$\frac{y - y_1}{x - x_1} = -\frac{b^2 x_1}{a^2 y_1} \dots \dots \dots (5)$$

or, $a^2 y y_1 + b^2 x x_1 = a^2 y_1^2 + b^2 x_1^2,$

or, $\frac{x x_1}{a^2} + \frac{y y_1}{b^2} = \left[\frac{x_1^2}{a^2} + \frac{y_1^2}{b^2} \right] = 1.$

$$\therefore \frac{x x_1}{a^2} + \frac{y y_1}{b^2} = 1$$

is the required equation.

The normal is $(y - y_1) = \frac{a^2 y_1}{b^2 x_1} (x - x_1).$

The subtangent and subnormal are found by putting $y = 0$ in equations of the tangent and normal; viz.,

subtangent $= \frac{x_1^2 - a^2}{x_1}.$

subnormal $= -\frac{b^2}{a^2} x_1.$

NOTE. — That the subtangent is a function of the abscissa and a .

128. Equation of tangent in terms of slope. — The abscissas of the points of intersection of the line

$$y = mx + c \dots \dots \dots (1)$$

with $\frac{x^2}{a^2} + \frac{y^2}{b^2} = 1 \dots \dots \dots (2)$

are determined by the equation

$$\frac{x^2}{a^2} + \frac{(mx + c)^2}{b^2} = 1 \dots \dots \dots (3)$$

The roots are equal; *i.e.*, (1) is a tangent to (2) if in the equation

$$(a^2 m^2 + b^2) x^2 + 2 mc a^2 x + a^2 (c^2 - b^2) = 0,$$

which is the equivalent of (3), we have

$$(a^2 m^2 + b^2) \cdot a^2 (c^2 - b^2) = m^2 c^2 a^4,$$

or,

$$c^2 = a^2 m^2 + b^2.$$

$$\therefore c = \pm \sqrt{a^2 m^2 + b^2}.$$

Hence, there may be two tangents of given slope m to the ellipse; *viz.*,

$$y = mx \pm \sqrt{m^2 a^2 + b^2} (4)$$

The point of contact of this tangent may be easily found by comparing the equations

$$y = mx \pm \sqrt{m^2 a^2 + b^2}$$

and

$$\frac{xx_1}{a^2} + \frac{yy_1}{b^2} = 1,$$

as in the case of the parabola, and finding x_1, y_1 in terms of a, b , and m .

129. Tangents from a given point. — If (4) passes through (x_1, y_1) we have

$$y_1 = mx_1 + \sqrt{m^2 a^2 + b^2},$$

whence
$$m = \frac{x_1 y_1 \pm \sqrt{b^2 x_1^2 + a^2 y_1^2 - a^2 b^2}}{x_1^2 - a^2}.$$

\therefore There are two real, two coincident, or no tangents, according as $b^2 x_1^2 + a^2 y_1^2 - a^2 b^2 >, =, \text{ or } < 0$; *i.e.*, according as (x_1, y_1) is without, on, or within the ellipse.

EXERCISES.

1. A Δ is circumscribed about an ellipse. Show that the products of the alternate segments of the sides made by the points of contact are equal.

2. In a given rhombus to inscribe an ellipse of given eccentricity.

3. The tangent and normal to the ellipse at the end of the latus rectum [first quadrant] are

$$y + ex - a = 0, \quad ey - x + ae^3 = 0.$$

4. For what value of k will the line $x + y = k$ touch the ellipse

$$\frac{x^2}{a^2} + \frac{y^2}{b^2} = 1 ?$$

5. A square is inscribed in an ellipse. Find length of its side.

$$\text{Ans. } \frac{2ab}{\sqrt{a^2 + b^2}}$$

6. Tangents to the ellipse from (h, k) make an angle ϕ .

Prove, $\{h^2 + k^2 - a^2 - b^2\} \tan \phi = 2 \sqrt{b^2 h^2 + a^2 k^2 - a^2 b^2}$.

7. P is any point on the ellipse. Show that the locus of the center of the circle inscribed in $\triangle FPF'$ [F, F' are foci] is the ellipse

$$(1 - e) x^2 + (1 + e) y^2 = e^2 a^2 (1 - e).$$

8. The locus of the mid-point of a normal is the ellipse

$$4 b^2 x^2 + 4 a^2 y^2 (1 + e^2) = a^2 b^2 (1 + e^2)^2.$$

NOTE. — Normal here means length of normal intercepted by major axis.

9. The locus of the mid-points of chords of the ellipse which touch the concentric circle $x^2 + y^2 = c^2$ is the curve

$$\left\{ \frac{x^2}{a^2} + \frac{y^2}{b^2} \right\}^2 = c^2 \left\{ \frac{x^2}{a^4} + \frac{y^2}{b^4} \right\}.$$

10. A \triangle inscribed in an ellipse has a fixed centroid. Show that its orthocenter traces an ellipse.

130. The auxiliary circle. The principle of the elliptic compass.

The circle described with the center of the ellipse as a center and a radius OA is called the major **auxiliary** circle. That with a radius OB, the minor auxiliary circle. We shall consider only the former for the present.

Let P (x, y) be any point on the ellipse, whose ordinate PN meets the auxiliary circle in Q. Now from the equation of the ellipse we get

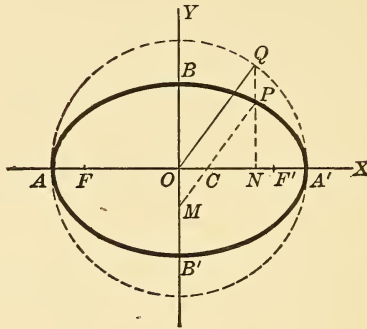

Fig. 116.

$$y = \frac{b}{a} \sqrt{a^2 - x^2}$$

or,
$$PN = \frac{b}{a} \sqrt{OQ^2 - ON^2} = \frac{b}{a} \cdot QN.$$

$$\therefore PN : QN :: b : a.$$

Hence, the ordinates of the ellipse and auxiliary circle at corresponding points are in the constant ratio of $b : a$.

Now draw $PCM \parallel$ to OQ and cutting the axes in C and M .

Then $PM = OQ = a$,

and by similar Δ s, $PC : OQ :: PN : QN :: b : a$.

$\therefore PC = b$. Hence, if PM be a ruler having pins at C and M which may move along the ruler at will, and if AA' , BB' , are grooves in which these pins run, a pencil point at P will trace an ellipse whose semi-axes are PM and PC , or a and b . Such an instrument is called an elliptic compass.*

131. Eccentric angle. Chord joining two points.—The angle QOA' [Fig. 116, § 130] is called the **eccentric angle** of the point P . The co-ordinates of P may be written $x = a \cos$

* See Fig. 173, end of book.

ψ , $y = b \sin \psi$, where ψ is its eccentric angle ; for these values evidently satisfy the equation

$$\frac{x^2}{a^2} + \frac{y^2}{b^2} = 1.$$

Again, two points whose eccentric angles are ψ and ψ' respectively, may be written $(a \cos \psi, b \sin \psi)$, and $(a \cos \psi', b \sin \psi')$; and the chord joining them is evidently

$$\begin{vmatrix} x & y & 1 \\ a \cos \psi & b \sin \psi & 1 \\ a \cos \psi' & b \sin \psi' & 1 \end{vmatrix} = 0,$$

or $bx (\sin \psi - \sin \psi') - ay (\cos \psi - \cos \psi') = ab \sin (\psi - \psi')$,
 or $2 bx \sin \left(\frac{\psi - \psi'}{2}\right) \cos \left(\frac{\psi + \psi'}{2}\right) + 2 ay \sin \left(\frac{\psi + \psi'}{2}\right) \sin \left(\frac{\psi - \psi'}{2}\right)$
 $= 2 ab \sin \left(\frac{\psi - \psi'}{2}\right) \cos \left(\frac{\psi - \psi'}{2}\right).$

Divide by $2 ab \sin \left(\frac{\psi - \psi'}{2}\right)$ and we get as a final result,

$$\frac{x}{a} \cos \left[\frac{\psi + \psi'}{2}\right] + \frac{y}{b} \sin \left[\frac{\psi + \psi'}{2}\right] = \cos \left[\frac{\psi - \psi'}{2}\right],$$

which is the equation of the chord joining the two given points.

NOTE. — We shall find that by using the eccentric angle, we obtain symmetrical results which shorten the work very much.

132. Equations of tangent and normal at the point whose eccentric angle is ψ . — If the chord in § 131 revolve about one of the two points given, it will become a tangent at that point, and ultimately $\psi' = \psi$. Hence, to find the equation of the tangent, we put $\psi' = \psi$ in the result of § 131, and obtain

$$\frac{x}{a} \cos \psi + \frac{y}{b} \sin \psi = 1 (1)$$

The normal is \perp to it at the point $(a \cos \psi, b \sin \psi)$; its equation is \therefore found to be

$$\frac{ax}{\cos \psi} - \frac{by}{\sin \psi} = a^2 - b^2 \quad \dots \quad (2)$$

The tangent at the vertex $(a, 0)$ is found thus: the eccentric angle at that point is $\psi = 0$, \therefore (1) becomes

$$\frac{x}{a} \cos \psi = 1, \quad \text{or,} \quad x = a.$$

The normal,

$$ax \sin \psi - by \cos \psi = \sin \psi \cos \psi (a^2 - b^2),$$

becomes, $-by \cos \psi = 0, by = 0, \therefore y = 0.$

These results are also obtained by putting $(a, 0)$ for (x_1, y_1)

in the equation $\frac{xx_1}{a^2} + \frac{yy_1}{b^2} = 1.*$

133. Locus of the foot of a \perp from the focus to a tangent. — Any tangent is

$$y = mx + \sqrt{m^2 a^2 + b^2} \quad \dots \quad (1)$$

The \perp on it from the focus $(ae, 0)$ is

$$x + my = ae \quad \dots \quad (2)$$

Squaring and adding (1) and (2), we get,

$$\begin{aligned} (1 + m^2)(x^2 + y^2) &= a^2 m^2 + b^2 + a^2 e^2 \\ &= a^2(1 + m^2). \end{aligned}$$

$\therefore x^2 + y^2 = a^2$ is the required locus [the auxiliary circle].

EXERCISES ON ECCENTRIC ANGLE.

1. The locus of the intersection of tangents to an ellipse at points whose eccentric angles differ by a constant 2ψ is the ellipse

$$\frac{x^2}{a^2} + \frac{y^2}{b^2} = \sec^2 \psi.$$

* Equation (1) above is also obtained from this equation by putting $x_1 = a \cos \psi, y_1 = b \sin \psi.$

2. The point of intersection of the tangents

$$\left. \begin{aligned} \frac{x}{a} \cos \alpha + \frac{y}{b} \sin \alpha &= 1, \\ x \cos \beta + \frac{y}{b} \sin \beta &= 1, \end{aligned} \right\} \begin{array}{l} \text{at points whose} \\ \text{eccentric angles} \\ \text{are } \alpha \text{ and } \beta, \end{array}$$

is
$$x = a \left\{ \frac{\cos \left(\frac{\alpha + \beta}{2} \right)}{\cos \left(\frac{\alpha - \beta}{2} \right)} \right\}, \quad y = b \left\{ \frac{\sin \left(\frac{\alpha + \beta}{2} \right)}{\cos \left(\frac{\alpha - \beta}{2} \right)} \right\}.$$

3. P is a point on the ellipse, eccentric angle = α . Show that the equations of $\Delta'P$ and ΔP are

$$\begin{aligned} \frac{x}{a} \cos \frac{\alpha}{2} + \frac{y}{b} \sin \frac{\alpha}{2} &= \cos \frac{\alpha}{2}, \\ \frac{y}{b} \cos \frac{\alpha}{2} - \frac{x}{a} \sin \frac{\alpha}{2} &= \sin \frac{\alpha}{2}. \end{aligned}$$

SUGGESTION. — Eccentric \angle of Δ' is 0, of Δ is π .

4. α and β are the eccentric angles of the extremities of a focal chord.

Prove
$$\tan \frac{\alpha}{2} \cdot \tan \frac{\beta}{2} = \frac{e - 1}{e + 1}.$$

5. ψ_1 and ψ_2 are the eccentric angles of the points of contact of tangents from (h, k) .

Prove
$$\tan \left\{ \frac{\psi_1 - \psi_2}{2} \right\} = \sqrt{\frac{h^2}{a^2} + \frac{k^2}{b^2} - 1}.$$

6. A chord is drawn joining the points whose eccentric angles are α and β . Show that its length is $2\delta \sin \left(\frac{\alpha - \beta}{2} \right)$ where δ is the parallel semi-diameter.

7. The vertices of a Δ are three points on the ellipse whose eccentric angles are α, β, γ . Show that its area is

$$2ab \cdot \sin \left[\frac{\alpha - \beta}{2} \right] \sin \left[\frac{\beta - \gamma}{2} \right] \sin \left[\frac{\gamma - \alpha}{2} \right].$$

8. The area of the Δ formed by tangents at the points whose eccentric angles are α, β, γ , is

$$ab \cdot \tan \frac{1}{2}(\alpha - \beta) \tan \frac{1}{2}(\beta - \gamma) \tan \frac{1}{2}(\gamma - \alpha).$$

9. Two chords of the ellipse meet the major-axis at points equidistant from the center. The eccentric angles of their extremities are $\alpha, \beta, \gamma, \delta$.

Prove
$$\tan \frac{\alpha}{2} \tan \frac{\beta}{2} \tan \frac{\gamma}{2} \tan \frac{\delta}{2} = 1.$$

10. M is foot of the \perp from center on a tangent at P. From M a tangent is drawn, touching the ellipse in Q. The eccentric angles of P and Q are ψ and ϕ respectively.

Prove
$$\frac{b^2}{a^2} = \frac{\tan \psi}{\tan \left(\frac{\psi + \phi}{2} \right)}.$$

11. P and P' are two points on the ellipse, whose eccentric angles are ϕ_1 and ϕ_2 . The circle describes on PP' as a diameter meets the curve again in Q and Q'. Show that the equation of QQ' is

$$\frac{x}{a} \cos \left(\frac{\phi_1 + \phi_2}{2} \right) - \frac{y}{b} \sin \left(\frac{\phi_1 + \phi_2}{2} \right) = \left(\frac{a^2 + b^2}{a^2 - b^2} \right) \cos \left(\frac{\phi_1 - \phi_2}{2} \right).$$

134. Locus of the intersection of two tangents \perp to each other. — Let one of the tangents be

$$y - mx = \sqrt{m^2 a^2 + b^2} \dots \dots (1)$$

Then the other is $y - m_1 x = \sqrt{m_1^2 a^2 + b^2}$,

but
$$m_1 = -\frac{1}{m}.$$

\therefore its equation is, $my + x = \sqrt{m^2 b^2 + a^2} \dots \dots (2)$

Squaring and adding (1) and (2), we obtain

$$(1 + m^2) x^2 + (1 + m^2) y^2 = (1 + m^2) (a^2 + b^2).$$

$$\therefore x^2 + y^2 = a^2 + b^2$$

is the required locus. It is called the **director circle**. Another method: If the line $x \cos a + y \sin a = p$ is a tangent to the ellipse, its coefficients and those of the equation

$$\frac{xx_1}{a^2} + \frac{yy_1}{b^2} = 1$$

must be proportional.

$$\therefore \frac{x_1}{a^2 \cos a} = \frac{y_1}{b^2 \sin a} = \frac{1}{p},$$

or
$$\frac{\left[\frac{x_1}{a} \right]}{a \cos a} = \frac{\left[\frac{y_1}{b} \right]}{b \sin a} = \frac{1}{p} = \frac{\left[\frac{x_1}{a} \right] + \left[\frac{y_1}{b} \right]}{a \cos a + b \sin a}.$$

But since
$$\left[\frac{x_1}{a}\right]^2 + \left[\frac{y_1}{b}\right]^2 = 1,$$

$$\therefore p^2 = a^2 \cos^2 a + b^2 \sin^2 a.$$

$$\therefore p = \sqrt{a^2 \cos^2 a + b^2 \sin^2 a}.$$

\therefore the line $x \cos a + y \sin a = \sqrt{a^2 \cos^2 a + b^2 \sin^2 a}$

is a tangent to the ellipse. Now put $\frac{\pi}{2} + a$ for a , and we obtain,

$$-x \sin a + y \cos a = \sqrt{a^2 \sin^2 a + b^2 \cos^2 a}$$

for the equation of the tangent \perp to the first.

Squaring and adding both, a is eliminated, and we obtain,

$$x^2 + y^2 = a^2 + b^2, \text{ as before.}$$

135. Properties of the ellipse. — (1) Tangents drawn at corresponding points, to any number of ellipses [circle in-

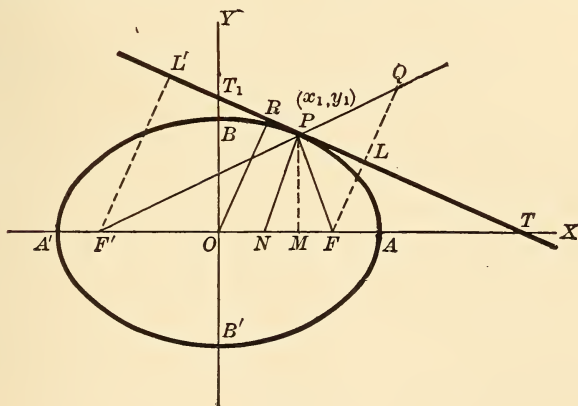

Fig. 117.

cluded] which have a common major axis, meet on that axis produced. For the sub-tangent

$$\left[= \frac{x_1^2 - a^2}{x_1} \right]$$

is constant for all.

(2) The normal at any point bisects the angle between the focal radii of that point.

The tangent at P is $\frac{xx_1}{a^2} + \frac{yy_1}{b^2} = 1$;

and putting $y = 0$,

we get $xx_1 = a^2$, i.e., $OM \cdot OT = a^2$.

Similarly, $yy_1 = b^2$. i.e., $PM \cdot OT_1 = b^2$;

and putting $y = 0$ in the equation of the normal, we get

$$x = x_1 \left(1 - \frac{b^2}{a^2}\right) = e^2 x_1, \quad \text{i.e., } ON = e^2 \cdot OM.$$

$$\therefore F'N = ae + e^2 x_1 = e \cdot F'P,$$

and $FN = ae - e^2 x_1 = e \cdot FP$.

$$\therefore F'N : FN :: F'P : FP.$$

\therefore PN bisects $\angle F'PF$ [by Plane Geometry].

\therefore , etc.

(3) If OR is the \perp from origin on the tangent, then $PN \cdot OR = b^2$.

The distance from P (x_1, y_1) to N $(e^2 x_1, 0)$ is

$$\begin{aligned} \sqrt{(x_1 - e^2 x_1)^2 + y_1^2} &= \sqrt{x_1^2 \frac{b^4}{a^4} + y_1^2} \\ &= b^2 \sqrt{\frac{x_1^2}{a^4} + \frac{y_1^2}{b^4}}, \end{aligned}$$

and the \perp from origin to the tangent = OR is equal to

$$\frac{1}{\sqrt{\frac{x_1^2}{a^4} + \frac{y_1^2}{b^4}}}.$$

$$\therefore PN \cdot OR = b^2. \quad \therefore, \text{ etc.}$$

(4) If $F'L'$ and FL are \perp s on the tangent from the foci, then, $F'L' \cdot FL = b^2$ [proof by student].

(5) L' and L lie on the auxiliary circle. Let FL meet $F'P$ produced in Q . Then \triangle s PLF and PLQ are equal. [Why?]

$$\therefore LF = LQ, \quad PF = PQ. \quad \therefore F'Q = 2a.$$

$$\therefore FQ = 2FL, \quad \text{and} \quad F'F = 2OF.$$

$\therefore OL$ is parallel to $F'Q$, and $= \frac{1}{2} F'Q = a$.

Similarly, $OL' = a$.

$\therefore L'$ and L are at a distance a from the center.

$\therefore L'$ and L lie on the auxiliary circle.

NOTE. — For variety, the student should prove the various exercises both analytically and geometrically when possible. The analytical proof will generally be found more elegant and more expeditious.

(6) The area of an ellipse is πab .

Describe the auxiliary circle.

Then,

$$\frac{\text{rectangle } MPRN}{\text{rectangle } MQSN} = \frac{MP}{MQ} = \frac{b}{a}.$$

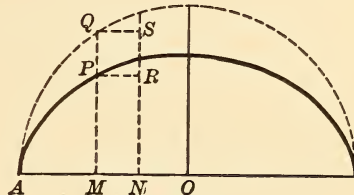

Hence, the sums of any number of rectangles with equal bases will be to each other as $b : a$.

\therefore the elliptic and circular quadrants have this ratio, by the theory of limits.

$$\therefore \frac{\text{ellipse}}{\text{circle}} = \frac{b}{a}.$$

But circle $= \pi a^2$. \therefore ellipse [area] $= \pi ab$.

136. Equation of diameter of ellipse.

Let any chord of a parallel system be $y = mx + c$, and $(x_1, y_1), (x_2, y_2)$, its extremities.

Then the co-ordinates of its mid-point are found from these equations,

$$2x = x_1 + x_2,$$

$$2y = y_1 + y_2.$$

$$\text{Also, } \therefore m = \frac{y_1 - y_2}{x_1 - x_2} = -\frac{b^2}{a^2} \cdot \frac{x_1 + x_2}{y_1 + y_2}.$$

$$\therefore m = -\frac{b^2 x}{a^2 y}.$$

$$\therefore y = -\frac{b^2 x}{a^2 m}$$

is the equation of a diameter, a straight line through the center.

137. Conjugate diameters.— If in the preceding article we write the equation of the diameter in the form

$$y = m_1 x, \text{ then } m_1 = -\frac{b^2}{a^2 m}.$$

$$\therefore mm_1 = -\frac{b^2}{a^2}.$$

This relation is evidently the condition that the diameter $y = m_1 x$ shall bisect all chords parallel to the diameter $y = mx$. It is also the condition that the latter shall bisect the chords parallel to the former.

Hence, if one diameter bisects all chords parallel to another, the second bisects the chords parallel to the first. Two such diameters are called **conjugate diameters**.

The condition that two diameters be conjugate is again,

$$mm_1 = -\frac{b^2}{a^2}.$$

This condition shows that the slopes of two conjugate diameters have opposite signs, \therefore two conjugate diameters of an ellipse lie on opposite sides of the minor axis.

As an exercise, let the student prove, both geometrically and analytically, that the tangents at the extremities of any diameter are parallel to the chords of that diameter. Also let the student construct a tangent and normal to an ellipse at a given point.

EXERCISES.

1. Two focal chords are drawn at right angles in an ellipse. If r_1 , r_2 , are their lengths, prove

$$\frac{1}{r_1} + \frac{1}{r_2} = \text{a constant} = \frac{a(2 - e^2)}{2b^2}.$$

2. A tangent at the end of the latus rectum of a certain ellipse passes through a point of trisection of the minor axis. Prove that the eccentricity of the ellipse is determined by the equation

$$9e^4 + e^2 - 1 = 0.$$

3. An ellipse slides between two rectangular axes. Show that the locus of its center is the circle

$$x^2 + y^2 = a^2 + b^2.$$

Take two \perp tangents [in slope form] as axes. Put their distances from center (o, o) equal to x and y respectively. Eliminate m , etc.

4. The two tangents from (h, k) to the ellipse are represented by the equation

$$\left[\frac{h^2}{a^2} + \frac{k^2}{b^2} - 1 \right] \left[\frac{x^2}{a^2} + \frac{y^2}{b^2} - 1 \right] = \left[\frac{hx}{a^2} + \frac{ky}{b^2} - 1 \right]^2.$$

5. The locus of the foot of a \perp from the center of an ellipse to a tangent is the curve

$$(x^2 + y^2)^2 = a^2x^2 + b^2y^2.$$

6. A tangent meets the director circle $[x^2 + y^2 = a^2 + b^2]$ in M and N. Prove OM and ON are conjugate diameters of the ellipse [where O is center].

7. Each of the two tangents drawn to an ellipse from a point on the directrix subtends a right angle at the focus.

8. The circle on any focal distance as a diameter touches the major auxiliary circle.

9. From the center of an ellipse two radii vectors are drawn \perp to each other, and tangents are drawn to the ellipse at their extremities. The locus of the intersection of these tangents is the ellipse

$$\frac{x^2}{a^4} + \frac{y^2}{b^4} = \frac{1}{a^2} + \frac{1}{b^2}.$$

10. Locus of the intersection of tangents at the ends of two conjugate diameters is the ellipse

$$\frac{x^2}{a^2} + \frac{y^2}{b^2} = 2.$$

11. Find a point on the ellipse at which the tangent makes equal angles with the axes.

$$Ans. \left(\frac{a^2}{\sqrt{a^2 + b^2}}, \frac{b^2}{\sqrt{a^2 + b^2}} \right).$$

Also, so that the tangent makes intercepts proportional to the axes.

$$Ans. \left(\frac{a}{\sqrt{2}}, \frac{b}{\sqrt{2}} \right).$$

12. The tangents to an ellipse from any external point make equal angles with the lines drawn to the foci from that point.

13. A parabola, described with any point on an ellipse as focus, and the tangent at the corresponding point to the major auxiliary circle as a directrix, passes through the foci of the ellipse.

14. The \perp from focus on a tangent, and the line joining the center to the point of contact, meet on the corresponding directrix.

15. P, Q, R, are three points on an ellipse; p, q, r , are the three corresponding points on the auxiliary circle [major].

Prove $\Delta PQR : \Delta pqr :: b : a.$

16. Find the locus of a point such that tangents being drawn from it to an ellipse, the area of the Δ formed by these with major axis = Δ which they form with minor axis.

Ans. The equi-conjugate diameters.

17. Any two conjugate diameters subtend angles θ_1, θ_2 , at a fixed point on the ellipse.

Prove $\cot^2 \theta_1 + \cot^2 \theta_2 = a \text{ constant.}$

18. PQ is a focal chord, and R is the intersection of the tangent at P and the normal at Q. Show that QR is bisected by the minor axis.

19. P is any point (x, y) on the ellipse. Show that the *ctn* of angle APA' varies as y .

20. A line through O parallel to the tangent at P meets the focal radii of P in M and N.

Prove $PM = PN = a$.

21. P and Q are two points on the ellipse the sum of whose eccentric $\angle s = 2\alpha$ [a constant]. Find the locus of intersection of tangents at P and Q.

Ans. [Straight line] $ay - bx \tan \alpha = 0$.

22. The normal at P meets the axes in L and L'.

Prove $PL \cdot PL' = PF \cdot PF'$ [where F, F' are the foci].

23. P is any point on the ellipse. Show that the locus of the intersection of AP with the \perp to A'P through A' is the straight line.

$$x = \frac{a(a^2 + b^2)}{(a^2 - b^2)}.$$

24. OP, OD, are semi-conjugate diameters.

Prove $FP \cdot F'P = \overline{OD}^2$.

Show also that the locus of the mid-point of PD is

$$\frac{x^2}{a^2} + \frac{y^2}{b^2} = \frac{1}{2}$$

25. The locus of the mid-points of chords through (h, k) [a fixed point] is the ellipse

$$\frac{x^2}{a^2} + \frac{y^2}{b^2} = \frac{hx}{a^2} + \frac{ky}{b^2}.$$

26. The normal at P meets the major axis in M and the diameter conjugate to OP, in N.

Prove $PM \cdot PN = b^2$.

27. The equation of the chord whose mid-point is (h, k) is

$$\frac{h}{a^2}(x - h) + \frac{k}{b^2}(y - k) = 0.$$

28. P and D are the ends of conjugate diameters. Prove that the sum of the squares of the $\perp s$ from P and D on a fixed diameter is constant.

29. N is any point on the auxiliary circle [major]. A'N, AN, meet the ellipse in M' and M.

Prove $\frac{AN}{AM} + \frac{A'N}{A'M'} = \frac{a^2 + b^2}{b^2}$.

30. Show that the normals at the ends of a focal chord intersect on a parallel to the major axis through the middle point of the chord.

31. From any point P on the ellipse $\perp s$ are dropped on the equi-conjugate diameters. Show that the normal at P bisects the line joining their feet.

32. In an ellipse chords are drawn of a constant length = 2λ . Show that the locus of their mid-points is

$$\frac{x^2}{a^2} + \frac{y^2}{b^2} + \frac{\lambda^2 [a^2 y^2 + b^2 x^2]}{a^4 y^2 + b^4 x^2} - 1 = 0.$$

33. P and D are the ends of conjugate diameters, and normals at these points meet in M.

Prove

$$OM \perp PD.$$

34. OP, OD, and OP', OD', are pairs of conjugate semi-diameters. Prove

$$\triangle POP' = \triangle DOD'.$$

35. P is any point on an ellipse. \perp s through P to A'P, AP, meet A'A in M and N.

Prove

$$MN = \text{latus rectum}.$$

36. P and Q are any two points on an ellipse. AP and A'Q meet in M, and A'P and AQ meet in N.

Prove

$$MN \perp AA'.$$

138. The eccentric angles of the extremities of two Conjugate diameters differ by a right angle.

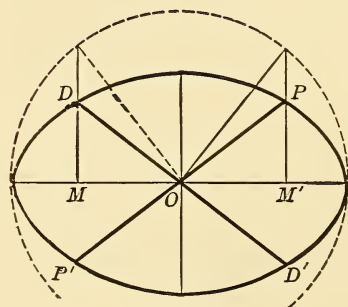

Fig. 119.

Let PP' and DD' be two conjugate diameters. Let the co-ordinates of P be $(a \cos \phi, b \sin \phi)$, and the equations of OP and OD be $y = mx$, and $y = m_1 x$, respectively.

$$\text{Then, } m = \frac{y}{x} = \frac{b \sin \phi}{a \cos \phi},$$

$$\text{and } m_1 = \frac{b \sin \phi_1}{a \cos \phi_1}.$$

$$\therefore mm_1 = -\frac{b^2}{a^2} = \frac{b^2 \sin \phi \sin \phi_1}{a^2 \cos \phi \cos \phi_1},$$

whence

$$\cos \phi \cos \phi_1 + \sin \phi \sin \phi_1 = 0.$$

$$\therefore \phi_1 - \phi = \frac{\pi}{2}.$$

\therefore , etc.

139. $\overline{OP}^2 + \overline{OD}^2$ is constant. — Let the eccentric angle of P be ϕ , then that of D is $\phi + \frac{\pi}{2}$. Then P is the point $[x_1, y_1]$ or, $[a \cos \phi, b \sin \phi]$, and D is $[x_2, y_2]$, or

$$\left[a \cos \left(\phi + \frac{\pi}{2} \right), b \sin \left(\phi + \frac{\pi}{2} \right) \right], \text{ or, } [-a \sin \phi, b \cos \phi].$$

$$\therefore \overline{OP}^2 = x_1^2 + y_1^2 = a^2 \cos^2 \phi + b^2 \sin^2 \phi,$$

and $\overline{OD}^2 = x_2^2 + y_2^2 = a^2 \sin^2 \phi + b^2 \cos^2 \phi.$

$$\therefore \overline{OP}^2 + \overline{OD}^2 = a^2 + b^2. \therefore, \text{ etc.}$$

140. The area of the parallelogram whose sides are tangents at P, P', D, and D', is constant. —

For its area = $4 \square$ whose adjacent sides are OP, OD,
 = $8 \triangle OPD$,
 = $4(x_1y_2 - y_1x_2)$, § 11, cor. 1.
 = $4ab(\cos^2 \phi + \sin^2 \phi)$,
 = $4ab$.
 \therefore , etc.

141. If P is (x_1, y_1) and D is (x_2, y_2) , to find P' and D'. —

The slope of the tangent through P is $-\frac{b^2x_1}{a^2y_1}$.

\therefore the diameter DD' parallel to it, is

$$y = -\frac{b^2x_1}{a^2y_1}x$$

or, $\frac{xx_1}{a^2} + \frac{yy_1}{b^2} = 0.$

Now D is on this diameter and also on the ellipse.

$$\therefore \frac{x_1x_2}{a^2} + \frac{y_1y_2}{b^2} = 0 \dots \dots \dots (1)$$

and $\frac{x_2^2}{a^2} + \frac{y_2^2}{b^2} = 1 \dots \dots \dots (2)$

Solving (1) and (2) for x_2 and y_2 , we get,

$$x_2 = \pm \frac{a}{b} y_1,$$

$$y_2 = \mp \frac{b}{a} x_1.$$

The upper signs give the co-ordinates of D , and the lower signs those of D' in terms of x_1 and y_1 . Similarly the co-ordinates of P' may be found.

NOTE. — Equation (1) expresses the relation that must exist between the co-ordinates of the extremities of every pair of conjugate diameters; *i. e.*, if the ends of a diameter be given, the ends of its conjugate diameter can be found.

EXERCISES.

1. Any tangent to an ellipse meets the tangent at A in K and the minor axis in k . Prove, $kK = kF$.

NOTE. — In the exercises of this chapter, the letters M, N , etc., do not mean the points M, N , etc., in Fig. 114, § 118. The letters A, A', F, F' , however, always stand for the vertices and foci. [O is center.]

2. Points L, L' , are taken on the minor axis so that

$OL = OL' = OF$. Also, p, p' , are the \perp s from L, L' , on any tangent. Prove

$$p^2 + p'^2 = 2a^2.$$

3. \perp s from the foci on a pair of conjugate diameters meet in R . Show that the locus of R is the ellipse

$$b^2 y^2 + a^2 x^2 = a^2 (a^2 - b^2).$$

4. P is the point of contact of a tangent to the ellipse. The locus of the intersection of a \perp from center on the tangent at P , with the ordinate of P , is the ellipse

$$a^2 x^2 + b^2 y^2 = a^4.$$

5. P, D , are the ends of conjugate diameters, and PD makes an $\angle \psi$ with major axis. d is \perp from O on PD .

Prove

$$d^2 = \frac{1}{2} [a^2 \cos^2 \psi + b^2 \sin^2 \psi].$$

6. The line $x \cos a + y \sin a = p$ will be a normal to the ellipse

$$\frac{x^2}{a^2} + \frac{y^2}{b^2} = 1, \text{ if}$$

$$p^2 (a^2 \sin^2 a + b^2 \cos^2 a) = (a^2 - b^2)^2 \sin^2 a \cos^2 a.$$

NOTE. — Compare given line with equation of normal.

7. Prove that if the semi-conjugate diameters OP and OD meet the tangent at A in R and S, then

$$AR \cdot AS = \text{a constant.}$$

8. α, β , are the eccentric angles of the extremities of a chord of a series of parallel chords.

Prove $\alpha + \beta = \text{a constant.}$

9. P, D, are the ends of two conjugate diameters. A parallel to PD meets OP, OD, and the ellipse, in L, M, N, respectively.

Prove $\overline{NL}^2 + \overline{NM}^2 = \overline{PD}^2$.

10. POP', QOQ', are any two diameters, α, β , the eccentric \angle s of P and Q. A \sphericalangle is formed by tangents at P, P', Q, Q'.

Prove $\text{area of } \sphericalangle = \frac{4ab}{\sin(\alpha - \beta)}$.

11. P is any point on an ellipse. FP = λ , and the \perp from F on tangent at P = λ' .

Prove $\frac{b^2}{\lambda'^2} - \frac{2a}{\lambda} + 1 = 0$.

12. The \perp from O on tangent at P = λ , OP = λ' .

Prove $\lambda^2 = \frac{a^2 b^2}{[a^2 + b^2 - \lambda'^2]}$.

13. POP', DOD', are conjugate diameters of the ellipse $\frac{x^2}{a^2} + \frac{y^2}{b^2} = 1$.

L is any point on the circle $x^2 + y^2 = r^2$.

Prove $\overline{LP}^2 + \overline{LP'}^2 + \overline{LD}^2 + \overline{LD'}^2 = 4r^2 + 2(a^2 + b^2)$.

14. MFM' is the latus rectum. Any ordinate PN is prolonged to meet the tangent at M in S.

Prove FP = SN.

15. FG, FG', are \perp s from focus F on a pair of conjugate diameters. Prove the line GG' meets the major axis in a fixed point.

142. Equal conjugate diameters. — If AA' and BB' are the axes of an ellipse, then the diameters parallel to AB and A'B are equal [by symmetry] and they are conjugate. Hence, the equi-conjugate diameters are the diagonals of the rectangle whose sides are tangents to the ellipse at the extremities of the axes.

Their equations are $y = \pm \frac{b}{a} x$.

To find their length, we have

$$\overline{OP}^2 + \overline{OD}^2 = a^2 + b^2; \quad \S 139$$

and if

$$OP = OD = a_1,$$

then

$$2 a_1^2 = a^2 + b^2. \quad \therefore, \text{ etc.}$$

143. Supplemental Chords.—The lines joining any point of an ellipse to the ends of a diameter are called supplemental chords.

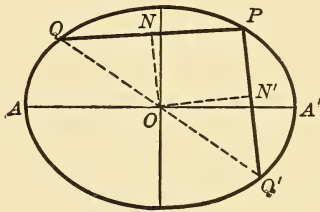

Fig. 120.

Thus, PQ and P'Q' are such chords.

Draw ON \parallel to P'Q' and ON' \parallel to PQ.

Then N and N' are the mid-points of PQ and P'Q'.

\therefore ON will bisect chords parallel to P'Q', and ON' will bisect chords parallel to PQ.

\therefore ON and ON' are conjugate diameters.

This can be easily proved analytically by the student.

To draw a pair of conjugate diameters which shall include a given angle, we proceed thus:

On AA' describe a segment of a circle to contain the given angle, and cutting the ellipse in L and L'. Then the diameters parallel to LA and LA' or L'A and L'A' are evidently those required.

144. Poles and polars.—The chord of contact of any point (x_1, y_1) is

$$\frac{xx_1}{a^2} + \frac{yy_1}{b^2} = 1.$$

The polar of (x_1, y_1) is

$$\frac{xx_1}{a^2} + \frac{yy_1}{b^2} = 1.$$

The polar of the focus $(ae, 0)$ is

$$x = \frac{a}{e},$$

\therefore tangents at the ends of a focal chord meet in the directrix.

NOTE.—The above equations are easily found by proceeding in a manner analogous to that used in the circle and parabola. The theorems and remarks given there hold true here also.

145. Equation of the ellipse referred to a pair of Conjugate Diameters. — The formulæ for transformation are,

$$\begin{aligned} x &= x' \cos \theta + y' \cos \theta', \\ y &= x' \sin \theta + y' \sin \theta', \end{aligned}$$

where θ and θ' are the angles made by the diameters [new axes] with the former x -axis.

Then, substituting and dropping accents, the equation

$$\frac{x^2}{a^2} + \frac{y^2}{b^2} = 1$$

becomes,

$$\begin{aligned} \left[\frac{\cos^2 \theta}{a^2} + \frac{\sin^2 \theta}{b^2} \right] x^2 + 2 \left[\frac{\cos \theta \cos \theta'}{a^2} + \frac{\sin \theta \sin \theta'}{b^2} \right] xy \\ + \left[\frac{\cos^2 \theta'}{a^2} + \frac{\sin^2 \theta'}{b^2} \right] y^2 = 1. \quad \dots \quad (1) \end{aligned}$$

But $\tan \theta \cdot \tan \theta' = \frac{\sin \theta \sin \theta'}{\cos \theta \cos \theta'} = -\frac{b^2}{a^2}$, § 137.

$$\therefore \frac{\sin \theta \sin \theta'}{b^2} + \frac{\cos \theta \cos \theta'}{a^2} = 0.$$

\therefore (1) reduces to,

$$\left[\frac{\cos^2 \theta}{a^2} + \frac{\sin^2 \theta}{b^2} \right] x^2 + \left[\frac{\cos^2 \theta'}{a^2} + \frac{\sin^2 \theta'}{b^2} \right] y^2 = 1. \quad (2)$$

Hence the curve is obliquely symmetrical with respect to its new axes.

If $\pm a_1$ and $\pm b_1$ are its intercepts on the axes, we have

$$\left. \begin{aligned} \frac{1}{a_1^2} &= \text{coefficient of } x^2, \\ \frac{1}{b_1^2} &= \text{coefficient of } y^2, \end{aligned} \right\} \text{ in equation (2).}$$

Hence the equation may be written

$$\frac{x^2}{a_1^2} + \frac{y^2}{b_1^2} = 1 \dots \dots \dots (3)$$

or, when the axes are the equi-conjugate diameters, we have

$$x^2 + y^2 = a_1^2.$$

The equation (3) has the same form as the equation of the ellipse referred to its own axes. Hence, any formulæ derived from the equation

$$\frac{x^2}{a^2} + \frac{y^2}{b^2} = 1,$$

which are independent of the angle between the axes, will also hold true when the ellipse is referred to a pair of conjugate diameters; *e.g.*, the tangent at (x_1, y_1) referred to the conjugate diameters is

$$\frac{xx_1}{a^2} + \frac{yy_1}{b^2} = 1.$$

Likewise for the chord of contact, polar, etc.

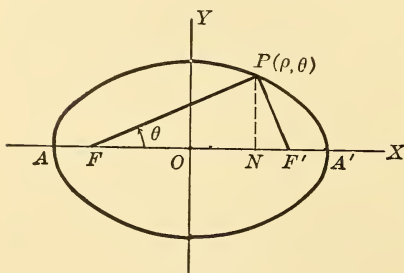

Fig. 121.

146. Polar equation of the ellipse referred to left-hand Focus.

P is any point (ρ, θ) on the ellipse.

$$\begin{aligned} \text{Now } \rho &= a + ex, \\ \text{and } x &= ON = FN - FO \\ &= \rho \cos \theta - ae. \\ \therefore \rho &= a + e\rho \cos \theta - ae^2, \end{aligned}$$

whence

$$\rho = \frac{a(1 - e^2)}{1 - e \cos \theta}.$$

DISCUSSION :

- When $\theta = 0$, $\rho = a + ae = FA'$.
 $\theta = \frac{\pi}{2}$, $\rho = a(1 - e^2) = \text{semi-latus rectum}$.
 $\theta = \pi$, $\rho = a - ae = FA$.
 $\theta = \frac{3}{2}\pi$, $\rho = a(1 - e^2) = \text{semi-latus rectum}$.
 $\theta = 2\pi$, $\rho = a + ae = FA'$.

SUMMARY. — As θ varies from 0 to π , ρ decreases from $a + ae$ to $a - ae$; and as θ varies from π to 2π , ρ increases from $a - ae$ to $a + ae$. Since $e < 1$ and $\cos \theta$ cannot be > 1 , ρ is always positive.

Referred to the right-hand focus, the equation of the ellipse is

$$\rho = \frac{a(1 - e^2)}{1 + e \cos \theta}.$$

The discussion is left to the student.

EXERCISES.

1. A focal chord is \perp to the line joining its pole to the focus.
2. PN is any ordinate of an ellipse, and the \perp from P on its polar meets the major axis in L.

Prove $OL = e^2 \cdot ON$.

3. Show that the pole of the line $x \cos \alpha + y \sin \alpha = p$ is

$$\left[\frac{a^2 \cos \alpha}{p}, \quad \frac{b^2 \sin \alpha}{p} \right].$$

SUGGESTION. — Compare given line with equation of polar.

4. Show that the locus of a point whose polars with regard to the ellipse $\frac{x^2}{a^2} + \frac{y^2}{b^2} = 1$ touch the circle $x^2 + y^2 = r^2$, is the ellipse

$$\frac{x^2}{a^4} + \frac{y^2}{b^4} = \frac{1}{r^2}.$$

5. Tangents to a parabola at P, Q, meet in T. Any other tangent meets TP, TQ, in M, N. Show that the locus of the intersection of PN and QM is an ellipse touching TP and TQ at P and Q, respectively.

6. OP, OD, are conjugate radii of an ellipse, AA', BB', axes. Prove,

(1) $PA \cdot PA' = DB \cdot DB'$.

(2) The bisectors of \angle s $\triangle APA'$, $\triangle BDB'$, are \perp .

7. The product of the three normals that can be drawn from a point (h, k) to ellipse $\frac{x^2}{a^2} + \frac{y^2}{b^2} = 1$ is

$$\frac{2ab(a^2 - e^2h^2)^{\frac{3}{2}}}{a^2 - b^2}.$$

8. Prove that normals to the ellipse from any point on either of the lines $a^2x^2 - b^2y^2 = 0$ meet the curve in points, a pair of whose joins are parallel.*

9. Two supplemental chords of an ellipse, PQ, P'Q, meet the tangents at P' and P in T', T, respectively.

Prove, $PT \cdot P'T'$ is constant.

10. In Fig. 117, § 135, prove FL' and F'L meet on the mid-point of the normal PN.

11. P and D are the extremities of two conjugate diameters. The feet of \perp s from center on the tangents at P and D are M, M', and the \perp s meet the ellipse in N and N'.

Prove, $\frac{1}{OM^2 \cdot ON^2} + \frac{1}{OM'^2 \cdot ON'^2} = \frac{1}{a^4} + \frac{1}{b^4}$.

12. Points L, L', are taken on the normal at P so that PL = PL' = OD.

Prove $OL = a - b$, $OL' = a + b$.

NOTE. — P and D have same meaning as in preceding exercise.

13. Two tangents to the ellipse from T make an $\angle \phi$.

Prove, $\cos \phi = \frac{\overline{FT}^2 + \overline{F'T}^2 - 4a^2}{2\overline{FT} \cdot \overline{F'T}}$ [where F, F', are foci].

EXERCISES ON CHAPTER VIII.

1. Show that the angle between two conjugate diameters is a maximum when they are equal.

2. Find the polar of the focus with reference to each auxiliary circle.

Ans. $ex = a$, $ex = \frac{b^2}{a}$

NOTE. — The minor auxiliary circle is $x^2 + y^2 = b^2$.

* The join of two points is the line between them.

3. Angle between the equi-conjugate diameters of an ellipse is 120° . Show, eccentricity = $\frac{1}{3}\sqrt{6}$.

4. The tangent at end of latus rectum is $y + ex = a$.

5. Length of chord joining ends of two conjugate diameters is $\sqrt{a^2 + b^2 + a^2 e^2 \sin 2\phi}$. Show that its greatest value is $a\sqrt{2}$.

NOTE. — ϕ is eccentric \angle of one end; $\phi + \frac{\pi}{2}$ of other end.

6. Find locus of vertices of \sphericalangle s constructed on the conjugate diameters of an ellipse.

7. Of all \sphericalangle s circumscribed about the same ellipse, those constructed on two conjugate diameters have a minimum area.

8. Of all \sphericalangle s inscribed in same ellipse, those whose diagonals are conjugate diameters have a maximum area.

9. To inscribe the greatest ellipse in a given \sphericalangle .

10. To circumscribe the least ellipse about a given \sphericalangle .

11. From an external point to draw a tangent to an ellipse. Also a normal.

12. Of all pairs of conjugate diameters of an ellipse, the axes of the curve for the least sum, and the equi-conjugate diameters the greatest sum.

13. Any rectangle being circumscribed about an ellipse, show that the \sphericalangle formed by joining the points of contact of the sides has a constant perimeter; also two consecutive sides make equal angles with the tangent.

14. Find the poles of the directrix of the ellipse with regard to the auxiliary circles.

$$\text{Ans. } (ae, o); \left(\frac{e}{a} b^2, o\right).$$

15. In an ellipse, show that the equi-conjugate semi-diameter is to the semi-diagonal on the axes as $1 : \sqrt{2}$.

16. Given an ellipse and $\odot x^2 + y^2 = a^2$, find locus of intersection of normals drawn to the ellipse and circle at corresponding points.

$$\text{Ans. A circle, } x^2 + y^2 = (a + b)^2.$$

17. A \triangle is inscribed in an ellipse, d_1, d_2, d_3 , are semi-diameters parallel to the sides of the \triangle , and R is the radius of its circumscribed circle. Prove,

$$R = \frac{d_1 \cdot d_2 \cdot d_3}{ab}$$

18. Show that the locus of poles of normal chords of an ellipse is

$$x^2 y^2 (a^2 - b^2)^2 = a^6 y^2 + b^6 x^2.$$

19. In the ellipse $\frac{x^2}{a^2} + \frac{y^2}{b^2} = 1$

find the diameters conjugate to

$$\begin{aligned} (1) \quad & ax - by = 0, \\ (2) \quad & bx - ay = 0. \end{aligned}$$

$$\text{Ans. } \begin{cases} a^3 y + b^3 x = 0, \\ ay + bx = 0. \end{cases}$$

20. Show that the line $x \cos \alpha + y \sin \alpha = p$ is a tangent to the ellipse if

$$p = \sqrt{a^2 \cos^2 \alpha + b^2 \sin^2 \alpha}.$$

21. A chord PQ parallel to AB meets OA, OB, in p, q .

Prove,

$$Pp = Qq.$$

Also, if PM, QN, are the ordinates of P and Q, prove,

$$2 AM \cdot AN = \overline{AP}^2.$$

22. Any diameter meets parallels through P, D, to any tangent in p, d [where P, D, are ends of conjugate diameters], and the tangent in T.

Prove,

$$\overline{Op}^2 + \overline{Od}^2 = \overline{OT}^2.$$

23. Any line through vertex A meets the ellipse in M, and minor axis in N. OP is a semi-diameter parallel to AM.

Prove,

$$AM \cdot AN = 2 \overline{OP}^2.$$

24. P and Q are the points of contact of the tangents to an ellipse from T (h, k). Prove,

$$FP \cdot FQ = \frac{\overline{FT}^2}{\left\{ \frac{h^2}{a^2} + \frac{k^2}{b^2} \right\}} \quad [\text{F is the focus}].$$

25. P, Q, R, are any three points on an ellipse. The diameter bisecting QR meets PQ, PR, and the curve in M, N, and L.

Prove,

$$OM \cdot ON = \overline{OL}^2 \quad [\text{O is the center always}].$$

26. Find for the locus in Ex. 18, the result

$$\frac{a^6}{x^2} + \frac{b^6}{y^2} = a^4 e^4,$$

which is the locus of the pole of a normal chord to the ellipse.

27. The center of a circle of constant radius moves on a diameter of the ellipse. Find the locus of the intersection of the common chords of the ellipse and the circle.

28. An ellipse which intersects a fixed straight line revolves about its center. Find the locus of the intersection of the tangents to the ellipse at its points of meeting with the line.

NOTE. — Turning the axes of co-ordinates through a negative angle is the same as turning the ellipse through a positive angle.

29. Show that the polar of a point on a diameter is parallel to the conjugate diameter.

30. The ratio of the subnormals for corresponding points on the ellipse and circle $x^2 + y^2 = a^2$ is $\frac{a^2}{b^2}$.

31. $P_1 P_2$ is any chord of an ellipse \perp to AA' . Find locus of the intersection of $A'P_1$ with AP_2 . *Ans.* An hyperbola, same axes as ellipse.

32. Show that the \perp from center of an ellipse to a line joining the ends of two \perp diameters is constant.

33. A \perp is drawn from focus to a diameter. Find locus of its intersection with the conjugate diameter.

Ans. Straight line \perp major-axis.

34. The semi-major axis of an ellipse is a mean proportional between the intercepts on that axis of the lines which join any point of the curve to the extremities of the minor axis.

35. With the co-ordinates of any point of an ellipse as semi-axes, a concentric ellipse is described, its axes in same direction as those of given ellipse. Prove that the lines joining the extremities of the axes of the first ellipse are tangent to the second.

36. The locus of the mid-point of the chord of contact of two \perp tangents to an ellipse is

$$(a^2 + b^2) (b^2x^2 + a^2y^2)^2 = a^4b^4 (x^2 + y^2).$$

37. The \perp from center of ellipse on tangent at $P = \frac{ab}{b'}$ where b' is the semi-diameter, conjugate to the diameter through P .

38. Two conjugate diameters of an ellipse are prolonged to cut the tangent at the vertex. Prove that the semi-minor axis is a mean proportional between the parts of tangent cut off.

39. The product of the distances of the center of the director circle and of any point on it from the polar of the point [with respect to the ellipse] is constant.

40. The ordinate of any point on an ellipse is produced to meet the tangent at the end of latus rectum. Show that the length of the extended ordinate equals the length of the corresponding focal radius of the point.

41. Tangents from P to an ellipse make angles θ and θ' with major axis. Find locus of P if

(1) $\tan \theta \tan \theta' = k$, a constant.

Ans. $y^2 - b^2 = k(x^2 - a^2)$, an ellipse or hyperbola according as k is negative or positive.

(2) $\theta + \theta' = 2\phi$, a constant.

Ans. $(y^2 - x^2 + a^2 - b^2) \tan 2\phi + 2xy = 0$.

(3) $\tan \theta + \tan \theta' = k$, a constant. *Ans.* $kx^2 - 2xy = ka^2$.

42. P is any point on auxiliary circle $x^2 + y^2 = a^2$. The tangent at P meets AA' in T. If PA, PA', meet the ellipse in M, N, prove that chord MN passes through T.

43. Also, \perp s from foci of ellipse on the tangent at P [Ex. 42] meet the ellipse in Q, Q'.

Prove PQ, PQ', are tangents to the ellipse.

44. P, Q, are the points of contact of tangents from T (h, k). Prove, area of $\triangle OPQ$ [O is center of ellipse].

$$= \frac{a^2 b^2 \sqrt{b^2 h^2 + a^2 k^2 - a^2 b^2}}{b^2 h^2 + a^2 k^2},$$

and area of quadrilateral TPOQ

$$= \sqrt{b^2 h^2 + a^2 k^2 - a^2 b^2}.$$

45. TP, TQ, are tangents from T so that PQ subtends a right angle at the center of ellipse. Show that the locus of T is the ellipse

$$\frac{x^2}{a^4} + \frac{y^2}{b^4} = \frac{1}{a^2} + \frac{1}{b^2}.$$

46. The locus of the centers of equilateral \triangle s whose sides touch the ellipse $\frac{x^2}{a^2} + \frac{y^2}{b^2} = 1$ is the curve

$$9(x^2 + y^2)^2 - 2(5a^2 + 3b^2)x^2 - 2(3a^2 + 5b^2)y^2 + (a^2 - b^2)^2 = 0.$$

47. Tangents are drawn to the ellipse at two points whose eccentric angles differ by $\frac{2}{3}\pi$ or 120° . Show that the locus of their intersection is the ellipse

$$\frac{x^2}{a^2} + \frac{y^2}{b^2} = 4.$$

48. A parallelogram is circumscribed about the ellipse $\frac{x^2}{a^2} + \frac{y^2}{b^2} = 1$.

If two opposite vertices trace out the curve

$$f(x, y) = 0,$$

find the curve traced by the other two.

$$\text{Ans. } f\left[-\frac{ay}{b\lambda}, \frac{bx}{a\lambda}\right] = 0,$$

$$\text{where } \lambda^2 = \frac{x^2}{a^2} + \frac{y^2}{b^2} - 1.$$

CHAPTER IX

THE HYPERBOLA

147. **Definition.** — If P is a point on the curve, then

$$F'P = e \cdot PM',$$

where F' is the focus, PM' the \perp from focus to directrix DD' , and $e > 1$.

148. To find the equation of the hyperbola.

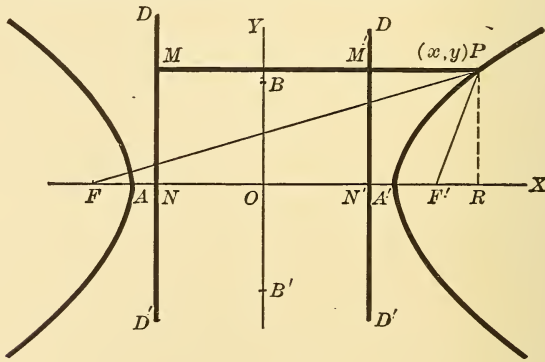

Fig. 122.

Draw $FN \perp$ to directrix. Take points A and A' on FN such that

$$FA = e \cdot AN \quad \dots \dots \dots (1)$$

$$FA' = e \cdot A'N \quad \dots \dots \dots (2)$$

Then A and A' are points on the curve [the vertices].

Bisect AA' in O , and let $AA' = 2a$.

Add (1) and (2), we obtain

$$2 OF = e \cdot 2 OA,$$

$$\therefore OF = ae.$$

Subtract (1) from (2),

$$2 OA = e \cdot 2 ON,$$

$$\therefore ON = \frac{a}{e}.$$

Now, through O draw $BOB' \perp$ to OA. Take OA and OB as axes.

F is the point $(-ae, O)$, F' is (ae, O) .

$$\overline{F'P}^2 = e^2 \cdot \overline{PM}^2 \text{ [by definition],}$$

but $\overline{F'P}^2 = (x - ae)^2 + y^2,$

also, $PM' = OR - ON' = x - \frac{a}{e}.$

$$\therefore (x - ae)^2 + y^2 = (ex - a)^2.$$

$$\therefore x^2(e^2 - 1) - y^2 = a^2(e^2 - 1) \dots (1)$$

The intercepts of this on the y -axis are imaginary and equal to $\pm a \sqrt{-(e^2 - 1)}$.

Put $a^2(e^2 - 1) = b^2,$

and divide (1) by its dexter,

$$\therefore \frac{x^2}{a^2} - \frac{y^2}{b^2} = 1 \dots (2)$$

is the equation of the hyperbola.

Its intercepts [imaginary] on the y -axis may also be written,

$$y = \pm b \sqrt{-1}.$$

\therefore hyperbola does not meet y -axis in real points.

It is, however, convenient to measure $OB = OB' = b.$

If in (1) we put $x = ae$ (OF), we get

$$y^2 = b^2(e^2 - 1) = \frac{b^4}{a^2}.$$

$$\therefore 2y = \frac{2b^2}{a} = \text{latus rectum}$$

[double ordinate through the focus].

DISCUSSION OF (2):

- (1) Symmetrical to x -axis [called \therefore transverse axis].
- (2) Symmetrical to y -axis [called \therefore conjugate axis].
- (3) Symmetrical to origin [called \therefore the center].
- (4) No part of the curve lies between the lines $x = \pm a$, since for values of x between $+a$ and $-a$, y is imaginary. Also, while x increases from a to ∞ , y increases from 0 to ∞ . Hence the curve has two infinite branches lying outside of the lines $x = \pm a$.
- (5) The curve has two foci and two directrices.

149. The difference between the focal distances of any point on the curve is constant and equal to $2a$. —

$$F'P = e \cdot PM' = e \cdot (OR - ON') = ex - a.$$

$$FP = e \cdot PM = e \cdot (OR + ON) = ex + a.$$

$$\therefore FP - F'P = 2a.$$

\therefore , etc.

NOTE. — The polar equation of the hyperbola with center as pole is obtained by putting $x = \rho \cos \theta$, $y = \rho \sin \theta$.

$$\therefore \frac{\rho^2 \cos^2 \theta}{a^2} - \frac{\rho^2 \sin^2 \theta}{b^2} = 1.$$

$$\therefore \rho^2 = \frac{a^2 b^2}{b^2 \cos^2 \theta - a^2 \sin^2 \theta} = \frac{a^2 b^2}{b^2 - (a^2 + b^2) \sin^2 \theta}$$

[The discussion of this equation is left for the student.]

150. Construction of the curve. — This is based on the principle of § 149. The foci and $2a$ are given.

(1) *Mechanical*:

Pivot one end of a ruler about the focus F , and to the other end join a string whose length is less than that of the ruler by $2a$. Press the string against the ruler by a pencil-

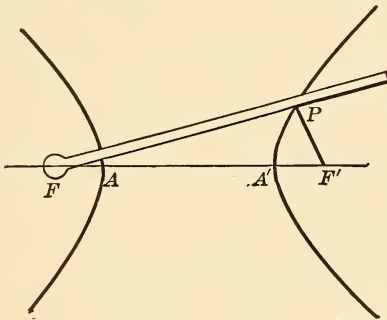

Fig. 123.

point P , while turning the ruler about F . The point P will describe one branch of the curve, for in every position we have $PF - PF' = 2a$. For the other branch, interchange the fixed end of the ruler and the end of the string.

(2) *By points :*

Bisect $F'F$ in O . In $F'F$ produced take any point D . Also lay off $OA = OA' = a$. Now, with F' as center and $A'D$ as

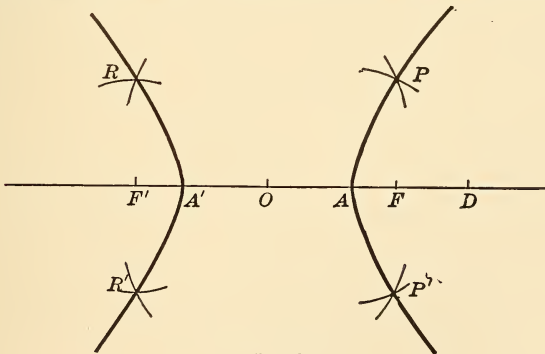

Fig. 124.

radius, describe two arcs. Then with F as center, AD as radius, describe two arcs cutting the former in P and P'. These are evidently points on the curve. By interchanging radii, R and R' are found. After a sufficient number of points have thus been found, they are joined by a smooth curve.

NOTE. — Since the equations of the ellipse and hyperbola differ only in the sign of b^2 , any formula deduced for the ellipse may be changed to the corresponding formula for the hyperbola by changing b^2 to $-b^2$ or b to $b\sqrt{-1}$.

151. The equilateral hyperbola. — This is an hyperbola whose transverse and conjugate axes are equal.

Its equation is, $\therefore x^2 - y^2 = a^2$.

Also, since $b^2 = a^2 (e^2 - 1)$

[put a for b], $\therefore e = \sqrt{2}$.

Its relation to the general hyperbola is analogous to the relation of the auxiliary circle to the ellipse.

152. The conjugate hyperbola. — This is the hyperbola which has BB' for its transverse axis and AA' for its conjugate axis. To get its equation, put x for y , and a for b , in the equation

$$\frac{x^2}{a^2} - \frac{y^2}{b^2} = 1.$$

We obtain $\frac{x^2}{a^2} - \frac{y^2}{b^2} = -1$.

It may also be obtained by turning the axes through an angle of 90° , and then putting a for b , and b for a .

153. The idea of asymptotes. — Let parallels to the axes through A, B, B', etc., meet in K and K'.

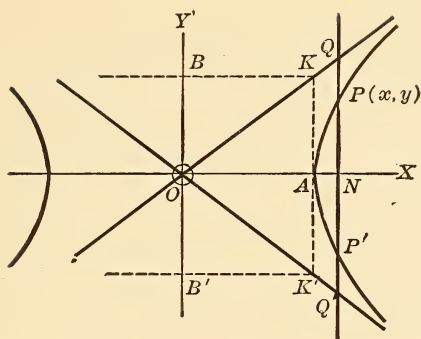

Fig. 125.

P is any point on the curve whose ordinate meets OK in Q. Then from the equation of the hyperbola we get,

$$y [PN] = \frac{b}{a} \sqrt{x^2 - a^2} \quad \dots \dots \dots (1)$$

The equation of OK is $y = \frac{b}{a} x$.

$$\therefore QN = \frac{b}{a} x \quad \dots \dots \dots (2)$$

\therefore PN being always less than QN, we have

$$\begin{aligned} PQ &= \frac{b}{a} [x - \sqrt{x^2 - a^2}] \\ &= \frac{ab}{x + \sqrt{x^2 - a^2}} \end{aligned}$$

From this it is evident that by taking x large enough, PQ may be made less than any assignable quantity. Hence the curve continually approaches the lines OK and OK' [whose equations are $y = \pm \frac{b}{a} x$] but never meets them. These lines are called the asymptotes of the hyperbola.

NOTE. — $\overline{QN}^2 - \overline{PN}^2 = b^2$ [a constant].

154. Another view of asymptotes. — The line $y = mx$, passing through the center of the hyperbola, meets it in two points whose abscissas are,

$$\left. \begin{aligned} x_1 &= \frac{ab}{\sqrt{b^2 - a^2m^2}} \\ x_2 &= \frac{-ab}{\sqrt{b^2 - a^2m^2}} \end{aligned} \right\} \dots \dots \dots (1)$$

It also meets the conjugate hyperbola in two points whose abscissas are,

$$\left. \begin{aligned} x_1 &= \frac{ab}{\sqrt{a^2m^2 - b^2}} \\ x_2 &= \frac{-ab}{\sqrt{a^2m^2 - b^2}} \end{aligned} \right\} \dots \dots \dots (2)$$

Hence the points (1) will be imaginary, situated at infinity, or real, according as $m^2 >, =$, or $< \frac{b^2}{a^2}$.

And the points (2) will be imaginary, situated at infinity, or real, according as $m^2 <, =$, or $> \frac{b^2}{a^2}$.

∴ if a line through the center meet an hyperbola in real points, it meets its conjugate in imaginary points and *vice versa*.

We shall now give a definition of an asymptote; viz., a straight line which passes through finite points and meets a curve in two points at infinity.

∴ if the line meets the hyperbola at infinity, we have $m^2 = \frac{b^2}{a^2}$, and the equation of the line becomes $y = \frac{b}{a}x$.

∴ the hyperbola has two asymptotes [one for each branch], whose equations are

$$y = \frac{b}{a}x, \text{ and } y = -\frac{b}{a}x \text{ or } \frac{x^2}{a^2} - \frac{y^2}{b^2} = 0$$

NOTE 1. — If a line through the center O meets the conjugate hyperbolas in M and N, it can be shown that $\overline{OM}^2 = -\overline{ON}^2$ or $OM = ON \sqrt{-1}$. Or, if M is (h, k) , N is $(h \sqrt{-1}, k \sqrt{-1})$.

∴ if M is a real point, N is imaginary, and *vice versa*.

NOTE 2. — Equations of the hyperbola, conjugate hyperbola, and asymptotes have identical sinisters; viz.,

$$\left. \begin{aligned} \frac{x^2}{a^2} - \frac{y^2}{b^2} &= +1 && \dots \dots \dots (1) \\ \frac{x^2}{a^2} - \frac{y^2}{b^2} &= -1 && \dots \dots \dots (2) \\ \frac{x^2}{a^2} - \frac{y^2}{b^2} &= 0 && \dots \dots \dots (3) \end{aligned} \right\}$$

EXERCISES.

1. AOB and COD are two straight lines which bisect each other at right angles in O. Find the locus of P which moves so that,

$$PA \cdot PB = PC \cdot PD.$$

Ans. Rectangular hyperbola, $x^2 - y^2 = \frac{1}{2}(a^2 - b^2)$, where $AB=2a$, $CD=2b$. Take AB, CD, as axes.

2. The ordinate of a point on a hyperbola is produced until its length equals a focal radius of the point. Find the locus of its extremity.

3. Show that the distances of either focus of an hyperbola from the asymptotes equal half the minor axis.

4. If, from any point of a hyperbola, a line is drawn parallel to either axis, the product of the parts cut off between the point and the asymptotes equals the square of half that axis.

5. P is any point on a rectangular hyperbola.

Prove, $FP \cdot F'P = \overline{OP}^2$. [F, F', are the foci, O the center.]

6. Two straight lines of lengths a and b slide along two rectangular axes in such a manner that their extremities are always concyclic. Find the locus of the center of the circle.

Ans. Hyperbola, $x^2 - y^2 = \frac{1}{4}(a^2 - b^2)$.

7. Prove that the foot of a \perp from a focus to an asymptote is at distances a and b from the center and focus, respectively.

8. P and Q are any two points on a hyperbola. Parallels through P and Q to the asymptotes meet in L and M. Prove that LM passes through the center of the hyperbola.

9. PP' is a chord of the ellipse $\frac{x^2}{a^2} + \frac{y^2}{b^2} = 1$ parallel to its minor axis. Find locus of intersection of AP and A'P'. A and A' are vertices.

Ans. The hyperbola, $\frac{x^2}{a^2} - \frac{y^2}{b^2} = 1$.

10. The eccentricities of two conjugate hyperbolas are e_1 and e_2 . Prove,

$$(1) \frac{1}{e_1^2} + \frac{1}{e_2^2} = 1.$$

$$(2) ae_1 = be_2.$$

11. Prove that the circles described on parallel chords of a rectangular hyperbola as diameters are coaxial.

12. A line through the center O of an hyperbola meets the curve in P, and the lines drawn through the vertex A parallel to the asymptotes, in T, T'. Prove,

$$\overline{OP}^2 = OT \cdot OT'.$$

13. The asymptotes meet the directrices of an hyperbola on the auxiliary circle $x^2 + y^2 = a^2$, and those of its conjugate hyperbola on the circle $x^2 + y^2 = b^2$.

14. The equi-conjugate diameters of the ellipse $\frac{x^2}{a^2} + \frac{y^2}{b^2} = 1$ coincide with the asymptotes of the hyperbola $\frac{x^2}{a^2} - \frac{y^2}{b^2} = 1$.

15. A circle with center at a focus and radius = b , passes through the intersections of the asymptotes and the corresponding directrix.

155. Miscellaneous facts. — Most of the work of the preceding chapter is applicable to the hyperbola if b is changed to $b\sqrt{-1}$, thus:

(1) The tangent at (x_1, y_1) is

$$\frac{xx_1}{a^2} - \frac{yy_1}{b^2} = 1.$$

(2) The normal is

$$y - y_1 = -\frac{a^2 y_1}{b^2 x_1} (x - x_1).$$

(3) The subtangent is $= \frac{x_1^2 - a^2}{x_1}$.

(4) The subnormal $= \frac{b^2 x_1}{a^2}$.

(5) The tangent and normal at any point bisect the angles between its focal radii.

(6) The line $y = mx \pm \sqrt{m^2 a^2 - b^2}$ is a tangent to the hyperbola for all values of m .

(7) The director circle is $x^2 + y^2 = a^2 - b^2$.

(8) The chord of contact of (x_1, y_1) is

$$\frac{xx_1}{a^2} - \frac{yy_1}{b^2} = 1.$$

(9) The polar of (x_1, y_1) is

$$\frac{xx_1}{a^2} - \frac{yy_1}{b^2} = 1.$$

(10) Two distinct, coincident or no tangents to an hyperbola can be drawn from a given point according as it is without, on, or within the curve.

NOTE 1. — The geometrical properties of the ellipse can be proved for the hyperbola in an analogous way.

NOTE 2. — The director circle of the hyperbola is a point circle if $a = b$, and is imaginary if $b > a$.

156. Equation of diameter. Conjugate diameters. — The equation of the diameter is found in the same way as in the ellipse, and is written $y = \frac{b^2}{a^2 m} x$, where m is the slope of the chords.

If $y = m_1 x$ is another diameter which bisects all chords parallel to the first, we have $m_1 = \frac{b^2}{a^2 m}$ or $mm_1 = \frac{b^2}{a^2}$; and if

the first bisects all chords parallel to the second, we get the same relation.

∴ If one diameter bisects all chords parallel to another, the second bisects the chords parallel to the first. Two such diameters are called conjugate diameters; *i.e.*, they go in pairs.

DISCUSSION. — (1) The relation $mm_1 = \frac{b^2}{a^2}$ shows that the slopes of two conjugate diameters are like in sign, hence two such diameters lie on the same side of the conjugate axis of the hyperbola, and their included angle is ∴ acute.

(2) If $m < \frac{b}{a}$, $m_1 > \frac{b}{a}$; but the semi-angle between the asymptotes = $\tan^{-1} \frac{b}{a}$. ∴ of two conjugate diameters, only one meets the curve in real points.

(3) The relation may also be written $\left(\frac{1}{m}\right)\left(\frac{1}{m_1}\right) = \frac{a^2}{b^2}$.

But this is the condition that the lines $y = mx$ and $y = m_1x$, may be conjugate with respect to $\frac{x^2}{a^2} - \frac{y^2}{b^2} = -1$.

Hence, two lines which are conjugate diameters of an hyperbola are also conjugate diameters of its conjugate hyperbola.

157. Eccentric angle. Other properties of the hyperbola.
— Tangents to two conjugate hyperbolas at the extremities of

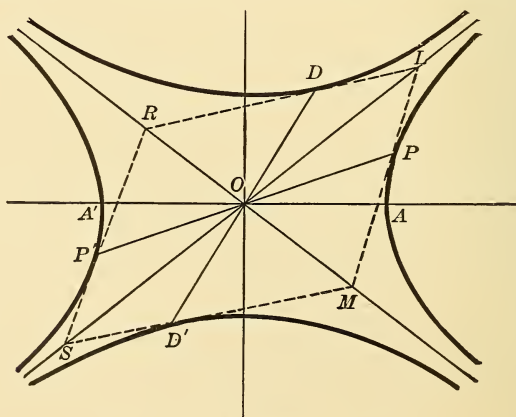

Fig. 126.

two conjugate diameters form a parallelogram whose diagonals coincide with the asymptotes.

Let PP' and DD' be conjugate diameters. Then it is sufficient to show that the tangents at P and D form with OP and OD a parallelogram whose diagonal OL is on one asymptote.

Let the co-ordinates of P be

$$\left. \begin{aligned} x &= a \sec \phi \\ y &= b \tan \phi \end{aligned} \right\} \dots \dots \dots (1)$$

where ϕ is the eccentric angle. These values evidently satisfy the equation of the hyperbola. Then the co-ordinates of D are

$$\left. \begin{aligned} x &= a \tan \phi \\ y &= b \sec \phi \end{aligned} \right\} \dots \dots \dots (2)$$

For, (α) these values satisfy the equation of the conjugate hyperbola,
and (β) the lines OP and OD , whose equations are

$$y = \frac{b \tan \phi}{a \sec \phi} x \dots \dots \dots (3)$$

and

$$y = \frac{b \sec \phi}{a \tan \phi} x \dots \dots \dots (4)$$

satisfy the condition for conjugate diameters, viz.,

$$mm_1 = \frac{b^2}{a^2}.$$

Now, the equation of the tangent at P is

$$\frac{x}{a} \sec \phi - \frac{y}{b} \tan \phi = 1 \dots \dots \dots (5)$$

NOTE. — This is easily found by substituting the co-ordinates of P in $\frac{xx_1}{a^2} - \frac{yy_1}{b^2} = 1$.

[This line is parallel to (4).]

Also, the tangent at D is

$$\frac{x}{a} \tan \phi - \frac{y}{b} \sec \phi = -1 \dots \dots \dots (6)$$

[This line is parallel to (3).]

Adding (5) and (6) we get,

$$\left(\frac{x}{a} - \frac{y}{b}\right)(\sec \phi + \tan \phi) = 0,$$

or,

$$\frac{x}{a} = \frac{y}{b} \cdot$$

$$\therefore y = \frac{b}{a}x.$$

\therefore The lines (5) and (6) meet on the asymptotes. \therefore , etc.

158. The difference between the squares of two conjugate semi-diameters is constant.

From equations (1) and (2), we have,

$$\overline{OP}^2 = a^2 \sec^2 \phi + b^2 \tan^2 \phi,$$

$$\overline{OD}^2 = a^2 \tan^2 \phi + b^2 \sec^2 \phi.$$

$$\therefore \overline{OP}^2 - \overline{OD}^2 = (a^2 - b^2)(\sec^2 \phi - \tan^2 \phi)$$

$$= a^2 - b^2. \quad \therefore, \text{ etc.}$$

159. The area of the parallelogram MLRS is constant.

$$\square \text{ MLRS} = 8 \triangle \text{ POD}$$

$$= 4 (a \sec \phi \cdot b \sec \phi - a \tan \phi \cdot b \tan \phi)$$

$$= 4 ab. \quad \therefore, \text{ etc.}$$

NOTE. — It can be easily shown, both geometrically and analytically, that PD is bisected by one asymptote and is parallel to the other.

160. The portion of a tangent intercepted by the asymptotes is bisected at the point of contact.

$$\text{For} \quad \text{PL} = \text{OD} = \text{OD}' = \text{PM}.$$

\therefore LM is bisected at P.

NOTE 1. — If θ is the angle between OP and OD, and $OP = a_1$, $OD = b_1$, then $\sin \theta = \frac{ab}{a_1 b_1}$.

NOTE 2. — Tangents at the extremities of any chord meet on the diameter of that chord.

NOTE 3. — The polar of a focus is the corresponding directrix.

EXERCISES.

1. A chord of a rectangular hyperbola subtends angles at the extremities of any diameter which are either equal or supplementary.

2. TP and TQ are tangents from T. A parallel to an asymptote drawn through T meets PQ in R. Show that TR is bisected by the [hyperbola] curve.

3. P is any point on a rectangular hyperbola. OL is \perp to the tangent at P. Prove,

$$OP \cdot OL = a^2.$$

4. A \perp from center on any tangent to the hyperbola $x^2 - y^2 = a^2$ meets the curve in L and the curve in L'.

Prove, $OL \cdot OL' = a^2$.

5. An ellipse and an hyperbola have the same axes. Show that the polar of any point on either curve is a tangent to the other.

6. In two conjugate hyperbolas, show that the polar of the vertex of one hyperbola with respect to its conjugate, is the tangent at the other vertex.

7. Conjugate diameters of an equilateral hyperbola are equal.

8. The parts of a normal to an hyperbola cut off by the transverse and conjugate axes, respectively, are in the ratio of $b^2 : a^2$.

9. Every point [except the center of a conic] has a definite polar with respect to the conic, and conversely, every line [excepting one through the center] has a definite pole.

10. The polars of a point with regard to two conjugate hyperbolas are parallel.

11. In an equilateral hyperbola, the length of a normal at any point equals the distance of that point from the center.

12. The line $x \cos \alpha + y \sin \alpha = p$, is normal to the hyperbola

$$\frac{x^2}{a^2} - \frac{y^2}{b^2} = 1,$$

if $p^2 (a^2 \sin^2 \alpha - b^2 \cos^2 \alpha) = (a^2 + b^2)^2 \cdot \sin^2 \alpha \cos^2 \alpha$.

13. The tangents to an equilateral hyperbola at the positive ends of the latus rectum are

$$y = \pm x \sqrt{2} - a.$$

14. Show that the segments of any line which are intercepted between an hyperbola and its asymptotes are equal.

15. Show that tangents from the foot of the directrix to an hyperbola meet the curve at the extremities of the latus rectum. And, if ϕ is the angle between them,

Prove, $\tan \phi = \pm e.$

16. Tangents to an hyperbola are drawn from any point on the conjugate curve. Show that their chord of contact will touch the opposite branch of the conjugate curve.

17. ϕ is the angle between the asymptotes of an hyperbola, e the eccentricity of the curve.

Prove, $\tan \phi = 2 \frac{\sqrt{e^2 - 1}}{2 - e^2}.$

18. P is any point on a rectangular hyperbola. Prove, angles PAA' and PA'A differ by $\frac{\pi}{2}$; and the bisectors of $\angle \text{APA}'$ are parallel to the asymptotes.

19. PQ is a chord of a rectangular hyperbola normal at P. Show that PQ varies as \overline{OP}^3 . [$\text{PQ} \propto \overline{OP}^3$.]

20. From points on the circle $x^2 + y^2 = a^2$ tangents are drawn to the hyperbola $x^2 - y^2 = a^2$. Prove that the locus of the mid-point of the chord of contact is the curve

$$(x^2 - y^2)^2 = a^2 (x^2 + y^2).$$

21. In an equilateral hyperbola show that focal chords parallel to conjugate diameters are equal.

22. Show that the angles between any pair of conjugate diameters of an equilateral hyperbola are bisected by the asymptotes.

23. P, Q, R, are any three points on an equilateral hyperbola. If $\angle \text{PQR} = 90^\circ$, prove that the normal at Q is parallel to PR.

24. A circle, with a focus [of any hyperbola] as a center and radius = b , will touch the asymptotes at the points where they meet the corresponding directrix.

25. Any tangent to an hyperbola meets the asymptotes in C, C'. Prove, C, C', F, F' [foci], are concyclic.

26. The segment of a tangent to an hyperbola intercepted by the conjugate hyperbola, is bisected at the point of contact.

161. The asymptote is a tangent from the center. — If the tangent $y = mx \pm \sqrt{m^2a^2 - b^2}$ pass through the center, its intercept is zero.

$$\therefore \sqrt{m^2a^2 - b^2} = 0.$$

whence
$$m = \pm \frac{b}{a}.$$

Hence the equation of the tangent becomes

$$y = \pm \frac{b}{a}x; \text{ i.e., an asymptote. } \therefore, \text{ etc.}$$

162. Equation of the hyperbola referred to its asymptotes.

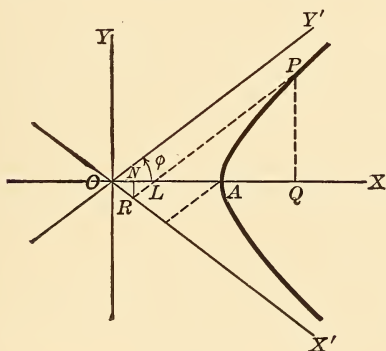

Fig. 127.

OX' and OY' are the asymptotes, ϕ is the semi-angle between them. P is (x, y) to the former axes, (x', y') to the new axes.

$$\begin{aligned} x &= ON + NL + LQ = OR \cos \phi + RL \cos \phi + LP \cos \phi \\ &= (OR + PR) \cos \phi, \end{aligned}$$

$$\therefore x = (x' + y') \cos \phi.$$

$$y = PQ = PL \sin \phi = (PR - LR) \sin \phi = (PR - OR) \sin \phi.$$

$$\therefore y = (y' - x') \sin \phi.$$

∴ Substituting these values in the equation

$$\frac{x^2}{a^2} - \frac{y^2}{b^2} = 1,$$

we obtain

$$\frac{(x' + y')^2 \cos^2 \phi}{a^2} - \frac{(y' - x')^2 \sin^2 \phi}{b^2} = 1.$$

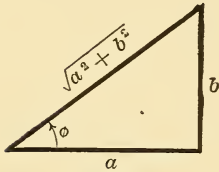

Fig. 128.

Also, since $\tan \phi = \frac{b}{a}$,

$$\sin \phi = \frac{b}{\sqrt{a^2 + b^2}},$$

$$\cos \phi = \frac{a}{\sqrt{a^2 + b^2}}.$$

Substituting also these values above, we finally obtain, after dropping accents,

$$4xy = a^2 + b^2$$

as the required equation.

The conjugate hyperbola is

$$4xy = -(a^2 + b^2).$$

NOTE. — In the figure of § 159, if the co-ordinates of P, referred to the asymptotes, are (x, y) , those of D are $(-x, y)$.

163. The product of the \perp s from any point of an hyperbola on the asymptotes is constant. — Let P [Fig. 127, § 162] be the given point, d_1 its \perp distance from OX' , d_2 the \perp on OY' .

$$\text{Then,} \quad d_1 = PR \sin 2\phi = y' \sin 2\phi.$$

$$d_2 = x' \sin 2\phi,$$

$$\text{or,} \quad d_1 \cdot d_2 = xy \cdot \sin 2\phi \text{ [after dropping accents]} \\ = \text{a constant}$$

[since $xy = \text{a constant}$]. ∴, etc.

164. Equation of a hyperbola with given asymptotes

$$A_1x + B_1y + C_1 = 0, \quad A_2x + B_2y + C_2 = 0.$$

By the preceding §, if (x, y) is any point on the required hyperbola, we have

$$\frac{A_1x + B_1y + C_1}{\sqrt{A_1^2 + B_1^2}} \cdot \frac{A_2x + B_2y + C_2}{\sqrt{A_2^2 + B_2^2}} = \text{some constant,}$$

or, $(A_1x + B_1y + C_1)(A_2x + B_2y + C_2) = \text{a constant } k$

is the equation of the hyperbola.

NOTE. — It differs from the equation of the asymptotes which is, $(A_1x + B_1y + C_1)(A_2x + B_2y + C_2) = 0$, by some constant.

And the equation of the conjugate hyperbola is $(A_1x + B_1y + C_1)(A_2x + B_2y + C_2) = -k$.

Hence, whatever the axes of co-ordinates may be, the two conjugate hyperbolas differ only in their constant [numerical] terms, whose values are equal and opposite in sign.

165. The equation of the tangent at (x_1, y_1) to the hyperbola $xy = k^2$. — Let (x_2, y_2) be an adjacent point of the curve. Then the chord is

$$\frac{y - y_1}{x - x_1} = \frac{y_1 - y_2}{x_1 - x_2} \dots \dots \dots (1)$$

but $x_1y_1 = k^2 \dots \dots \dots (2)$

$$x_2y_2 = k^2 \dots \dots \dots (3)$$

$$\therefore \frac{y_1 - y_2}{x_1 - x_2} = [m] = \frac{\frac{k^2}{x_1} - \frac{k^2}{x_2}}{\frac{x_1}{x_1} - \frac{x_2}{x_2}} = \frac{-k^2}{x_1x_2}.$$

\therefore (1) becomes $\frac{y - y_1}{x - x_1} = -\frac{k^2}{x_1x_2}$ [equation of secant].

Putting $x_2 = x_1$,

we obtain, $\frac{y - y_1}{x - x_1} = -\frac{k^2}{x_1^2}$ [equation of tangent],

which may be written in either of the two forms,

$$\frac{x}{x_1} + \frac{y}{y_1} = 2,$$

OR

$$xy_1 + x_1y = 2k^2.$$

NOTE. — The equation of the hyperbola whose asymptotes are

$$\left. \begin{aligned} x - 2y + 1 &= 0, \\ x + 3y + 2 &= 0, \end{aligned} \right\}$$

is $(x - 2y + 1)(x + 3y + 2) + k = 0,$
and conjugate hyperbola is $(\dots)(\dots) - k = 0.$ Hence another condition is required to determine $k.$

Also, the asymptotes of the hyperbola

$$x^2 + 2xy - y^2 + 8x + 4y - 8 = 0$$

are

$$x^2 + 2xy - y^2 + 8x + 4y + k = 0 \quad \dots \dots (1)$$

where k is determined by the condition that (1) may represent two straight lines [see § 48].**EXERCISES.**1. A circle meets the hyperbola $xy = k^2$ in four points, $(x_1, y_1), (x_2, y_2), (x_3, y_3), (x_4, y_4).$

Prove,

$$x_1x_2x_3x_4 = k^4 = y_1y_2y_3y_4.$$

SUGGESTION. — Express that points are concyclic. Also each lies on hyperbola, etc.

2. Show that any tangent to the hyperbola $x^2 - y^2 = 2a^2$ is cut harmonically by the hyperbolas

$$\left. \begin{aligned} x^2 + xy &= a^2, \\ y^2 + xy &= -a^2. \end{aligned} \right\}$$

SUGGESTION. — Find equation of tangent to given hyperbola in terms of slope.

NOTE. — On harmonic division of a straight line. The line AC is said to be divided harmonically in B, D, if it is divided internally at B and externally at D in the same ratio. Thus,

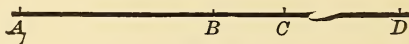

Fig. 129.

$$\frac{AB}{BC} = \frac{AD}{DC} = \frac{m}{n}, \text{ say.}$$

The name harmonic comes from the fact that AB, AC, AD, are in harmonic progression. Thus,

put $AB = a, AC = b, AD = c,$
 then $\frac{AB}{BC} = \frac{AD}{CD}, \therefore \frac{a}{b-a} = \frac{c}{c-b},$
 $\therefore a(c-b) = c(b-a).$

Divide by $abc, \therefore \frac{1}{b} - \frac{1}{c} = \frac{1}{a} - \frac{1}{b} \therefore \frac{1}{a}, \frac{1}{b}, \frac{1}{c},$ are in A.P. $\therefore,$ etc.

It may also be shown that DC, DB, DA, are in H. P. Again, if M is the mid-point of AC, then we may readily show that

$$MB \cdot MD = \overline{MC}^2.$$

3. A series of chords of the hyperbola $\frac{x^2}{a^2} - \frac{y^2}{b^2} = 1$ are tangents to the circle described on the distance between the foci as diameter. Show that the locus of their poles with respect to the hyperbola is the ellipse

$$\frac{x^2}{a^4} + \frac{y^2}{b^4} = \frac{1}{a^2 + b^2}.$$

4. The pole of any tangent to the rectangular hyperbola $xy = k^2$ with respect to the circle $x^2 + y^2 = a^2,$ lies on a concentric rectangular hyperbola with axes coincident with those of former.

5. The polar of any point T is parallel to the lines joining the points of intersection of the tangents from T with the asymptotes.

6. Show that the tangents to the hyperbola $xy = k^2$ at the points (x_1, y_1) and (x_2, y_2) meet at the point,

$$\left[\frac{2x_1x_2}{x_1+x_2}, \frac{2y_1y_2}{y_1+y_2} \right].$$

7. Show that the asymptotes of the hyperbola

$$xy = hx + ky \text{ are } x - k = 0, y - h = 0,$$

and its conjugate hyperbola is

$$xy = hx + ky - 2hk.$$

8. The asymptotes of the hyperbola $2xy = hy + kx$ are

$$\left. \begin{aligned} 2x &= h, \\ 2y &= k. \end{aligned} \right\}$$

9. PM, PN, are \perp s from P on two fixed lines meeting at O, and area of quadrilateral OMPN = k^2 [a constant]. If the angle between the lines is $\phi,$ show that the locus of P, the given lines as axes, is the hyperbola

$$x^2 + 2xy \sec \phi + y^2 = \frac{4k^2}{\sin 2\phi}.$$

10. A line cuts off a Δ of constant area $= k^2$ from two fixed lines, and has its extremities in the given fixed lines [of the preceding exercise]. Show that locus of its mid-point, taking the given lines as axes, is the hyperbola

$$4xy = k^2.$$

Also show that the locus of the centroid of the Δ is the hyperbola

$$xy = \frac{k^2}{9 \sin \phi}.$$

11. Show that the asymptotes of the hyperbola in Ex. 9 are

$$\left. \begin{aligned} \frac{y}{x} &= -\sec \phi + \tan \phi, \\ \frac{y}{x} &= -\sec \phi - \tan \phi. \end{aligned} \right\}$$

12. Show that the locus of poles of normal chords of the hyperbola $x^2 - y^2 = a^2$, is the curve,

$$a^2 (y^2 - x^2) = 4x^2y^2.$$

13. A line has its extremities in two fixed rectangular axes and passes through a fixed point. Show that the locus of its mid-point is an hyperbola.

Ans. $2xy = hy + kx$, where (h, k) is fixed point given.

14. Find the equation of a tangent to the hyperbola $xy = hx + ky$ at (x_1, y_1) .

15. The polar of one end of a diameter of an hyperbola, with regard to its conjugate hyperbola, is the tangent at the other end of the given diameter.

16. The distance of any point from the center of a rectangular hyperbola varies inversely as the distance of its polar from the center.

17. In an equilateral hyperbola, lines from any point of the curve to the extremities of a diameter make equal angles with the asymptotes.

18. Show that the line $y = mx + \frac{p}{m}$ will touch the hyperbola

$$\frac{x^2}{a^2} - \frac{y^2}{b^2} = 1,$$

if

$$p^2 = m^2 (a^2m^2 - b^2).$$

Hence, find the equation of the common tangent to the two curves.

19. The parts of any chord of an hyperbola intercepted between the curve and its conjugate are equal.

20. Show that the foci of the hyperbola $xy = k^2$ are the points

$$\left[\pm k \sec \frac{\phi}{2}, \pm k \sec \frac{\phi}{2} \right]$$

where ϕ is \angle between axes [asymptotes].

166. The portions of any secant of an hyperbola intercepted between the curve and the asymptotes are equal.

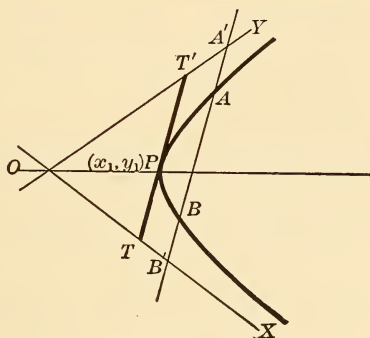

Fig. 130.

To prove $AA' = BB'$. Let A be (x_1, y_1) , B (x_2, y_2) . Then the chord AB meets the [axes] asymptotes in $B'(x_1 + x_2, 0)$ and $A'(0, y_1 + y_2)$.

Hence, the mid-point of AB coincides with that of $A'B'$.
 \therefore , etc.

167. The intercept of any tangent, between the asymptotes, is bisected at the point of contact. — Let P (x_1, y_1) be the point of contact. Then the equation of the tangent $T'T'$ is

$$\frac{x}{x_1} + \frac{y}{y_1} = 2.$$

Its intercepts on the axes are $2x_1, 2y_1$. Hence the mid-point is (x_1, y_1) ; *i.e.*, the point of contact.

\therefore , etc.

168. The area of the triangle formed by any tangent and asymptotes is constant. —

$\triangle TOT' = \frac{1}{2} OT \cdot OT' \sin 2\phi$, where 2ϕ is the angle between the asymptotes [axes].

$$= 4x_1 y_1 \sin \phi \cos \phi \quad [\S 167]$$

$$= (a^2 + b^2) \sin \phi \cos \phi$$

$$= (a^2 + b^2) \cdot \frac{b}{\sqrt{a^2 + b^2}} \cdot \frac{a}{\sqrt{a^2 + b^2}}$$

$$= ab \text{ (a constant).}$$

\therefore , etc.

169. Equations referred to conjugate diameters. — These are found in a manner analogous to that in the ellipse.

$$\frac{x^2}{a_1^2} - \frac{y^2}{b_1^2} = 1 \text{ [equation of hyperbola].}$$

$$\frac{x^2}{a_1^2} - \frac{y^2}{b_1^2} = -1 \text{ [conjugate hyperbola].}$$

$$\frac{x^2}{a_1^2} - \frac{y^2}{b_1^2} = 0 \text{ [asymptotes].}$$

170. Polar Equation, referred to left-hand focus. —

$$\rho = ex + a \quad \dots \dots \dots (1)$$

$$x = \rho \cos \theta - c = \rho \cos \theta - ae \quad \dots \dots \dots (2)$$

$$\therefore \rho = \frac{a(e^2 - 1)}{e \cos \theta - 1} \text{ from (1) and (2).}$$

The discussion is left to the student.

NOTE. — ρ is positive or negative according as the point (ρ, θ) is on the right or left branch of the hyperbola.

EXERCISES.

1. Q is any point on a rectangular hyperbola, POP' any diameter. Show that the bisectors of $\angle PQP'$ are parallel to the asymptotes.

2. A tangent to an hyperbola at P meets the conjugate curve in Q and Q'. M is the mid-point of PQ, and OM meets the hyperbola in S. Prove, OQ, OS, are conjugate diameters.

3. In a rectangular hyperbola two \perp diameters are equal.

SUGGESTION. — Show they are conjugate.

4. If two tangents are drawn from an external point, they will touch the same or opposite branches of the curve according as the point lies between or outside the asymptotes.

5. The latus rectum of an hyperbola is a third proportional to the two axes.

6. A rectangular hyperbola cuts the ellipse $\frac{x^2}{a^2} + \frac{y^2}{b^2} = 1$ at an angle ψ , and its asymptotes are the axes of the ellipse. Find its equation.

$$\text{Ans. } xy = \frac{a^2 b^2 \cos \psi}{\sqrt{[a^2 + b^2]^2 \sin^2 \psi + 4 a^2 b^2 \cos^2 \psi}}$$

SUGGESTION. — Assume $xy = k^2$ for required hyperbola. Find angle of intersection with ellipse. Put it equal to ψ . Determine k .

7. Q, R, are fixed points on an hyperbola; and P, a variable point on the curve. PQ, PR, meet an asymptote in G, G'. Show that GG' is constant.

8. ϕ_1 and ϕ_2 are the eccentric angles of the ends of two conjugate diameters of an hyperbola.

Prove,
$$\phi_1 + \phi_2 = \frac{\pi}{2}.$$

[See Appendix].

9. A semi-diameter of an ellipse or an hyperbola is a mean proportional between the lines drawn from the foci to the end of its conjugate diameter.

10. The director \odot of the hyperbola $xy = k^2$ is

$$x^2 + 2 xy \cos \phi + y^2 = 4 k^2 \cos \phi \text{ [}\phi \text{ is } \angle \text{bet. axes].}$$

SUGGESTION. — Show that the equation of the two tangents from the external point (x_1, y_1) is

$$[x_1 y - y_1 x]^2 + 4 k^2 (x - x_1) (y - y_1) = 0.$$

Express condition that these lines be \perp , etc.

EXERCISES ON CHAPTER IX.

1. The line $y = mx + 2k\sqrt{-m}$ is a tangent to the hyperbola $xy = k^2$ for all values of m . The point of contact is

$$\left[\frac{k}{\sqrt{-m}}, k\sqrt{-m} \right].$$

2. To draw a tangent to an hyperbola from a given external point. Construct an hyperbola, given :

3. Three of its points and the directions of its asymptotes.

4. One point, a vertex, and an asymptote.

5. Find locus of foci of a rectangular hyperbola which has a fixed center and passes through a fixed point. Also, locus of its vertices.

6. Find the locus of center of an equilateral hyperbola required to pass through two given points.

7. Find locus of centers of circles which intercept given lengths on the sides of a given angle. *Ans.* An hyperbola.

8. Given base of a Δ and difference of base $\sphericalangle s = \frac{\pi}{2}$, find locus of vertex. *Ans.* An hyperbola.

9. Given two points, A, B, find locus of P such that the bisector of $\sphericalangle APB$ may have a given direction.

10. Every chord of an hyperbola bisects the portion of one or the other asymptote included between the tangents at its extremities.

11. Find locus of foci of hyperbola, given one asymptote and one directrix.

12. Show that the sum of two focal chords of an hyperbola, which are parallel to two conjugate diameters, is $\frac{2(a^2 + b^2)}{a}$.

13. A circle meets a given rectangular hyperbola in four points. If one of the common chords is a diameter of the circle, prove that another is a diameter of the hyperbola.

14. ABC is a given right Δ , hypotenuse AB. A series of parabolas have AB for a common chord, while their axes are parallel to AC. Prove that all their foci lie on an hyperbola whose foci are A and B. And the hyperbola will be equilateral if ΔABC is isosceles.

15. An hyperbola has a given focus, and intersects in a given point a line parallel to one of its asymptotes. Find the locus of its center.

16. Show that every conic passing through the intersections of two rectangular hyperbolas is a rectangular hyperbola.

17. Prove that every rectangular hyperbola which passes through the vertices of a Δ passes through its orthocenter.

18. Find the locus of the centers of rectangular hyperbolas passing through the vertices of a Δ . *Ans.* The nine-points circle of the Δ .

CHAPTER X

CONFOCAL CONICS

171. Equation of a system of confocals. — The co-ordinates of the foci of the conic

$$\frac{x^2}{a^2} + \frac{y^2}{b^2} = 1 \quad \dots \dots \dots (1)$$

are $(0, \pm \sqrt{a^2 - b^2})$. These remain unchanged if we put $a^2 - \lambda, b^2 - \lambda$, for a^2 and b^2 , respectively. Hence the equation

$$\frac{x^2}{a^2 - \lambda} + \frac{y^2}{b^2 - \lambda} = 1 \quad \dots \dots \dots (2)$$

will represent any one of a system of confocals if different values be assigned to the variable parameter λ . Also if $\lambda > b^2$ (2) will represent an hyperbola.

172. Shape of a confocal. —

Let $a^2 - b^2 = c^2, a^2 - \lambda = a_1^2, b^2 - \lambda = b_1^2$.

$\therefore a_1$ and b_1 are the semi-axes of the confocal (2), and we have also

$$a_1^2 - b_1^2 = a^2 - b^2 = c^2,$$

Then (2) may be written,

$$\frac{x^2}{a_1^2} + \frac{y^2}{b_1^2} = 1$$

or
$$\frac{x^2}{b_1^2 + c^2} + \frac{y^2}{b_1^2} = 1 \quad \dots \dots \dots (3)$$

DISCUSSION of (3) :

(a) if b_1^2 is very small and positive, $a_1^2 = c^2$ nearly, \therefore the confocal is a thin ellipse nearly coincident with the line joining its foci.

(β) If b_1^2 is very small and negative, the confocal is a thin hyperbola nearly coincident with the x -axis.

(γ) If $b_1^2 = 0$, or $\lambda = b^2$, the confocal is either a line-ellipse or a line-hyperbola.

173. Two conics of a confocal system can be drawn through a given point. — Let the confocal pass through the point (x_1, y_1) . Then,

$$\frac{x_1^2}{b_1^2 + c^2} + \frac{y_1^2}{b_1^2} = 1,$$

whence, $b_1^4 - (x_1^2 + y_1^2 - c^2)b_1^2 - y_1^2c^2 = 0$.

This is a quadratic in b_1^2 , of which the roots are both real, one positive and one negative.

∴, etc.

NOTE. — One of the confocals is an ellipse, the other an hyperbola.

174. Elliptic co-ordinates. — The confocal [§ 172] may also be written,

$$\frac{x^2}{a_1^2} + \frac{y^2}{a_1^2 - c^2} = 1;$$

and if this pass through the point (x_1, y_1) , we get

$$a_1^4 - (x_1^2 + y_1^2 + c^2)a_1^2 + x_1^2c^2 = 0 \quad \dots (4)$$

If a_1^2, a_2^2 , be the roots of this equation, we have

$$a_1^2 \cdot a_2^2 = x_1^2c^2 \quad \dots (5)$$

[By § 173] similarly, $b_1^2 \cdot b_2^2 = -y_1^2c^2$ \dots (6)
 $= (a_1^2 - c^2)(a_2^2 - c^2)$.

The semi-major-axes of the two confocals passing through a given point are called its **elliptic co-ordinates**.*

NOTE. — Equations (5) and (6) give the rectangular co-ordinates (x_1, y_1) in terms of its elliptic co-ordinates a_1 and a_2 . Also from (4), $a_1^2 + a_2^2 = x_1^2 + y_1^2 + c^2$.

* By Lamé.

EXERCISES.

1. Find the equation of the director circle of the ellipse $\frac{x^2}{a^2} + \frac{y^2}{b^2} = 1$ if the elliptic co-ordinates of any point on it are a_1, a_2 .

Ans. $a_1^2 + a_2^2 = 2a^2$.

2. Tangents are drawn to the same ellipse from a point whose elliptic co-ordinates are (a_1, a_2) . Show that the angle ψ between them is found

from the equation, $\tan \frac{1}{2} \psi = \sqrt{\frac{a^2 - a_2^2}{a_1^2 - a^2}}$
 or, $\psi = 2 \tan^{-1} \sqrt{\frac{a^2 - a_2^2}{a_1^2 - a^2}}$.

3. Two parabolas have a common focus. Find the locus of the intersection of two tangents [one to each], which cut at a constant angle.

Ans. A parabola.

4. Find the locus of the extremities of the latera-recta of two parabolas which have the same focus and a common tangent.

Ans. Two circles.

5. Two ellipses have a common focus. One revolves about this focus, while the other remains fixed. Find the locus of the intersection of their common tangents.

Ans. A circle.

175. Confocals intersect orthogonally.— Let the conics

$$\frac{x^2}{a^2} + \frac{y^2}{b^2} = 1 \dots \dots \dots (1)$$

$$\frac{x^2}{a^2 - \lambda} + \frac{y^2}{b^2 - \lambda} = 1 \dots \dots \dots (2)$$

meet in the point (x_1, y_1) . Then the tangents to these are

$$\frac{xx_1}{a^2} + \frac{yy_1}{b^2} = 1 \dots \dots \dots (3)$$

and

$$\frac{xx_1}{a^2 - \lambda} + \frac{yy_1}{b^2 - \lambda} = 1 \dots \dots \dots (4)$$

Also, since (x_1, y_1) lies on each conic, we have

$$\frac{x_1^2}{a^2} + \frac{y_1^2}{b^2} = 1,$$

$$\frac{x_1^2}{a^2 - \lambda} + \frac{y_1^2}{b^2 - \lambda} = 1.$$

By subtraction,

$$\frac{x_1^2}{a^2(a^2 - \lambda)} + \frac{y_1^2}{b^2(b^2 - \lambda)} = 0.$$

But this is evidently the condition that the tangents (3) and (4) intersect at right angles.

∴ etc.

NOTE 1. The student can easily prove this geometrically.

NOTE 2. If two confocals [whose foci are F and F'] meet in P [orthogonally], then one of the curves is an ellipse, major axis = FP + F'P; the other an hyperbola, transverse axis = FP - F'P.

NOTE 3. The elliptic co-ordinates of P are $a_1 = \frac{1}{2} [FP + F'P]$, and $a_2 = \frac{1}{2} [FP - F'P]$.

EXERCISES.

1. Show that the locus of the intersection of rectangular tangents to the confocal parabolas $y^2 = 4a(x + a)$, and $y^2 = 4b(x + b)$, is the line $x + a + b = 0$.

2. Show that the above parabolas cut orthogonally [in two points] at a finite distance, and that these points are imaginary if a and b have the same sign.

3. Tangents are drawn to a confocal system from a point in the major axis. Find the locus of the points of contact. *Ans.* A circle.

4. Given three confocal ellipses. From any point P of the outermost curve, tangents are drawn to the other two, making angles ϕ and ϕ_1 with the tangent at P.

Prove,
$$\frac{\sin \phi}{\sin \phi_1} = \text{constant.}$$

NOTE. — The other two confocals may also be hyperbolas.

5. If λ and λ_1 are the parameters of the confocals which pass through any point on the directrix of the ellipse $\frac{x^2}{a^2} + \frac{y^2}{b^2} = 1$,

prove,
$$\lambda\lambda_1 = a^2(\lambda + \lambda_1).$$

6. Two conics have one focus in common. Prove that two of their common chords pass through the intersection of their directrices.

176. To find the locus of a pole of a given line with respect to a system of confocals. — Let the given line be

$$\frac{x}{h} + \frac{y}{k} = 1 \dots \dots \dots (1)$$

Now, if (x_1, y_1) is the pole of (1) with respect to

$$\frac{x^2}{a^2 - \lambda} + \frac{y^2}{b^2 - \lambda} = 1 \dots \dots \dots (2)$$

its polar is

$$\frac{xx_1}{a^2 - \lambda} + \frac{yy_1}{b^2 - \lambda} = 1 \dots \dots \dots (3)$$

Now, the condition that (1) and (3) may represent the same line is

$$\frac{1}{h} = \frac{x_1}{a^2 - \lambda} \dots \dots \dots (4)$$

and

$$\frac{1}{k} = \frac{y_1}{b^2 - \lambda} \dots \dots \dots (5)$$

From (4) and (5), we find for the required locus [after dropping accents], the line,

$$hx - ky = a^2 - b^2,$$

which is evidently \perp to the given line.

177. There is one conic and only one of a confocal system which can be drawn tangent to a given line. — Let the given line be $y = mx + c$. Its points of intersection with

$$\frac{x^2}{a^2 - \lambda} + \frac{y^2}{b^2 - \lambda} = 1$$

is determined by

$$\frac{x^2}{a^2 - \lambda} + \frac{(mx + c)^2}{b^2 - \lambda} = 1 \dots \dots \dots (1)$$

We may now write the condition that (1) may have equal roots; *i.e.*, that the given line may be a tangent. This gives an equation of the first degree in λ , hence λ can only have one value.
 \therefore , etc.

Or, if the given line be

$$x \cos a + y \sin a = p,$$

the condition that it touch the conic

$$\frac{x^2}{a^2 - \lambda} + \frac{y^2}{b^2 - \lambda} = 1$$

is $(a^2 - \lambda) \cos^2 a + (b^2 - \lambda) \sin^2 a = p^2$. [§ 134.]

This gives also, an expression of the first degree in λ .
 \therefore , etc.

NOTE 1. — In § 176, there is one conic of the confocal system which touches the given line. If this conic be determined, the point of contact is found to lie on the locus found in § 176. Hence the required locus of § 176 is the normal to this conic at the point of contact.

NOTE 2. — If the tangent at a point P of a conic, cut a confocal in A and B, the tangents at A and B intersect on the normal at P.

EXERCISES.

1. Tangents are drawn to an ellipse from a point whose elliptic coordinates are a_1 and a_2 . Also, normals are drawn to the two confocals through the given point [from that point]. Find the equation of the tangents referred to these normals as axes.

$$\text{Ans. } \frac{x^2}{(a_1^2 - a^2)} + \frac{y^2}{(a_2^2 - a^2)} = 0.$$

2. A circle is described with the focus F of a conic as center. A line through F meets the circle in P and the conic in Q. Show that the tangents at P and Q meet on a common chord of the conic and circle.

178. To find the locus of the intersection of tangents to two confocals, if these tangents meet at right angles.

$$\text{The tangent to } \frac{x^2}{a^2} + \frac{y^2}{b^2} = 1$$

$$\text{is } y - mx = \sqrt{m^2 a^2 + b^2} \quad \dots \dots \dots (1)$$

The tangent to the confocal

$$\frac{x^2}{a^2 - \lambda} + \frac{y^2}{b^2 - \lambda} = 1$$

is $y - m_1x = \sqrt{m_1^2(a^2 - \lambda) + (b^2 - \lambda)}$;
 and if this be \perp to (1), $m_1 = -\frac{1}{m}$, and its equation becomes

$$my + x = \sqrt{(a^2 - \lambda) + m^2(b^2 - \lambda)} \quad \dots \quad (2)$$

Squaring and adding (1) and (2), we obtain the required locus; viz.,

$$x^2 + y^2 = a^2 + b^2 - \lambda.$$

NOTE. — This may also be found by the method of § 134. The equations of the tangents then are

$$x \cos a + y \sin a = \sqrt{a^2 \cos^2 a + b^2 \sin^2 a}$$

and $-x \sin a + y \cos a = \sqrt{(a^2 - \lambda) \cos^2 a + (b^2 - \lambda) \sin^2 a}.$

Then square each and add to eliminate a .

EXERCISES.

1. Prove that the square of the semi-diameter of an ellipse

$$\left[\frac{x^2}{a^2} + \frac{y^2}{b^2} = 1 \right]$$

parallel to a tangent at its intersection with the confocal

$$\frac{x^2}{a^2 - \lambda} + \frac{y^2}{b^2 - \lambda} = 1 \text{ is } \lambda.$$

2. Find the confocal hyperbola through a point on the ellipse whose eccentric angle is ψ .

$$Ans. \frac{x^2}{\cos^2 \psi} - \frac{y^2}{\sin^2 \psi} = a^2 - b^2.$$

179. If d_1 and d_2 are \perp s from the center on parallel tangents to the confocals

$$\frac{x^2}{a^2} + \frac{y^2}{b^2} = 1$$

and

$$\frac{x^2}{a^2 - \lambda} + \frac{y^2}{b^2 - \lambda} = 1,$$

then

$$d_1^2 - d_2^2 = \text{a constant.}$$

Let the parallel tangents be

$$x \cos a + y \sin a = p,$$

$$x \cos a + y \sin a = p_1,$$

$$\begin{aligned} \text{then, } d_1^2 &= [p^2] = a^2 \cos^2 a + b^2 \sin^2 a, \\ d_2^2 &= [p_1^2] = (a^2 - \lambda) \cos^2 a + (b^2 - \lambda) \sin^2 a. \\ \therefore d_1^2 - d_2^2 &= \lambda \text{ (a constant).} \end{aligned}$$

EXERCISES.

1. Parallel tangents are drawn to a confocal system. Show that the locus of the points of contact is a rectangular hyperbola.

2. TP and TQ are tangents to two confocals and meet at right angles. Prove that the line joining T and the center bisects PQ.

NOTE. — Points on two ellipses which have the same eccentric angle are called **corresponding points**. Thus, $(a \cos \psi, b \sin \psi)$ and $(a_1 \cos \psi, b_1 \sin \psi)$ are corresponding points on the ellipses

$$\frac{x^2}{a^2} + \frac{y^2}{b^2} = 1, \text{ and } \frac{x^2}{a_1^2} + \frac{y^2}{b_1^2} = 1.$$

3. [Ivory's theorem.] P and Q are any two points on an ellipse, and p, q, the corresponding points on a confocal. Prove $Pq = Qp$.

4. Prove that the corresponding points on a system of confocal ellipses lie on an hyperbola.

5. Given the focus and directrix of a conic, show that the polar of a given point with respect to it passes through a fixed point.

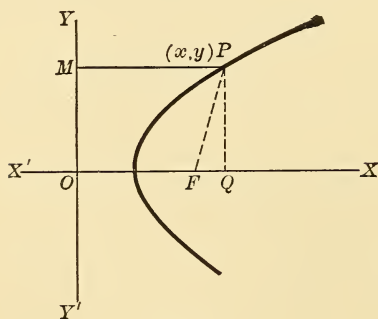

Fig. 131.

180. General equation of a conic. — *

Let P (x, y) be any point on the curve. Eccentricity = e , F is the focus, YY' the directrix. Take YY' and OF \perp to it as axes. Let OF = a .

$$\text{Now, } FP = e \cdot PM = ex,$$

$$PQ = y,$$

$$FQ = x - a.$$

* NOTE. — This and the following § should be omitted until the student has read the next chapter.

Also,

$$\overline{FP}^2 = \overline{PQ}^2 + \overline{FQ}^2$$

or,

$$e^2x^2 = y^2 + (x - a)^2.$$

$$\therefore (1 - e^2)x^2 + y^2 - 2ax + a^2 = 0 \quad \dots \quad (1)$$

DISCUSSION. — Compare (1) with the general equation of the second degree.

$$\therefore \Sigma = 1 - e^2.$$

$$\Delta = a^2e^2.$$

(1) Now [when the focus is not on the directrix, and $\Delta \neq 0$],

(a) If $e < 1$, $\Sigma > 0$, \therefore the conic is an ellipse.

(b) $e = 1$, $\Sigma = 0$, \therefore the conic is a parabola.

(c) $e > 1$, $\Sigma < 0$, \therefore the conic is an hyperbola.

(2) [When focus lies on directrix, and $\Delta = 0$.]

(a) If $e < 1$, $\Sigma > 0$, \therefore conic is a point $(0, 0)$.

(b) $e = 1$, $\Sigma = 0$, \therefore a straight line.

(c) $e > 1$, $\Sigma < 0$, \therefore two intersecting straight lines.

QUERY. — What does equation (1) represent if $e = 0$?

181. Equation of a conic through given points. — The general equation of the second degree, viz.,

$$Ax^2 + 2Hxy + By^2 + 2Gx + 2Fy + C = 0,$$

contains five arbitrary constants.

(1) Hence a conic can be found which shall pass through five given points, since each point gives one relation between those constants. If, however, three of the given points are collinear, the conic reduces to two straight lines.

(2) If a parabola is required, we have $AB - H^2 = 0$. Hence, only four additional relations are necessary; *i.e.*, a parabola can be drawn through any four points, provided no three are collinear.

(3) If a circle, $A = B$, $H = 0$, \therefore a circle can be drawn through any three points not collinear.

(4) If a pair of straight lines, $\Delta = 0$, hence they can be drawn through any four points.

EXERCISES FOR ADVANCED STUDENTS.

1. Two conics have a focus F in common. A variable line through F meets the conics in P and Q . Prove that the locus of the intersection of tangents at P and Q is a straight line.

2. Tangents at A, B, C , to a parabola $y^2 = 4ax$ [focus at F], form a triangle. If R is the radius of its circumscribed circle,

Prove,
$$R^2 = \frac{FA \cdot FB \cdot FC}{4a}.$$

3. Find the locus of the intersection of \perp tangents to the confocal parabolas

$$\left. \begin{aligned} y^2 &= 4a_1(x + a_1), \\ y^2 &= 4a_2(x + a_2). \end{aligned} \right\}$$

Ans. The straight line, $x + a_1 + a_2 = 0$.

4. Show that the equation,

$$c \tan^2 a = r (\sec a + \cos \theta),$$

where a is a variable parameter, represents a system of confocals.

5. If a point move on the director circle of the ellipse $\frac{x^2}{a^2} + \frac{y^2}{b^2} = 1$, its polar envelops, *i. e.*, always touches, the confocal.

$$\left[\frac{x^2}{\sqrt{a^2 + b^2}} \right]^2 + \left[\frac{y^2}{\sqrt{a^2 + b^2}} \right]^2 = 1.$$

6. Given a system of confocals, foci F, F' . A fixed straight line passes through the focus F , cutting the confocals. Show that the tangents to these various conics, at their points of intersection with the fixed secant, are also tangents to the parabola described with F' as focus, and the secant as directrix. Also, the portion of each tangent included between the conic and the parabola, subtends a constant angle at the focus F' .

7. Prove that the line joining the points of contact of two \perp tangents to the confocals whose semi-axes are (a_1, b_1) and (a_2, b_2) respectively, envelops the confocal whose semi-axes are

$$\left[\frac{a_1 \cdot a_2}{\sqrt{a_1^2 + b_2^2}}, \frac{b_1 \cdot b_2}{\sqrt{a_1^2 + b_2^2}} \right].$$

8. Show that an equilateral hyperbola, confocal to an ellipse, intercepts on the sides of a right angle circumscribed about the ellipse, two chords which are equal.

9. Given two confocal ellipses. From any point P tangents are drawn to one of them, and meeting the other, one in A, B, the second in C, D,

Prove,
$$\frac{1}{PA} \pm \frac{1}{PB} = \frac{1}{PC} \pm \frac{1}{PD}.$$

10. Find the condition that the two conics,

$$\left. \begin{aligned} A_1 x^2 + 2 H_1 xy + B_1 y^2 &= 1, \\ A_2 x^2 + 2 H_2 xy + B_2 y^2 &= 1, \end{aligned} \right\}$$

may be placed so as to be confocal.

Ans.
$$\frac{(A_1 - B_1)^2 + 4 H_1^2}{(A_1 B_1 - H_1^2)^2} = \frac{(A_2 - B_2)^2 + 4 H_2^2}{(A_2 B_2 - H_2^2)^2}.$$

CHAPTER XI

THE GENERAL EQUATION OF THE SECOND DEGREE

182. We have seen that the equations of the conic sections and the circle are all of the second degree, whether the axes of reference be rectangular or oblique. In this chapter we shall show that the general equation of the second degree represents a conic or some special case, by transforming coordinates, and reducing it to one of the special forms, wherein its locus becomes easily recognizable.

Let the general equation be written,

$$Ax^2 + 2Hxy + By^2 + 2Gx + 2Fy + C = 0 \quad . \quad . \quad (1)$$

The condition that (1) should represent a pair of straight lines was found in [§ 48], viz., $\Delta = 0$.

183. Condition for a central conic.—If (1) represents a central conic, the terms in x and y should vanish when the origin is transferred to the center. For if (x, y) is a point on the curve [referred to its center], then $(-x, -y)$ is also a point on the curve. But only equations of the second degree can be satisfied by equal and opposite values of (x, y) . Hence, the transformed equation cannot contain any terms in x and y .

184. Transformation to center.—Let (x_1, y_1) be the center. Then, transforming to parallel axes through (x_1, y_1) , equation (1) becomes,

$$A(x + x_1)^2 + 2H(x + x_1)(y + y_1) + B(y + y_1)^2 + 2G(x + x_1) + 2F(y + y_1) + C = 0,$$

or, $Ax^2 + 2Hxy + By^2 + 2x(Ax_1 + Hy_1 + G) + 2y(Hx_1 + By_1 + F) + C_1 = 0 \dots (2)$

[where $C_1 = Ax_1^2 + 2Hx_1y_1 + By_1^2 + 2Gx_1 + 2Fy_1 + C$] (3)

The new origin will \therefore be at the center if

$$\left. \begin{aligned} Ax_1 + Hy_1 + G &= 0 \\ Hx_1 + By_1 + F &= 0 \end{aligned} \right\} \dots (4)$$

whence, $x_1 = \frac{HF - BG}{AB - H^2}, \quad y_1 = \frac{GH - AF}{AB - H^2}.$

Hence the curve has a center if $AB - H^2 \neq 0$. This expression is usually denoted by the symbol Σ (sigma). If $\Sigma = 0$, the center is infinitely distant from the origin; *i.e.*, there is no center.

Also, from (3) the value of C_1 may be written,

$$C_1 = x_1(Ax_1 + Hy_1 + G) + y_1(Hx_1 + By_1 + F) + Gx_1 + Fy_1 + C,$$

or $C_1 = Gx_1 + Fy_1 + C$ [from equations (4)].

$$\begin{aligned} \therefore C_1 &= G \cdot \frac{HF - BG}{AB - H^2} + F \cdot \frac{GH - AF}{AB - H^2} + C \\ &= \frac{ABC + 2FGH - \overline{AF}^2 - \overline{BG}^2 - CH^2}{AB - H^2} \\ &= \frac{\Delta}{\Sigma}. \end{aligned}$$

\therefore equation (1) [*i.e.*, the conic referred to its center but not to its own axes] becomes,

$$Ax^2 + 2Hxy + By^2 + \frac{\Delta}{\Sigma} = 0 \dots (5)$$

185. Equation of conic referred to its own axes.—To find this, we must revolve the present axes through an angle θ , such that the term in xy of equation (5) will vanish. Now put

and $\left. \begin{aligned} x \cos \theta - y \sin \theta, & \text{ for } x \\ x \sin \theta + y \cos \theta, & \text{ for } y \end{aligned} \right\} \text{ in equation (5).}$

The result is, $Lx^2 + Mxy + Ny^2 + \frac{\Delta}{\Sigma} = 0$ (6)

where $L = A \cos^2 \theta + B \sin^2 \theta + 2H \sin \theta \cos \theta$. . . (7)

$N = A \sin^2 \theta + B \cos^2 \theta - 2H \sin \theta \cos \theta$. . . (8)

$M = 2(B - A) \sin \theta \cos \theta + 2H(\cos^2 \theta - \sin^2 \theta)$ (9)

Now put $M = 0$, $\therefore (A - B) \sin 2\theta - 2H \cos 2\theta = 0$.

$$\therefore \tan 2\theta = \frac{2H}{A - B} \text{ (10)}$$

Hence, if the axes of reference for equation (5) be turned through an angle θ , determined by the equation

$$\tan 2\theta = \frac{2H}{A - B},$$

the term in xy will disappear, and the equation of the curve referred to its own axes through the center becomes

$$Lx^2 + Ny^2 + \frac{\Delta}{\Sigma} = 0 \text{ (11)}$$

from which the curve may be constructed. \therefore the general equation of the second degree represents a conic.

L and N can be determined in terms of A, B, H . Thus, from (7) and (8),

$$L + N = A + B,$$

$$L - N = (A - B) \cos 2\theta + 2H \sin 2\theta,$$

which may be further reduced, finally yielding the result,

$$L \cdot N = AB - H^2 = \Sigma.$$

Hence, the curve is an ellipse or hyperbola according as L and N have like or unlike signs, provided $\frac{\Delta}{\Sigma}$ is positive. This work is, however, unnecessary to the construction of the locus of equation (11).

NOTE. — Observe that the equations found at the various steps of the transformation are also of the second degree.

186. Determination of the kind of conic.— In the general equation,

$$Ax^2 + By^2 + 2 Hxy + 2 Gx + 2 Fy + C = 0,$$

put $\rho \cos \theta$ for x , $\rho \sin \theta$ for y , obtaining

$$\rho^2 \{ A \cos^2 \theta + 2 H \cos \theta \sin \theta + B \sin^2 \theta \} + 2 \rho \{ G \cos \theta + F \sin \theta \} + C = 0.$$

One root of this quadratic in ρ is infinite if the coefficient of $\rho^2 = 0$.

$$\therefore, A \cos^2 \theta + 2 H \sin \theta \cos \theta + B \sin^2 \theta = 0,$$

or, $A + 2 H \tan \theta + B \tan^2 \theta = 0,$

which is the equation determining the lines through the origin meeting the curve at infinity; or, putting $\frac{y}{x}$ for $\tan \theta$, we get,

$$Ax^2 + 2 Hxy + By^2 = 0.$$

These lines are real if $H^2 - AB > 0$, hence in this case the general equation represents an hyperbola, and the lines are parallel to the asymptotes.

They are imaginary if $H^2 - AB < 0$; hence in this case the curve is an ellipse.

They coincide if $H^2 - AB = 0$; hence in this case the curve is a parabola.

Both roots of the above quadratic are infinite if also $G = 0$, and $F = 0$.

Hence, the asymptotes of the conic

$$Ax^2 + 2 Hxy + By^2 + C = 0,$$

are $Ax^2 + 2 Hxy + By^2 = 0.$

NOTE.—The asymptotes of an ellipse are imaginary, viz.,

$$\frac{x^2}{a^2} + \frac{y^2}{b^2} = 0,$$

or, $\frac{x}{a} \pm \frac{y\sqrt{-1}}{b} = 0.$

187. Condition for a rectangular hyperbola.—The equation

$$Ax^2 + 2Hxy + By^2 = 0$$

represents, as we have seen, a pair of straight lines parallel to the asymptotes of the general equation. Now, if the latter be a rectangular hyperbola, the asymptotes, and \therefore the two lines given, are \perp to each other; hence $A + B = 0$.

[See § 46].

188. The asymptotes of a conic.—The equation

$$Ax^2 + 2Hxy + By^2 + 2Gx + 2Fy + C + \lambda = 0$$

represents the asymptotes of the general equation if

$$\begin{vmatrix} A & H & G \\ H & B & F \\ G & F & C + \lambda \end{vmatrix} = 0,$$

or $\lambda \cdot \Sigma + \Delta = 0$.

Hence, if $S = 0$ denote the general equation, its asymptotes are

$$S = \frac{\Delta}{\Sigma}.$$

And since the conjugate hyperbola is $S + 2\lambda = 0$, its asymptotes are

$$S = \frac{2\Delta}{\Sigma}.$$

189. The axes of a conic.—The equation,

$$\tan 2\theta = \frac{2H}{A - B},$$

may be written thus:

$$H(1 - \tan^2 \theta) = (A - B) \tan \theta;$$

or, putting $\frac{y}{x}$ for $\tan \theta$, we get,

$$H(x^2 - y^2) = (A - B)xy,$$

which is evidently the equation of the axes of the conic.

190. Tangent, diameter, and polar at (x_1, y_1) . — These are worked out in precisely the same manner as in previous chapters, the results being :

(1) A tangent at (x_1, y_1) is

$$Axx_1 + H(xy_1 + x_1y) + Byy_1 + G(x + x_1) + F(y + y_1) + C = 0.$$

(2) A diameter is

$$Ax + Hy + G + m(Hx + By + F) = 0,$$

where m is the slope of the given chord.

(3) The polar of (x_1, y_1) is the same as the equation of the tangent.

NOTE. — (1), (2), and (3) hold whether the axes be rectangular or oblique. Also, the remarks concerning polars in previous chapters are applicable here.

191. Conjugate diameters. — If the above diameter be parallel to $y = m_1x$, we have,

$$m_1 = -\frac{A + Hm}{H + Bm};$$

or,

$$Bmm_1 + H(m + m_1) + A = 0$$

is the condition existing if $y = mx$ and $y = m_1x$ are parallel to two conjugate diameters.

NOTE. — The polar of the origin is

$$Gx + Fy + C = 0.$$

192. Condition that two given lines may be conjugate diameters of a given conic. — Let the given lines be,

$$ax^2 + 2hxy + by^2 = 0,$$

and the given conic $Ax^2 + 2Hxy + By^2 + C = 0$.

Suppose the given lines be written,

$$b(y - mx)(y - m_1x) = 0 \dots \dots (1)$$

$$\therefore m + m_1 = -\frac{2h}{b}, \text{ and } mm_1 = \frac{a}{b}.$$

Now, the lines (1) are conjugate diameters of the given conic if

$$Bmm_1 + H(m + m_1) + A = 0$$

$$\therefore B\frac{a}{b} - 2H\frac{h}{b} + A = 0,$$

or the required condition is

$$Ab + Ba - 2Hh = 0.$$

193. Summary of the discussion of the general equation of the second degree. — We here recapitulate the loci represented by the general equation, for the various conditions among its coefficients. Three typical examples are worked out briefly to show the method of procedure in constructing the locus.

Σ	Δ	Locus.
> 0	$\neq 0$	An ellipse. [A circle when $A = B$ and $H = 0$.]
	> 0	Imaginary.
	< 0	Real.
	$= 0$	A pair of imaginary straight lines or a point.
$= 0$	$\neq 0$	A parabola.
	$= 0$	Two parallel straight lines or one straight line, or no locus.
< 0	$\neq 0$	An hyperbola.
	$= 0$	If $A + B = 0$, a rectangular hyperbola. A pair of real intersecting straight lines.

NOTE. — Several minor details which the student can discover for himself in working examples, are not given here.

EXAMPLE 1. Trace the conic.

$$5x^2 + 6xy + 5y^2 - 16x - 16y + 8 = 0.$$

Here $\Sigma = 16$, $\Delta < 0$, \therefore an ellipse.

Center is found to be the point (1, 1). The equation referred to parallel axes through the center is

$$5x^2 + 6xy + 5y^2 - 8 = 0,$$

$$\tan 2\theta = \frac{2H}{A-B} = \frac{6}{0} = \infty, \therefore \theta = 45^\circ.$$

Turning axes through 45° , the equation of the ellipse referred to its own axes is

$$x^2 + 4y^2 = 4,$$

or,

$$\frac{x^2}{(2)^2} + \frac{y^2}{(1)^2} = 1.$$

\therefore semi-axes are 2 and 1.

The curve is shown in the figure.

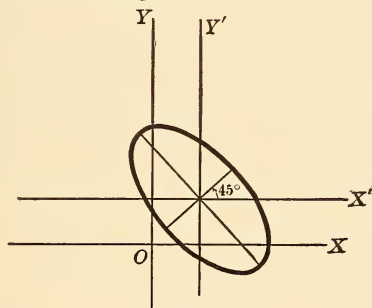

Fig. 132.

Ex. 2. Trace the locus

$$4x^2 + 4xy + y^2 - 18x + 26y + 64 = 0.$$

Here $\Sigma = 0$, $\Delta \neq 0$, \therefore a parabola.

$$\tan 2\theta = \frac{2H}{A-B} = \frac{4}{3} = \frac{2 \tan \theta}{1 - \tan^2 \theta}.$$

$\therefore \tan \theta = -2$.

Hence, if the axes are turned through $\tan^{-1}(-2)$, the new equation will be,

$$\left(y + \frac{8}{5}\right)^2 = 4 \cdot \frac{14}{4\sqrt{5}} \left(x - \frac{13}{10}\right).$$

Hence, vertex is point $\left(\frac{13}{10}, -\frac{8}{5}\right)$, latus rectum $= 4 \cdot \frac{14}{4\sqrt{5}} = \frac{14}{\sqrt{5}}$.

Similarly, the focus is found to be the point $(2, -3)$, and the directrix the line $x - 2y = 1$.

The curve is shown in the figure.

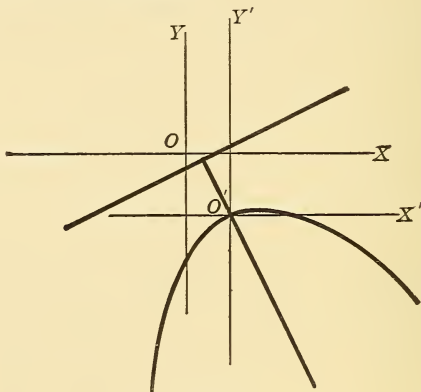

Fig. 133.

Ex. 3. Trace the conic

$$4x^2 - 24xy + 11y^2 + 40x + 30y - 105 = 0.$$

$$\Sigma = AB - H^2 = 44 - (-12)^2 = -100, \Delta \neq 0,$$

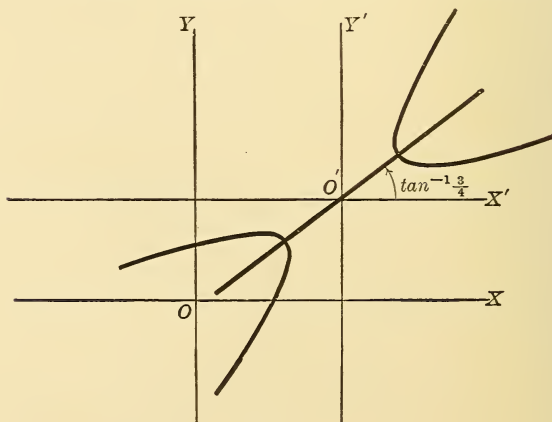

Fig. 134.

$$\therefore \text{an hyperbola.} \quad \therefore \tan \theta = \frac{3}{4},$$

$$\tan 2\theta = \frac{2H}{A-B} = \frac{-24}{-7} = \frac{24}{7}.$$

The center is (4, 3), and the equation referred to parallel axes through the center is

$$4x^2 - 24xy + 11y^2 + 20 = 0.$$

Turning the axes through $\tan^{-1} \frac{3}{4}$, we get the equation of the hyperbola referred to its own axes, viz.,

$$\frac{x^2}{4} - \frac{y^2}{1} = 1.$$

Hence, semi-axes are 2 and 1.

The curve is shown in the figure.

EXERCISES ON CHAPTER XI.

Trace the following loci:

1. $4(x-y)^2 = 4(x+y) - 1.$ *Ans.* Parabola.
2. $x^2 + xy + y^2 - 3x - 3y = 0.$
Ans. Ellipse, $\theta = 135^\circ$, semi-axes $\sqrt{6}$, $\sqrt{2}$.
3. $2x^2 - 3x - 4y - 5 = 0.$ *Ans.* Parabola.
4. $6x^2 - xy - y^2 - x + 3y + 2 = 0.$ *Ans.* Hyperbola.
5. $y^2 - 3x - 4y = 0.$ *Ans.* Parabola.
6. $5x^2 + 11xy + 2y^2 - 13x + 10y - 28 = 0.$
Ans. Two intersecting lines.
7. $(x-y)^2 - 4 - x^2 = 0.$
8. $2x^2 - 2xy + y^2 - 2y = 0.$ *Ans.* Ellipse.
9. $5x^2 + 4xy + 8y^2 - 18x - 36y + 9 = 0.$
Ans. Ellipse, $\theta = \tan^{-1}(-\frac{1}{2})$, semi-axes 3 and 2.
10. $(x-2y)^2 - 2(x+2y) + 1 = 0.$ *Ans.* Parabola.
11. $xy - bx - ay = 0.$
Ans. Hyperbola, $\theta = 45^\circ$, semi-axes $(\sqrt{2ab})$, $(\sqrt{2ab})$.
12. $(3x+4y)^2 + 22x + 46y + 9 = 0.$
Ans. Parabola, latus rectum = $\frac{2}{3}$.
13. $6x^2 - xy - y^2 - x + 3y - 2 = 0.$ *Ans.* Two straight lines.
14. $4x^2 - 4xy + y^2 + 8x - 4y = 0.$ *Ans.* Two parallel lines.

15. $3x^2 + 2y^2 - 2x + y - 1 = 0.$ *Ans.* Ellipse.

16. $x^2 + 2xy - y^2 + 8x + 4y - 8 = 0.$ *Ans.* Hyperbola.

17. $\sqrt{x} + \sqrt{y} = \sqrt{a}\sqrt{b}.$

Ans. Parabola referred to tangents at extremities of latus rectum $[4a].$

18. $\sqrt{\frac{x}{a}} + \sqrt{\frac{y}{b}} = 1.$ *Ans.* Parabola, latus rectum = $\frac{4a^2b^2}{[a^2 + b^2]^{\frac{3}{2}}}.$

19. Find the center of the conic

$$Ax^2 + 2Hxy + By^2 - 2y = 0.$$

Ans. $\left(\frac{H}{H^2 - AB}, \frac{-A}{H^2 - AB} \right).$

Trace the conics.

20. $(A^2 + B^2)(x^2 + y^2) = (Bx + Ay - AB)^2.$

Ans. Parabola, latus rectum = $\frac{2AB}{\sqrt{A^2 + B^2}}.$

21. $xy - x^2 - a^2 = 0.$ *Ans.* Hyperbola. Product of semi-axes = $2a^2.$

22. $\sqrt{x} + \sqrt{y} = 3.$ *Ans.* Parabola, latus rectum = $3\sqrt{2}.$

23. Find the condition that the four points of intersection of the conics

$$\left. \begin{aligned} A_1x^2 + 2H_1xy + B_1y^2 &= 1, \\ A_2x^2 + 2H_2xy + B_2y^2 &= 1, \end{aligned} \right\}$$

may be concyclic.

Ans. $(A_1 - B_1)H_2 = (A_2 - B_2)H_1.$

24. The major axes of two conics are parallel. Show that their four points of intersection are concyclic.

25. Show that the eccentricity of the conic

$$Ax^2 + 2Hxy + By^2 + 2Gx + 2Fy + C = 0$$

is determined from the equation

$$\left[\frac{e^2}{2 - e^2} \right]^2 = \frac{[A - B]^2 + 4H^2}{[A + B]^2}.$$

26. Show that the equation of a conic referred to an axis and the tangent at the vertex is

$$y^2 = px + qx^2,$$

and is

(1) a parabola, if $q = 0;$

(2) an hyperbola, if $q > 0;$

(3) an ellipse, if $q < 0.$

REMARK. — The names parabola, ellipse, and hyperbola were originally derived from this property.

CHAPTER XII

HIGHER PLANE CURVES

194. Definitions. — A curve whose equation in Cartesian or rectilinear co-ordinates involves only algebraic functions is an **algebraic curve**. Any other curve is called a **transcendental curve**. Examples :

$$\begin{aligned}x &= \cos y, & y &= \sin^{-1} x, \\y &= \tan^{-1} x, & x &= \log_a y, \text{ etc.}\end{aligned}$$

Transcendental curves and all algebraic curves whose equations are of a higher degree than the second are known as higher plane curves. A few of these, which have become celebrated in the history of mathematics, will be examined in the present chapter.

195. The cissoid.* Definition. — AL is a tangent to the circle OFA at A, the end of the diameter OA. C is the center of the \odot . OB is any straight line from O to AL and cutting the circle in D. Take OP=BD. The locus of P as OB revolves about O, is the cissoid. To find its equation, take OX and OY \perp to it as axes. Let P be (x, y) and the radius CA of the circle equal to a .

* Invented by Diocles, a Greek geometer of the second century B. C., for finding two mean proportionals between two given lines, or more specifically to "duplicate the cube"; *i. e.*, to find the side of a cube whose volume shall be twice that of a given cube.

196. To duplicate the cube. — Take $CK = 2a$. Draw AK , cutting the cissoid in H . Now, since

$$CA = \frac{1}{2} CK, \quad GA = \frac{1}{2} GH.$$

But from the equation of the cissoid, we have,

$$\overline{GH}^2 = \frac{\overline{OG}^3}{GA} = \frac{\overline{OG}^3}{\frac{1}{2} GH}, \quad \therefore \overline{GH}^3 = 2 \overline{OG}^3.$$

Now, let c be the edge of any given cube, and let c_1 be required such that $c_1^3 = 2c^3$. To this end, take c_1 so that

$$\begin{aligned} OG : GH &:: c : c_1 \\ \overline{OG}^3 : \overline{GH}^3 &:: c^3 : c_1^3. \\ \overline{GH}^3 &= 2 \overline{OG}^3. \\ \therefore c_1^3 &= 2c^3. \end{aligned}$$

or
But

Hence, c_1 is the edge of a cube whose volume is double that of the given cube whose edge is c . In like manner, by taking $CK = ka$, we can find the edge of a cube k times the volume of a given cube.

197. The conchoid.* **Definition.** — Let A be a fixed point,

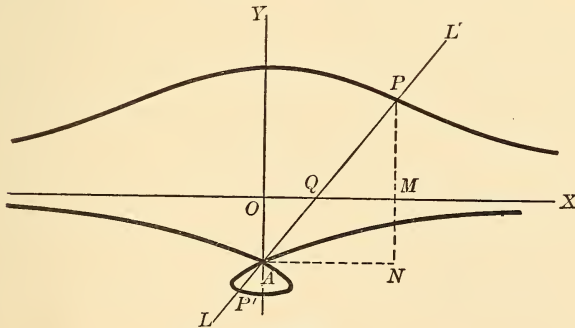

Fig. 136.

* Invented by Nicomedes, a Greek geometer of the second century B.C., for the purpose of duplicating the cube. It is, however, more easily applicable to the trisection of a given angle, which was also a famous problem of the ancients.

and OX a fixed line. A straight line LL' revolves about A , cutting OX in Q . The locus of the point P such that PQ always equals a given constant, a , is the conchoid. A is the **pole**, OX the **directrix**, and the constant distance PQ [a] is the **parameter**. To find the equation of the curve, take OX , and $OY \perp$ to it through A , as axes.

Draw $AN \parallel$ to OY and meeting the ordinate PM in N .

Let P be (x, y) . Let $AO = c$ [a known distance].

Then by similar Δ s,

$$AN : NP :: QM : MP,$$

or,
$$x : y + c :: \sqrt{a^2 - y^2} : y,$$

whence,
$$x^2 y^2 = (y + c)^2 [a^2 - y^2]$$

is the required equation.

DISCUSSION. — (1) The curve lies between the lines $y = \pm a$.

(2) It is symmetrical to the y -axis.

(3) The curve has four infinite branches to which the x -axis is an asymptote.

(4) If $c < a$, the curve has an oval or loop beneath A .

If $c = a$, the loop becomes a point at A .

If $c > a$, both portions of the curve lie above A .

If $c = 0$, the conchoid becomes a circle.

To find the polar equation of the curve, let A be the pole, AY the initial line, and P or P_1 (ρ, θ).

Then,
$$\rho = AP = AQ \pm QP$$

$$= OA \sec \theta \pm QP.$$

$$\therefore \rho = c \sec \theta \pm a$$

is the equation required.

198. To trisect a given angle. — Let BAC be the given angle. On AB lay off AL [any length], and through L draw $LO \perp$ to AC . Now take $OC = 2AL$, and with A as pole, OX , directrix, and OC as parameter, construct a conchoid.

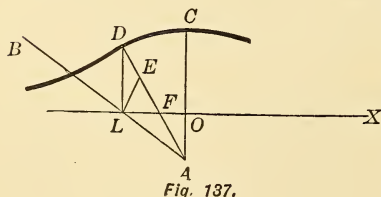

Fig. 137.

Draw $LD \perp$ to OX . Then AD cuts off a third of the given angle BAC .

Proof: Bisect DF in E . Then

$$LE = ED = \frac{1}{2} OC = AL.$$

$$\therefore \angle LAE = \angle LEA = 2 \angle LDE = 2 \angle DAC.$$

$$\therefore \angle DAC = \frac{1}{3} \angle BAC.$$

199. The lemniscate. — This curve is the locus of the foot of a perpendicular from the center of a rectangular hyperbola to a tangent to the latter curve.

To find its equation :

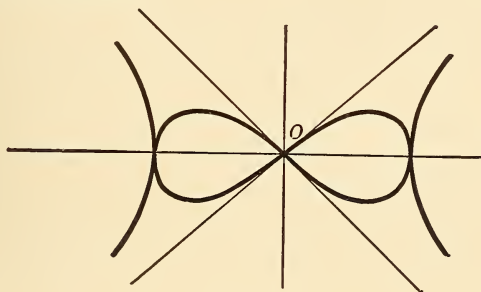

Fig. 138.

The tangent to the hyperbola $x^2 - y^2 = a^2$ at (x_1, y_1) is

$$xx_1 - yy_1 = a^2 \dots \dots \dots (1)$$

The \perp to it from the origin is

$$y = -\frac{y_1}{x_1} x,$$

or,
$$\frac{x}{x_1} = -\frac{y}{y_1} \dots \dots \dots (2)$$

Also,
$$x_1^2 - y_1^2 = a^2 \dots \dots \dots (3)$$

Eliminating (x_1, y_1) between (1), (2), and (3), we get,

$$(x^2 + y^2)^2 = a^2(x^2 - y^2),$$

which is the equation required.

DISCUSSION. — (1) The curve is symmetrical to both axes, and \therefore to the center of the hyperbola.

(2) It lies entirely between the lines $x = \pm a$.

(3) It passes through the origin or center. Its properties can be more readily seen from its polar equation. Put $x = \rho \cos \theta$, $y = \rho \sin \theta$. The result is,

$$\rho^2 = a^2 \cos 2\theta.$$

$$\therefore \rho = \pm a \sqrt{\cos 2\theta}.$$

DISCUSSION. — When $\theta = 0^\circ$ or 180° , $\rho = \pm a$. When $\theta < 45^\circ$, ρ has two equal opposite values $< a$. When $\theta = 45^\circ$, $\rho = 0$, hence the curve cuts the initial line [x -axis] at 45° .

When θ lies between 45° and 135° , ρ is imaginary. When θ lies between 135° and 180° , ρ has again two equal and opposite values $< a$.

Hence the curve consists of two ovals. Also, the asymptotes of the hyperbola are tangents to the lemniscate at O.

200. The witch.* Definition. — The line YA is a tangent to the circle whose center is C, at the end of the diameter OY. Any line OK from O to YA cuts the circle in M. If the abscissa NM of the point M be produced to P so that $NP = YK$, then the locus of P, as the line OK revolves about O, is the witch.

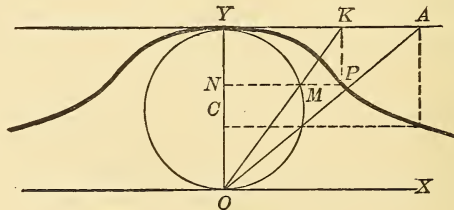

Fig. 139.

To find its equation, take OY and OX \perp to it as axes. Let $OY = 2a$, and let P be (x, y) .

* Invented by Donna Maria Agnesi (1718–1799) an Italian mathematician.

Then, by similar Δ s,

$$ON : OY :: NM : YK [= NP];$$

or,
$$y : 2a :: \sqrt{y(2a - y)} : x.$$

$$\therefore x^2y = 4a^2(2a - y)$$

is the required equation.

DISCUSSION. — (1) Curve is symmetrical to the y -axis.

(2) Lies entirely between the lines $y = 0$, $y = 2a$.

(3) It has two infinite branches to which the x -axis is an asymptote.

201. The cycloid. — This curve is traced by a point P on the circumference of a circle which rolls on a fixed line OX. This line is called the **base**, the rolling circle the **generatrix**, and P the generating point.

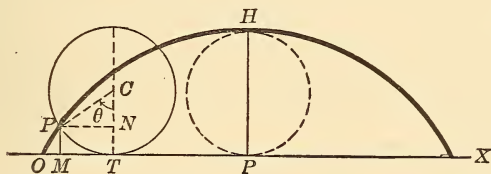

Fig. 140.

To find its equation : take OX [the base] as x -axis, and the point O where the curve begins [*i.e.*, the position of P when the circle commences to roll] as origin.

Let the radius of the circle be a and $\angle PCT = \theta$, where C is the center of the circle.

Then, arc PT = segment OT, over which the circle has rolled, and

$$\theta = \frac{\text{arc PT}}{a}, \quad \therefore \text{arc PT} = a\theta.$$

Let P, any point on the curve, be (x, y) .

Now, $x = OM = OT - TM = \text{arc PT} - PN.$

$$\therefore x = a\theta - a \sin \theta = a (\theta - \sin \theta) \quad \dots \quad (1)$$

Similarly, $y = a (1 - \cos \theta) \quad \dots \quad (2)$

To eliminate θ , we get from (2),

$$\cos \theta = \frac{a - y}{a}, \therefore \theta = \cos^{-1} \left(\frac{a - y}{a} \right) = \text{vers}^{-1} \left(\frac{y}{a} \right);$$

Also, $\sin \theta = \frac{\pm \sqrt{2ay - y^2}}{a}.$

Substituting these values in (1), we obtain

$$x = a \text{vers}^{-1} \frac{y}{a} - \sqrt{2ay - y^2},$$

which is the required equation of the cycloid.

NOTE.—Equations (1) and (2) are also taken together as the equations of the cycloid.

202. The hypocycloid.—This is the locus of a point P on the circumference of a circle which rolls on the inside of a fixed circle.

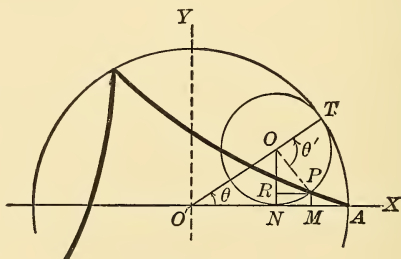

Fig. 141.

To find its equation: Take O', the center of the fixed circle, as origin, and the \perp diameters OAX, OY, as axes. Let A be the initial point of the curve.

$$\left. \begin{array}{l} \text{Radius of fixed circle} = a \\ \text{Radius of moving circle} = b \end{array} \right\} \angle OPR = \phi.$$

Let $P(x, y)$ be any point on the curve. Draw $O'T$ through the center O of the moving circle. Also the ordinates ON and PM , and PR parallel to $O'A$.

Now, arc $TP =$ arc TA [covered by moving circle].

$$\begin{aligned} x &= O'M = O'N + NM = O'N + PR \\ &= O'O \cdot \cos \theta + PO \cdot \cos \phi = O'O \cos \theta + PO \cos (\theta' - \theta). \end{aligned}$$

$$\therefore x = (a - b) \cos \theta + b \cos (\theta' - \theta);$$

but $a\theta = b\theta', \therefore \theta' = \frac{a}{b} \theta.$

$$\therefore x = (a - b) \cos \theta + b \cos \left(\frac{a - b}{b} \theta \right) \dots (1)$$

Similarly, $y = (a - b) \sin \theta - b \sin \left(\frac{a - b}{b} \theta \right) \dots (2)$

These two equations together represent the hypocycloid. A single equation can, however, be obtained by eliminating θ .

NOTE.—When the radii are commensurable, the hypocycloid is a closed curve.

203. The hypocycloid of four cusps — This is the hypocycloid generated when $a = 4b$.

Equations (1) and (2) of § 202 become,

$$x = \frac{3}{4} a \cdot \cos \theta + \frac{1}{4} a \cdot \cos 3 \theta \dots (3)$$

$$y = \frac{3}{4} a \cdot \sin \theta - \frac{1}{4} a \cdot \sin 3 \theta \dots (4)$$

But, $\cos 3 \theta = 4 \cos^3 \theta - 3 \cos \theta,$

$$\sin 3 \theta = 3 \sin \theta - 4 \sin^3 \theta.$$

\therefore (3) and (4) become

$$x = a \cos^3 \theta,$$

$$y = a \sin^3 \theta,$$

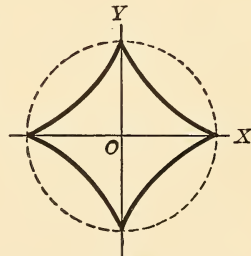

Fig. 142.

whence $x^{\frac{2}{3}} + y^{\frac{2}{3}} = a^{\frac{2}{3}}$

is the equation required.

204. The limaçon.* — If in the circle whose equation is $\rho = 2a \cos \theta$, a constant length be added to each radius vector, we get, $\rho = 2a \cos \theta + k$, which is the equation of the limaçon.

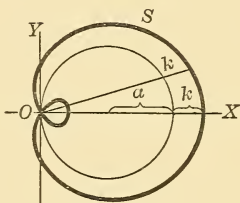

Fig. 143.

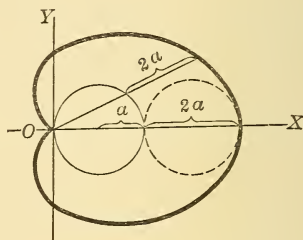

Fig. 144.

Generally we take $k = a$. $\therefore \rho = a(1 + 2 \cos \theta)$.

DISCUSSION. — The curve is symmetrical to the initial line.

The polar equation is easily transformed to rectangular co-ordinates by putting

$$\rho = \sqrt{x^2 + y^2}, \quad \sin \theta = \frac{y}{\sqrt{x^2 + y^2}}, \quad \cos \theta = \frac{x}{\sqrt{x^2 + y^2}}.$$

The result is, $(x^2 + y^2 - 2ax)^2 = a^2(x^2 + y^2)$.

SPECIAL CASE. — If $k = 2a$, the curve is called the **cardioid**. Its equation is, therefore,

$$\rho = 2a(1 + \cos \theta),$$

or,

$$\rho = 2a(1 - \cos \theta)$$

[by turning axes through π].

Its rectangular equation is,

$$(x^2 + y^2 + 2ax)^2 = a^2(x^2 + y^2).$$

205. The rose of four loops. — This curve is the locus of the foot of a \perp from the origin on a line which is of fixed length and moves with its extremities always in the axes.

* Invented by Pascal, a French philosopher (1623-62). See note 10, Appendix.

PQ is of constant length. OM is the \perp on PQ. The point M describes the rose. The \perp OM is a maximum when M falls at the mid-point of PQ. [For the altitude of a right \triangle of a constant hypotenuse is greatest when the \triangle is isosceles.]

To find its equation. Let O be the pole, OX the initial line. Then, from the right \triangle OMP and OPQ

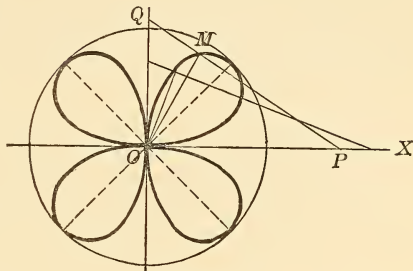

Fig. 145.

$$\rho = OP \cos \theta, \quad OP = 2a \sin \theta. \quad [2a = \text{length of PQ.}]$$

$$\therefore \rho = a \sin 2\theta$$

is the equation required.

To obtain its rectangular equation, put

$$\rho = \sqrt{x^2 + y^2}, \quad \sin \theta = \frac{y}{\rho}, \quad \cos \theta = \frac{x}{\rho}.$$

$$\text{The result is, } (x^2 + y^2)^3 - 4a^2x^2y^2 = 0.$$

[The equation is of the sixth degree].*

NOTE. — The mid-point of PQ describes a circle of radius a .

SPIRALS

206. Definition. — A spiral is the locus of a point which revolves about a fixed point or **pole**, while its radius vector and vectorial angle continually increase or continually decrease according to some law.

* The discussion of these equations is left to the student. The polar equation will more readily show the properties of the curve.

The equation $\rho = a \cos 2\theta$ represents the same curve turned through an angle of 45° , *i.e.*, its branches lying on the axes.

The portion of the curve generated in one revolution of the radius vector is called a **spire**.

The **measuring-circle** of the spiral is the circle whose center is at the pole, and whose radius is equal to the length of the radius vector at the end of the first revolution, *i.e.*, the value of ρ when $\theta = 2\pi$.

207. The spiral of Archimedes. — This curve is the locus of a point whose radius vector bears a constant ratio to the vectorial angle. The equation follows from this definition; *viz.*,

$$\rho = k \cdot \theta.$$

DISCUSSION. — The spiral passes through the pole. Also, the radius vector increases without limit as the number of revolutions increase correspondingly.

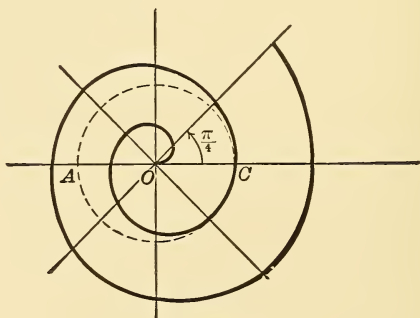

Fig. 146.

θ	0	$\frac{\pi}{4}$	$\frac{\pi}{2}$	$\frac{3}{4}\pi$	π	$\frac{5}{4}\pi$...	etc.
ρ	0	$k\frac{\pi}{4}$	$k\frac{\pi}{2}$	$k\frac{3}{4}\pi$	$k \cdot \pi$	$k\frac{5}{4}\pi$...	etc.

From the table, a definite number of spires are readily constructed. The measuring circle here is ABC, whose center is O and radius $OC = 2k\pi$. Again, the spires, being everywhere equally distant along the radial lines, are said to be "parallel." The figure shows the curve for positive values of θ .

208. The reciprocal spiral.—In this curve the radius vector varies inversely as the vectorial angle *i.e.*, as the reciprocal of the vectorial angle. Its equation is, \therefore

$$\rho = \frac{k}{\theta}, \text{ or } \rho\theta = k.$$

The curve is readily described from the following table:

θ	0	$\frac{1}{4}\pi$	$\frac{1}{2}\pi$	$\frac{3}{4}\pi$	π	$\frac{5}{4}\pi$	etc.	
ρ	∞	$8 \cdot \frac{k}{2\pi}$	$4 \cdot \frac{k}{2\pi}$	$\frac{8}{3} \frac{k}{2\pi}$	$2 \frac{k}{2\pi}$	$\frac{8}{5} \frac{k}{2\pi}$	etc.	

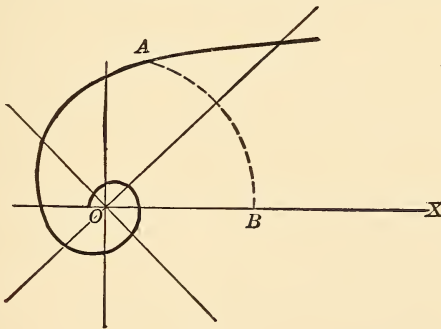

Fig. 147.

DISCUSSION.—The spiral begins at infinity [when $\theta = 0$] and winds continually around the pole, always approaching nearer and nearer but

never reaching it, or reaching it after an infinite number of spires have been described, since $\rho = 0$, when $\theta = \infty$.

The circumference of the measuring circle is k .

$$\left(\text{When } \theta = 2\pi, \rho = \frac{k}{2\pi} \therefore \text{circumference} = 2\pi \frac{k}{2\pi} = k. \right)$$

Again, since $\rho\theta = k$, the arc AB described with the radius vector of any point A is constant. The line parallel to the initial line OX and at a distance k above it is an asymptote to the infinite branch, for as ρ approaches ∞ , the arc AB becomes perpendicular to OX.

The figure shows the curve for positive values of θ .

209. The parabolic spiral. — In this curve, the square of the radius vector varies as the vectorial angle.

$$\therefore \rho^2 = k\theta$$

is its equation.

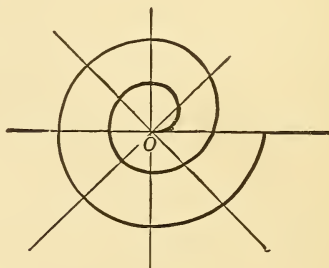

Fig. 148.

DISCUSSION. — The curve begins at the pole [when $\theta = 0$, $\rho = 0$] and winds continually around it, always receding from it. The radius vector becomes infinite after an infinite number of spires have been described.

210. The lituus. — In this curve, the square of the radius vector varies inversely as the vectorial angle. Its equation is, \therefore

$$\rho^2 = \frac{k}{\theta}.$$

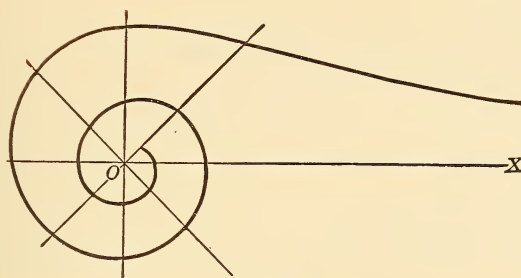

Fig. 149.

DISCUSSION. — The curve begins at infinity and winds steadily around the pole but never attains it.

$$\left[\begin{array}{l} \theta = 0, \rho = \infty. \\ \theta = \infty, \rho = 0. \end{array} \right]$$

The figure shows the curve for positive values of θ .

211. General equation of a spiral. — This may obviously be written,

$$\rho = k \cdot \theta^n \dots \dots \dots (1)$$

DISCUSSION. — When $n = 1$, equation (1) is the spiral of Archimedes,
 $n = -1$, the reciprocal spiral.
 $n = \frac{1}{2}$, the parabolic spiral.
 $n = -\frac{1}{2}$, the lituus

212. The logarithmic spiral. — In this curve, the logarithms of the radii-vectores are in the same ratio as the vectorial angles.

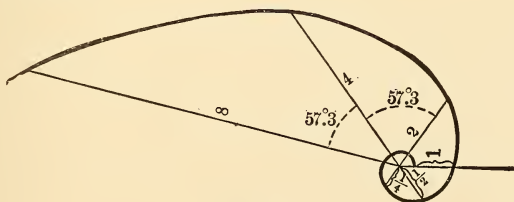

Fig. 150.

Its equation is, $\therefore \log \rho = k \theta$.

It may also be written in these forms; viz.,

$$\rho = a^\theta, \quad \theta = \log_a \rho.$$

θ	-2	-1	0	1	2	3	etc.
ρ	$\frac{1}{4}$	$\frac{1}{2}$	1	2	4	8	etc.

When $a = 2$, the table given here is readily found. [θ is expressed in radians.]

DISCUSSION. — When $\theta = -\infty$, $\rho = 0$.

$$\theta = 0, \quad \rho = 1.$$

$\therefore \rho$ varies from 0 to $+1$, when θ varies from $-\infty$ to 0, and ρ varies from $+1$ to $+\infty$, when θ varies from 0 to $+\infty$.

\therefore The number of spires is infinite.

EXERCISES ON CHAPTER XII.

1. Find the locus of a point the product of whose distances from two fixed points is constant. Take the distance between the points equal to $a\sqrt{2}$ and the constant product is $\frac{a^2}{2}$. *Ans.* The lemniscate.

2. Show that the cissoid is the locus of the foot of a perpendicular from the vertex of a parabola on a tangent to the latter. The parabola is $y^2 = -8ax$.

3. Show that the cardioid is the locus of a point on the circumference of a circle which rolls on an equal fixed circle.

4. Show that the logarithmic spiral may be defined as the locus of a point such that its radius vector increases in a geometric ratio, while the vectorial angle increases in an arithmetic ratio.

5. Construct the logarithmic curve $y = a^x$ or $x = \log_a y$. Show that every logarithmic curve passes through the point (0, 1) and has the x -axis for an asymptote.

EXERCISES FOR ADVANCED STUDENTS.

1. A variable circle touches a given fixed circle in a given point. A tangent is drawn common to the two circles. Find the locus of its point of contact with the variable circle. *Ans.* A cissoid.

2. A variable triangle whose vertex A is fixed, and $\angle A$ is constant, is inscribed in a circle. Find the locus of the centers of the circles inscribed in, and circumscribed about, the triangle. *Ans.* Two limaçons.

3. In a triangle the base a is fixed, and the other two sides b and c , and the median m to the base, always satisfy this relation, viz.,

$$b - c = m\sqrt{2}.$$

Find the locus of the vertex of the triangle. *Ans.* A lemniscate.

4. Two circles are given and a tangent to each. These tangents meet at an angle which is constant [and given]. Find the locus of its vertex.

Ans. Two limaçons.

REVIEW EXAMPLES IN PLANE ANALYTICAL GEOMETRY.

1. If A, B, C are three points on a straight line, let a, b, c be their distances from a fixed point O on the line.

Prove: $(b - a) + (c - b) + (a - c) = 0.$

SUGGESTION: $AB + BC + CA = 0.$

2. Let a, b, c, d , be the distances of any four points A, B, C, D from a fixed point O, all being on the same straight line.

Prove: $AD \cdot CB + BD \cdot AC + CD \cdot BA = 0.$

SUGGESTION:

$$(d - a)(b - c) + (d - b)(c - a) + (d - c)(a - b) \equiv 0.$$

If the points are situated in the order A, B, C, D, we have

$$CB = -BC, BA = -AB,$$

whence we obtain,

$$BD \cdot AC = AD \cdot BC + CD \cdot AB.$$

3. Find the distance between the points $(2, -3)$ and $(-3, 4).$

Ans. $\sqrt{74}.$

4. Find a point equidistant from the three points $(8, 6), (2, -2), (8, -2).$ Let its co-ordinates be (x, y) ; then we have

$$(x - 8)^2 + (y - 6)^2 = (x - 2)^2 + (y + 2)^2 = (x - 8)^2 + (y + 2)^2$$

$$\text{or } -4x + 4y + 8 = -16x + 4y + 68 = -16x - 12y + 100.$$

Solving these equations, we have $x = 5, y = 2.$

5. Express that the point (x, y) is equidistant from $(1, 2)$ and $(3, 4)$.

$$\text{Ans. } x + y - 5 = 0.$$

From Elementary Geometry we know that (x, y) must lie on a line which bisects perpendicularly the line joining the given points.

6. Find the distance between $(1, -3)$ and $(0, -2)$. Ans. $\sqrt{2}$.

7. Find the areas of these triangles :

(α) $(-4, -1), (3, -2), (2, 1)$. Ans. 10.

(β) $(4, -5), (-3, -6), (2, 3)$. Ans. 29.

(γ) $(4, 5), (16, 9), (-2, 3)$. Ans. 0.

i.e. the points are collinear.

8. Find the distance between the points of intersection of

$$x^2 + y^2 = 25, \quad 4x - 3y = 7. \quad \text{Ans. } 1\frac{2}{3}.$$

9. Show that the points $(0, 0)$, $(4, \frac{7\pi}{18})$, and $(4, \frac{\pi}{18})$ form an equilateral Δ .

10. Express in polar co-ordinates the equation $x^2 - y^2 = a^2$.

$$\text{Ans. } \rho^2 \cos 2\theta = a^2.$$

11. G is the centroid of ΔABC . Prove by co-ordinates that

$$\Delta GBC = \frac{1}{3} \Delta ABC.$$

12. Find the equations of lines through the origin and inclined respectively at 45° , 60° , and 120° to the x -axis.

$$\text{Ans. } y = x, \quad y = x\sqrt{3}, \quad y = -x\sqrt{3}.$$

13. Find the equation of a line through $(1, 2)$ and at 60° to x -axis.

$$\text{Ans. } x\sqrt{3} - y = \sqrt{3} - 2.$$

14. Find the line through $(0, -3)$ and at 45° to x -axis.

$$\text{Ans. } y = x - 3.$$

15. Find the line through $(1, 2)$ and parallel to the line $y = 2x + 3$.

$$\text{Ans. } y = 2x.$$

16. Find the line through $(3, 5)$ whose intercepts are equal.

$$\text{Ans. } x + y = 8.$$

17. Find the line through $(3, 3)$ which forms with the axes a triangle whose area is 18.

$$\text{Ans. } x + y = 6.$$

18. Show that the lines

$$\frac{x}{a} + \frac{y}{b} = 1, \quad \frac{x}{b} + \frac{y}{a} = 1, \quad x = y,$$

are concurrent in the point $(\frac{ab}{a+b}, \frac{ab}{a+b})$.

19. Find area of Δ whose sides are

$$x - y = 0, \quad x + 3y = 0, \quad x + y + 4 = 0. \quad \text{Ans. } 8.$$

Also the Δ whose sides are

$$3x + y - 7 = 0, \quad x + 7y + 11 = 0, \quad x - 3y + 1 = 0. \quad \text{Ans. } 10.$$

20. Find the equations of the medians of the Δ whose vertices are $(2, 1)$, $(3, -2)$, $(-4, -1)$.

$$\text{Ans. } x - y - 1 = 0, \quad x + 2y + 1 = 0, \quad x - 13y - 9 = 0.$$

21. Find the equation of the line joining the points (a, b) and (b, a) .

$$\text{Ans. } x + y = a + b.$$

Also the line joining the points (a, b) , $(-a, -b)$. $\text{Ans. } bx - ay = 0.$

22. Show that these points are collinear; $(1, -1)$, $(2, 1)$, $(-3, -9)$. Find the ratio of the segments into which these points divide the line.

$$\text{Ans. } \frac{1}{4}.$$

23. Find the equations of (1) The line joining the origin to the intersection of $y = 2x - 3$ and $x + 3y + 4 = 0$. (2) The line joining $(-4, 7)$ to the intersection of $y = 3x - 1$, $x = y - 1$.

$$\text{Ans. } (1) 11x + 5y = 0. \quad (2) x + y - 3 = 0.$$

24. Find the lines through the intersection of $y = 3x - 1$, $x = y - 1$ and parallel respectively to the x -axis and $4x + 5y + 6 = 0$.

$$\text{Ans. } y = 2, \quad 4x + 5y - 14 = 0.$$

25. Find the line joining the intersection of

$$2x + 3y + 3 = 0, \quad x + 2y + 2 = 0,$$

to that of $2x + y + 3 = 0, \quad 3x + 2y + 4 = 0.$

$$\text{Ans. } x + y + 1 = 0.$$

26. Through the vertices of the Δ whose sides are

$$x + 2y - 5 = 0, \quad 2x + y - 7 = 0, \quad y - x - 1 = 0,$$

parallels are drawn to the opposite sides. Find their equations.

$$\text{Ans. } x - y - 2 = 0, \quad x + 2y - 8 = 0, \quad 2x + y - 4 = 0.$$

27. Two lines can be drawn through $(6, -4)$ each of which forms with the axes a Δ whose area is $\frac{1}{6}$; find their equations.

$$\text{Ans. } 3x + 4y - 2 = 0, \quad 16x + 27y + 12 = 0.$$

28. Find the angles between these pairs of lines:—

$$(\alpha) \quad 5y - 3x + 1 = 0, \quad y - 4x + 2 = 0.$$

$$(\beta) \quad 2x - 3y = 0, \quad 6x + 4y + 7 = 0.$$

$$(\gamma) \quad y + x = 0, \quad (2 + \sqrt{3})y - x = 0.$$

$$(\delta) \quad y - kx = 0, \quad (1 - k)y - (1 + k)x = 0.$$

$$\text{Ans. } 45^\circ, 90^\circ, 60^\circ, 45^\circ.$$

29. Find the acute angle between the lines

$$2x + 3y - 4 = 0, \quad 4x - 5y - 6 = 0$$

$$\text{Ans. } \sin^{-1} \frac{22}{\sqrt{533}}$$

30. Find a line through
- $(0, -1)$
- and
- \perp
- to
- $x + y - 1 = 0$
- .

$$\text{Ans. } x - y - 1 = 0.$$

31. Find the lines through the origin and inclined at
- 45°
- to

$$y + x\sqrt{3} = 0. \quad \text{Ans. } y + x(2 - \sqrt{3}) = 0.$$

$$y - x(2 + \sqrt{3}) = 0.$$

32. Find the line through
- $(1, 2)$
- and
- \perp
- to
- $3x + 4y + 5 = 0$
- .

$$\text{Ans. } 4x - 3y + 2 = 0.$$

33. Find the line through
- $(2, 3)$
- and
- \perp
- to the line joining
- $(1, 2)$
- and
- $(-3, -14)$
- .

$$\text{Ans. } x + 4y - 14 = 0.$$

34. Find the distance from
- $(2, 3)$
- to the line
- $3x + 4y - 20 = 0$
- .

$$\text{Ans. } -\frac{2}{5}.$$

Also from the origin to $3x + 4y + 20 = 0$.

$$\text{Ans. } 4.$$

35. Find the distances from
- $(1, 3)$
- ,
- $(2, -3)$
- ,
- $(0, 0)$
- , on the line
- $4x - 5y + 6 = 0$
- .

$$\text{Ans. } \frac{5}{\sqrt{41}}, \frac{29}{\sqrt{41}}, \frac{6}{\sqrt{41}}.$$

36. Find the equations of the altitudes of the
- Δ
- $(-4, -6)$
- ,
- $(12, 2)$
- ,
- $(3, 8)$
- .

$$\text{Ans. } 2x + y = 14, \quad x + 2y = 16, \quad 3x - 2y = 0.$$

Find the ortho-center of this Δ .

$$\text{Ans. } (4, 6).$$

Also the lengths of these altitudes.

$$\text{Ans. } \frac{21}{\sqrt{5}}, \frac{24}{\sqrt{5}}, \frac{56}{\sqrt{13}}.$$

37. Find the equations of the
- \perp
- bisectors of the sides of the preceding
- Δ
- .

$$\text{Ans. } 2x + y - 6 = 0, \quad 2x + 4y - 3 = 0, \quad 6x - 4y - 25 = 0.$$

Find their point of concurrence.

$$\text{Ans. } (3\frac{1}{2}, -1).$$

38. Find the line joining the feet of the
- \perp
- s from origin on the lines
- $3x - 4y + 25 = 0$
- ,
- $12x + 5y - 169 = 0$
- .

$$\text{Ans. } x - 15y + 63 = 0.$$

Find also the distance between the feet of the \perp s.

$$\text{Ans. } \sqrt{226}.$$

39. Find the points on the line
- $3x - y - 1 = 0$
- at a distance 2 from the line
- $12x - 5y + 24 = 0$
- .

$$\text{Ans. } (1, 2), \left(\frac{55}{3}, 54\right).$$

40. Find the center of the inscribed
- \odot
- of the
- Δ
- ,
- (1)
- whose sides are

$$3x - 4y = 0, \quad 8x + 15y = 0, \quad x = 20.$$

- (2)
- whose vertices are
- $(2, 5)$
- ,
- $(1, 2)$
- ,
- $(3, 4)$
- .

$$\text{Ans. } (13, 1), (\sqrt{5}, 4).$$

41. If the angle between the axes is 60° , find the \perp from $(1, 1)$ on

$$2x + 3y + 4 = 0. \quad \text{Ans. } 4x - y - 3 = 0.$$

Find also its length.

$$\text{Ans. } \frac{2\sqrt{3}}{\sqrt{7}}.$$

42. ABC is a right- Δ , $\angle C$ being 90° . Squares ACED, BCGH, are described on AC, BC. Show that BD and AH meet on the \perp from C on AB.

43. OIN and OLM are given straight lines ; I and N are fixed points ; IL and NM meet at P. Find the locus of P if

$$\frac{\alpha}{OL} + \frac{\beta}{OM} = 1, \quad \text{where } \alpha \text{ and } \beta \text{ are constants.}$$

Ans. A straight line.

44. Determine k so that

$$x^2 + kxy - 8y^2 + 12y - 4 = 0.$$

may represent a line-pair.

$$\text{Ans. } k = \pm 2.$$

45. Find the line-pair which joins the origin to the intersection of

$$2x + y = 6, \text{ and } x^2 + y^2 = x + 5y + 6.$$

$$\text{Ans. } x^2 + y^2 = x + 5y \left(\frac{2x + y}{6} \right) + 6 \left(\frac{2x + 5y}{6} \right)^2,$$

or $xy = 0$, i.e. the axes.

Hence the given curves intersect on the axes.

46. Interpret the following equations :

$$(1) (x - 3)(y - 4) = 0.$$

$$(4) x^2 - y^2 = 0.$$

$$(2) x^2 - 3ax + 2a^2 = 0.$$

$$(5) xy - 2x + 3y - 6 = 0.$$

$$(3) xy = 0.$$

$$(6) 6xy + 2bx + 3ay + ab = 0.$$

47. Find the line joining the origin to the intersection of

$$\frac{x}{a} + \frac{y}{b} = 1 \quad \text{and} \quad \frac{x}{b} + \frac{y}{a} = 1. \quad \text{Ans. } x = y.$$

48. Find the diagonals of the \square whose sides are

$$3x - 2y = 1, \quad 4x - 5y = 6, \quad 3x - 2y = 2, \quad 4x - 5y = 3.$$

$$\text{Ans. } 13x - 11y - 9 = 0, \quad 5x - y = 0.$$

Find also the area of the \square .

$$\text{Ans. } \frac{3}{4}.$$

49. Show that the lines

$$Bx^2 - 2Hxy + Ay^2 = 0$$

are \perp to the lines

$$Ax^2 + 2Hxy + By^2 = 0.$$

50. Find the condition that one of the lines

$$Ax^2 + 2Hxy + By^2 = 0$$

may coincide with one of the lines

$$A_1x^2 + 2H_1xy + B_1y^2 = 0.$$

$$\text{Ans. } 4(AH_1 - A_1H)(HB_1 - H_1B) = (AB_1 - A_1B)^2.$$

51. Find also the condition that a line of the first pair may be \perp to a line of the second pair.

SUGGESTION.—In the preceding condition put B , $-H$, and A for A , H , and B (by Ex. 49).

52. Find the lines through (α, β) and \perp to the lines

$$Ax^3 + Bx^2y + Cxy^2 + Dy^3 = 0.$$

$$\text{Ans. } D(x-\alpha)^3 - C(x-\alpha)^2(y-\beta) + B(x-\alpha)(y-\beta)^2 - A(y-\beta)^3 = 0.$$

53. Find the conditions that two of the lines

$$Ax^4 + Bx^3y + Cx^2y^2 + Dxy^3 + Ey^4 = 0$$

should bisect the angles between the other two.

SUGGESTION.—Put (See § 47.)

$$Ax^4 + Bx^3y + \dots \equiv$$

$$(A_1x^2 + 2H_1xy + B_1y^2) \left(x^2 - \frac{A_1 - B_1}{H_1}xy - y^2 \right).$$

Multiply out and equate coefficients. Then eliminate A_1 , H_1 , and B_1 .

$$\text{Ans. } 3A + 3E + C = 0.$$

$$2(A - E)^2(A + E) = (B + D)(BE + DA).$$

54. Determine λ so that two of the lines (See § 46, note.)

$$2xy(Ax + By) - \lambda(x^3 + y^3) = 0 \quad \text{may be } \perp.$$

SUGGESTION :—

$$\text{Put } 2xy(\dots) - \lambda(\dots) \equiv$$

$$(x^2 - kxy - y^2)(mx + ny)$$

multiply out and equate coefficients. We get equations to determine m , n , k , and λ .

$$\text{Ans. } \lambda = 0, \text{ or } \lambda = A + B.$$

55. Find the condition that one of the lines

$$Ax^3 + 3Bx^2y + 3Cxy^2 + Dy^3 = 0$$

may bisect the \sphericalangle between the other two.

$$\text{Ans. } A(B+D)^3 - D(A+C)^3 = 3(A+C)(B+D)(B^2+BD-AC-C^2).$$

56. Any tangent to a circle, radius r , meets the tangents at the ends of a diameter AB in P and Q .

Prove

$$AP \cdot BQ = r^2.$$

57. Show that these circles are coaxial ;

$$x^2 + y^2 + 4x + y - 3 = 0.$$

$$x^2 + y^2 - x - y - 1 = 0.$$

$$x^2 + y^2 + 14x + 5y - 7 = 0.$$

58. Find the length of the common chord of the circles

$$x^2 + y^2 - 4x - 2y - 20 = 0.$$

$$x^2 + y^2 + 8x + 14y = 0.$$

Ans. 8.

SUGGESTION. — Find the radical axis. Then find length of chord of this axis intercepted by the first circle.

59. Find the locus of a point which moves so that the tangents from it to the circles

$$x^2 + y^2 - 3 = 0, \quad x^2 + y^2 - 3x - 6 = 0,$$

are in the ratio 2 : 3.

Ans. The circle $5(x^2 + y^2) + 12x - 3 = 0$.

60. Find the external common tangents to the circles

$$x^2 + y^2 - 4x - 2y + 4 = 0,$$

$$x^2 + y^2 + 4x + 2y - 4 = 0.$$

Ans. $y = 2, \quad 4x - 3y = 10$.

Find also the internal common tangents. *Ans.* $x = 1, \quad 3x + 4y = 5$.

61. Find the external common tangents to the circles

$$x^2 + y^2 - 6x - 8y = 0, \quad x^2 + y^2 - 4x - 6y = 3.$$

Ans. $x + 2 = 0, \quad y + 1 = 0$.

62. Show that the tangents from the origin to the circle

$$(x - a)^2 + (y - b)^2 = r^2$$

touch the circle

$$(x - ka)^2 + (y - kb)^2 = (kr)^2.$$

Also, if any line through the origin cut these circles in P, Q, P', Q'.

Prove,

$$OP : OP' :: OQ : OQ' :: 1 : k.$$

SUGGESTION. — Put $x = \rho \cos \theta, y = \rho \sin \theta$, in the first equation ; it becomes

$$\rho^2 - 2\rho(a \cos \theta + b \sin \theta) + a^2 + b^2 - r^2 = 0.$$

Solving this quadratic in ρ , its roots are OP and OQ. Similarly with the second circle, etc.

63. Find the circle through the origin and the intersections of

$$x^2 + y^2 + 3x + 4y + 2 = 0,$$

and

$$2x + 3y + 4 = 0.$$

Also, the circle through (1, 2) and the same intersections.

$$\text{Ans. } 2(x^2 + y^2) + 4x + 5y = 0,$$

$$2(x^2 + y^2) - y - 8 = 0.$$

64. Transform these equations to rectangular co-ordinates, pole at origin ;

$$(1) \rho = a \cos \theta,$$

$$(2) \rho = 2a \cos \theta + 2b \sin \theta$$

in (1) multiply by ρ ,

$$\therefore \rho^2 = a (\rho \cos \theta)$$

$$\therefore x^2 + y^2 = ax.$$

in (2)

$$\rho^2 = 2a (\rho \cos \theta) + 2b (\rho \sin \theta)$$

or,

$$x^2 + y^2 = 2ax + 2by,$$

$$\therefore (x-a)^2 + (y-b)^2 = a^2 + b^2.$$

65. Two circles intersect in O ; through O any line is drawn, cutting the circles in P and Q ; find locus of mid-point of PQ.

SOLUTION. — Take O for the origin and let the circles be

$$x^2 + y^2 + 2G_1x + 2F_1y = 0,$$

$$x^2 + y^2 + 2G_2x + 2F_2y = 0.$$

Or in polar co-ordinates,

$$\left. \begin{aligned} \rho + 2G_1 \cos \theta + 2F_1 \sin \theta &= 0, \\ \rho + 2G_2 \cos \theta + 2F_2 \sin \theta &= 0. \end{aligned} \right\} \begin{array}{l} \text{Now let OP make} \\ \angle \theta \text{ with } x\text{-axis.} \end{array}$$

$$\therefore OP = -2G_1 - 2F_1 \sin \theta,$$

and

$$OQ = -2G_2 \cos \theta - 2F_2 \sin \theta.$$

Let M be the mid-point of PQ and let $OM = \rho$. Then $2\rho = OP + OQ$.

Hence the required locus is,

$$2\rho = -2(G_1 + G_2) \cos \theta - (2F_1 + F_2) \sin \theta,$$

$$\text{or, } \rho^2 + (G_1 + G_2) (\rho \cos \theta) + (F_1 + F_2) (\rho \sin \theta) = 0,$$

$$\text{or, } x^2 + y^2 + (G_1 + G_2)x + (F_1 + F_2)y = 0,$$

i.e. another circle through O.

66. Two segments AB and CD of a given line subtend equal angles at P ; find the locus of P.

SUGGESTION. — Take the given line as x -axis and a point O on it as the origin. Let OA, OB, OC, OD be denoted by a, β, γ, δ , respectively. Then the required locus is the circle,

$$[a - \beta - \gamma + \delta] (x^2 + y^2) + 2(\beta\gamma - a\delta)x + \gamma\delta(a - \beta) - a\beta(\gamma - \delta) = 0.$$

67. Find the equation of a tangent to the circle $x^2 + y^2 = a^2$ at the point $(a \cos \alpha, a \sin \alpha)$.

SOLUTION. — Let $(a \cos \beta, a \sin \beta)$ be another point on the circle. Then the chord joining the two points is,

$$\begin{vmatrix} x & y & 1 \\ a \cos \alpha & a \sin \alpha & 1 \\ a \cos \beta & a \sin \beta & 1 \end{vmatrix} = 0.$$

or, $x \cos \frac{1}{2}(\alpha + \beta) + y \sin \frac{1}{2}(\alpha + \beta) = a \cos \frac{1}{2}(\alpha - \beta).$

Now put $\alpha = \beta$ and the chord becomes a tangent at the point $(a \cos \alpha, a \sin \alpha)$ viz. : $x \cos \alpha + y \sin \alpha = a.$

68. Find the locus of the mid-point of chords of the circle $x^2 + y^2 = a^2$, drawn through the fixed point (h, k) . Take $(a \cos \alpha, a \sin \alpha)$ and $(a \cos \beta, a \sin \beta)$ as the extremities of one of these chords. Let (x, y) be the mid-point of the chord.

Then we have $2x = a(\cos \alpha + \cos \beta)$

$$2y = a(\sin \alpha + \sin \beta)$$

$$h \cos \frac{1}{2}(\alpha + \beta) + k \sin \frac{1}{2}(\alpha + \beta) = a \cos \frac{1}{2}(\alpha - \beta).$$

Eliminating α, β , from these three equations, we get for the required locus $x^2 + y^2 = hx + ky.$

69. Given the base of a $\triangle ABC$, and $ab \sin(C - \alpha) = k^2$, where α is a given angle. Find locus of the vertex. Take side AB as x -axis, A the origin.

Ans. The circle, $x^2 + y^2 - cx - cy \cot \alpha + k^2 \csc \alpha = 0$ [where a, b, c are the lengths of the sides].

70. A and B are fixed points; M, N, are variable points on AB such that $\overline{AM}^2 + \overline{MN}^2 + \overline{BN}^2 = k^2.$

If PMN is an equilateral \triangle , find the locus of P.

SUGGESTION. — Take A as origin, AB as x -axis, let AB = $a.$

Ans. The circle $2(x^2 + y^2) - 2ax - \frac{2ay}{\sqrt{3}} = k^2 - a^2.$

71. Find the equation of the chord joining the two points $(2a \cos \alpha, \alpha)$ and $(2a \cos \beta, \beta)$ on the circle

$$\rho = 2a \cos \theta.$$

Ans. $2a \cos \beta \cos \alpha = \rho \cos(\beta + \alpha - \theta).$

NOTE. — The tangent to the circle, at the first point, is found by putting $\beta = \alpha$ in this result.

Ans. $2a \cos^2 \alpha = \rho \cos(2\alpha - \theta).$

72. Show that the polar of a point with regard to any circle of a coaxial system passes through a fixed point.

SUGGESTION. — The polar of (h, k) with respect to the circle

$$x^2 + y^2 + 2\lambda x = c^2$$

is $hx + ky + \lambda(x + h) = c^2.$

The fixed point is determined by the equations

$$x + h = 0, hx + ky = c^2.$$

73. Find the circles through (1, 2), (1, 18) and touching the x -axis.

Ans. $x^2 + y^2 + 10x - 20y + 25 = 0,$
 $x^2 + y^2 - 14x - 20y + 49 = 0.$

74. Find the circle through (2, 0) which cuts the circles

$$x^2 + y^2 = 4, \quad x^2 + y^2 = 2y + 8$$

at right angles.

Ans. $x^2 + y^2 - 4x + 4y + 4 = 0.$

75. A, B, C, D, are four concyclic points and O is any other point.

Prove $\overline{OA}^2 \cdot \text{area BCD} + \overline{OC}^2 \cdot \text{area ABD} =$
 $\overline{OB}^2 \cdot \text{area ACD} + \overline{OD}^2 \cdot \text{area ABC}.$

76. The line $Ax + By + C = 0,$ cuts the circle

$$x^2 + y^2 + 2G_1x + 2F_1y + C_1 = 0$$

in two points. Also the axis of x cuts the circle

$$x^2 + y^2 + 2G_2x + 2F_2y + C_2 = 0$$

in two points. Find the condition that these four points be concyclic.

SUGGESTION. — The lines $y = 0, Ax + By + C = 0,$ must meet on the radical axis.

Ans. $2C(G_1 - G_2) = A(C_1 - C_2).$

77. Find the co-ordinates of the limiting points of the circles

$$x^2 + y^2 + 2G_1x + 2F_1y + C_1 = 0,$$

$$x^2 + y^2 + 2G_2x + 2F_2y + C_2 = 0.$$

Ans. $x = -\frac{G_1 + \lambda G_2}{1 + \lambda}, \quad y = -\frac{F_1 + \lambda F_2}{1 + \lambda}$

where λ is either root of the equation

$$(G_1 + G_2\lambda)^2 + (F_1 + F_2\lambda)^2 = (1 + \lambda)(C_1 + C_2\lambda).$$

78. Two chords of a circle cut at right angles show that the tangents at their extremities form a quadrilateral whose vertices are **concylic**. Hence prove that the problem: *To inscribe a quadrilateral in a circle whose sides shall touch another given circle* is either **indeterminate** or **impossible**.

79. A and B are points on the circle $x^2 + y^2 = a^2,$ and AB subtends a right angle at the fixed point $(h, k).$ Find the locus of the mid-point of AB.

SOLUTION. — Let A be $(a \cos \alpha, a \sin \alpha)$ and B $(a \cos \beta, a \sin \beta).$

Then, the co-ordinates of the mid-point of AB are

$$x = \frac{1}{2} (a \cos \alpha + a \cos \beta) \dots \dots \dots (1)$$

$$y = \frac{1}{2} (a \sin \alpha + a \sin \beta) \dots \dots \dots (2)$$

Also the equation of a circle described on AB as a diameter is

$$(x - a \cos \alpha) (x - a \cos \beta) + (y - a \sin \alpha) (y - a \sin \beta) = 0,$$

and since this passes through the fixed point (h, k) , we have

$$(h - a \cos \alpha) (h - a \cos \beta) + (k - a \sin \alpha) (k - a \sin \beta) = 0. \quad (3)$$

Hence we get the locus of the mid-point of AB by eliminating α and β from equations (1), (2), and (3). The result is

$$(x - h)^2 + (y - k)^2 + x^2 + y^2 = a^2.$$

Show also that the locus of the foot of a \perp from center of $x^2 + y^2 = a^2$ on AB is the **same** circle.

Also, find the locus of the intersection of tangents at A and B.

Ans. The circle $[h^2 + k^2 - a^2] (x^2 + y^2) - 2a^2hx - 2a^2ky + 2a^4 = 0$.

80. Find the equation of the circle intersecting the circle

$$x^2 + y^2 + 3x + 5y + 2 = 0,$$

in the chord

$$x + 2y - 3 = 0,$$

and the circle

$$x^2 + y^2 - x + y - 2 = 0$$

in the chord

$$2x + y + 6 = 0.$$

$$\text{Ans. } 3(x^2 + y^2) + 5x + 7y + 18 = 0.$$

Determine under what conditions such a problem is possible.

Ans. The two lines must meet on the **radical axis** of the circles.

NOTE. — This may be easily shown by Elementary Plane Geometry.

81. Find the locus of a point such that the two pairs of tangents drawn therefrom to the circles

$$x^2 + y^2 + 2Gx = 0,$$

and

$$x^2 + y^2 + 2Fy = 0,$$

may form a **harmonic pencil**.

Ans. The two parallel lines $Gx - Fy = \pm FG$.

82. The equations of two circles taking a **center of similitude** as origin may be written

$$x^2 + y^2 - 2ax + a^2 \cos^2 \psi = 0,$$

$$x^2 + y^2 - 2\beta x + \beta^2 \cos^2 \psi = 0.$$

Find the equation of the circle passing through the four points of contact of the common tangents from the origin.

$$\text{Ans. } x^2 + y^2 - (\alpha + \beta)x + \alpha\beta \cos^2 \psi = 0.$$

83. Is the point $(1, 2)$ inside or outside the parabola $y^2 = 8x$?

84. Find the points of intersection of

$$y = 2x - 4a,$$

and

$$y^2 = 4ax.$$

$$\text{Ans. } (a, -2a), (4a, 4a).$$

85. Show that, $y = x + 3$ touches the parabola $y^2 - 8x - 8 = 0$.

Ans. Point of contact is (1, 4).

86. Find the length of the chord made by the line $2x + y = 8$ on the parabola $y^2 = 8x$.

Ans. $6\sqrt{5}$.

87. Find the co-ordinates of the focus, equation of directrix, and the length of latus rectum in the following parabolas :

(1) $y^2 = -4ax$. *Ans.* $(-a, 0)$, $x = a$, $4a$.

(2) $x^2 = -4ay$. *Ans.* $(0, -a)$, $y = a$, $4a$.

(3) $(y - 1)^2 = 4(x - 2)$. *Ans.* (3, 1), $x = 1$, 4.

(4) $x^2 + 4y + 8 = 0$. *Ans.* $(0, -3)$, $y + 1 = 0$, 4.

88. Find locus of intersection of tangents to parabola $y^2 = 4ax$ inclined at 60° .

Ans. $3x^2 - y^2 + 10ax + 3a^2 = 0$.

89. Find the chord joining the points of contact of the tangents,

$$y = m_1x + \frac{a}{m_1},$$

$$y = m_2x + \frac{a}{m_2}.$$

Ans. $2(m_1m_2x + a) = y(m_1 + m_2)$.

SUGGESTION. — The points are $\left(\frac{a}{m_1^2}, \frac{2a}{m_1}\right)$ and $\left(\frac{a}{m_2^2}, \frac{2a}{m_2}\right)$.

90. The line joining the point P on a parabola to the vertex cuts the \perp from focus on tangent at P in Q. Find locus of Q.

Ans. $y^2 + 2x^2 - 2ax = 0$.

91. The equation of the tangents to the parabola from (h, k) may be written in either of the forms,

$$h(y - k)^2 - k(y - k)(x - h) + a(x - h)^2 = 0,$$

or, $(k^2 - 4ah)(y^2 - 4ax) = [ky - 2a(x + h)]^2$.

SUGGESTION. — See note on Joachimsthal's method in Appendix.

92. If the intercept of the tangents from P on tangent at vertex is constant, find locus of P.

Ans. An equal parabola.

SUGGESTION. — If P is (h, k) intercept is $\sqrt{k^2 - 4ah}$.

93. (x_1, y_1) , (x_2, y_2) , (x_3, y_3) , and (x_4, y_4) are the vertices of a re-entrant or concave quadrilateral whose sides touch the parabola.

Prove

$$x_1x_2 = x_2x_4 \text{ and } y_1 + y_3 = y_2 + y_4.$$

94. Normals to a parabola are drawn at two points on opposite sides of the axes whose abscissæ are in the ratio 1 : 4. Find the locus of their intersection.

Ans. The curve $27ay^2 = 4(x - 2a)^3$.

95. Find the co-ordinates of the second point in which the normal at the point $\left(\frac{a}{m^2}, \frac{2a}{m}\right)$ meets the parabola.

$$\text{Ans. } x = \frac{a(2m^2 + 1)^2}{m^2}, \quad y = -\frac{2a(2m^2 + 1)}{m}$$

SUGGESTION. — The normal is

$$m^3y + m^2(x - 2a) - a = 0.$$

Eliminate x from this and $y^2 = ax$.

$$\therefore m^2y^2 + 4am^3y - 4a^2(2m^2 + 1) = 0.$$

The product of the roots of this quadratic in y is, $\frac{-4a^2(2m^2 + 1)}{m^2}$.

But one root is $\frac{2a}{m}$; find the other by division; etc.

96. Find the equations of the common tangents to the parabola $y^2 = 4ax$ and the circle $2(x^2 + y^2) - 9ax = 0$.

$$\text{Ans. } 12y \pm 16x \pm 9a = 0.$$

97. PQ is a normal chord of a parabola, F is the focus. Find the locus of the center of gravity of $\triangle FPQ$.

$$\text{Ans. The curve } 36ay^2(3x - 5a) - 81y^4 - 128a^4 = 0.$$

98. A circle cuts the parabola $y^2 = 4ax$ in four points whose ordinates are y_1, y_2, y_3, y_4 .

Prove $y_1 + y_2 + y_3 + y_4 = 0$.

SUGGESTION. — Eliminate x from $y^2 = 4ax$

and $(x - h)^2 + (y - k)^2 = r^2$.

It gives a **biquadratic in y** which lacks the term in y^3 , etc.

99. Find the locus of poles of chords of the parabola whose mid-points lie on the fixed line

$$Ax + By + C = 0.$$

$$\text{Ans. The parabola } A(y^2 - 2ax) + 2a(By + C) = 0.$$

100. $(\alpha_1, \beta_1), (\alpha_2, \beta_2), (\alpha_3, \beta_3)$ are the feet of the normals from (h, k) to the parabola. Find a relation between them.

$$\text{Ans. } \beta_2\beta_3(\alpha_2 - \alpha_3) + \beta_3\beta_1(\alpha_3 - \alpha_1) + \beta_1\beta_2(\alpha_1 - \alpha_2) = 0.$$

101. TP, TQ, are tangents to a parabola; TL is a \perp to the axis and the \perp from T on PQ meets the axis in M. Prove $2LM = \text{latus rectum}$.

102. The major axis of an ellipse is divided into two parts equal to the focal distances of a point P on the ellipse. Prove that the distance of the point of division from either end of the minor axis is equal to the distance of P from the minor axis.

103. Find the co-ordinates of the mid-point of the chord which the ellipse $\frac{x^2}{a^2} + \frac{y^2}{b^2} = 1$ intercepts on the line $Ax + By + C = 0$.

$$\text{Ans. } -\frac{A \cdot C \cdot a^2}{a^2A^2 + b^2B^2}, \quad -\frac{B \cdot C \cdot b^2}{a^2A^2 + b^2B^2}.$$

104. Determine C so that

$$y = x + C$$

may touch the ellipse $2x^2 + 3y^2 = 1$. Ans. $C = \pm \frac{1}{6} \sqrt{13}$.

105. Find the tangents to the ellipse

$$3x^2 + 4y^2 = 12$$

which cut off equal intercepts on the axes. Ans. $y \pm x = \pm \sqrt{7}$.

106. OP, OQ are semi-diameters of an ellipse at right angles.

Prove that PQ touches a fixed circle whose center is O.

SOLUTION.—Let the \perp from O on PQ = p . Let α be the \angle which it makes with OP. Then

$$\frac{\cos \alpha}{p} = \frac{1}{OP}, \quad \frac{\sin \alpha}{p} = \frac{1}{OQ};$$

square and add

$$\therefore \frac{1}{p^2} = \frac{1}{OP^2} + \frac{1}{OQ^2} = \frac{1}{a^2} + \frac{1}{b^2}$$

hence p is constant, \therefore etc.

107. P is any point on the ellipse; the \perp bisectors of AP and A'P meet AA' in M and M'. (A, A' are the vertices).

Prove $MM' = \frac{1}{a}(a^2 - b^2)$.

NOTE.—This furnishes a method of describing the ellipse mechanically.

108. PN and PM are the \perp s from a point P on two given oblique axes, $\angle \phi$.

If $\overline{PN}^2 + \overline{PM}^2 = k^2$, find locus of P.

Ans. Ellipse $(x^2 + y^2) \sin^2 \phi = k^2$, referred to its equi-conjugate diameters.

The semi-axes a and b are determined by the equations,

$$\frac{k^2}{\sin^2 \phi} = \frac{a^2 + b^2}{2}, \quad \frac{b}{a} = \text{ctn} \cdot \frac{\phi}{2}$$

$$\therefore e^2 = 1 - \text{ctn}^2 \frac{\phi}{2}.$$

109. Find the equation of a conic, having axes coincident with the co-ordinate axes and passing through the points $(2\sqrt{2}, \sqrt{3})$ and $(4, 3)$. Find also its eccentricity. *Ans.* $3x^2 - 4y^2 = 12$; $\frac{1}{2}\sqrt{7}$.

110. A straight line PQ subtends a right angle at each of two fixed points A and B. If P describes a straight line, show that Q describes a hyperbola whose asymptotes are \perp to AB and the given line, respectively.

111. P and Q are two points on an asymptote of a hyperbola, such that $OP = 2PQ$ [where O is center], and T is the point of contact of a tangent from P. The \sphericalangle PTP'Q being completed, show that its diagonals intersect on the curve.

112. Two ellipses have the same focus and eccentricity and their major axes coincide in direction. PN and P'N' are the ordinates of the larger ellipse which are tangent to the smaller. Prove

$$FP - FN = FP' - FN' \text{ (F is common focus).}$$

113. The ellipse $\frac{x^2}{a^2} + \frac{y^2}{b^2} = 1$ slides between two rectangular axes. Find the locus of its foci.

SUGGESTION. — Let $y = mx + \sqrt{m^2a^2 + b^2}$ be one of the axes; then put $-\frac{1}{m}$ for m to get the other. Now find the distances from a focus to these axes [tangents]. Call these distances x and y respectively and eliminate m , etc.

$$\text{Ans. } y^2(x^2 - b^2)^2 + x^2(y^2 - b^2)^2 + 2xy(x^2 - b^2)(y^2 - b^2) = 4x^2y^2(a^2 - b^2).$$

114. Find the equation of the normal to the conic $xy = k^2$ at the point $\left(k\lambda, \frac{k}{\lambda}\right)$, where ϕ is the angle between the axes of co-ordinates.

$$\text{Ans. } (\lambda^3 - \lambda \cos \phi)x + (\lambda^3 \cos \phi - \lambda)y = k(\lambda^4 - 1).$$

115. If the normals at A, B, C, of the above conic meet on the curve, find the locus of the center of gravity of the $\triangle ABC$.

$$\text{Ans. The conic } 9xy = k^2 \cos^2 \phi.$$



PART II

SOLID GEOMETRY



CHAPTER I

THE POINT

1. Fundamental ideas.*—A clear conception of the following principles will facilitate an understanding of the Geometry of Three Dimensions.

(1) In space, a straight line is regarded as the intersection of two planes. We may prove this statement thus: Since three points not in the same straight line determine a [one] plane, the intersection between two planes cannot contain three points not in the same straight line. Hence the intersection is a straight line.

(2) A point is the intersection of two straight lines, *i.e.*, the intersection of a straight line with a plane which cuts the plane of the line, *i.e.*, the intersection of three planes. Hence, a point in space will be determined by some relation to three given planes, a line by its relation to two planes, etc.

(3) A plane curve, lying in space, is regarded as the intersection between some surface or some solid with a plane. Thus, a circle might be determined [in space] by the intersection of a plane with a sphere, or with a right circular cylinder, cutting the latter at right angles to its axis.

2. Co-ordinates (rectangular).—The position of a point in space is determined by the intersection of three given planes. To assign convenient directions to these planes, three co-

* The student will do well at this juncture to refresh his memory on the propositions concerning planes and straight lines in Solid Geometry.

ordinate planes are assumed, all perpendicular to each other [consider three faces of a cube forming one corner], and meeting in a point called the **origin**. The point is referred to these, and three planes are passed through it parallel, respectively, to the co-ordinate planes. The distances of these new planes from the origin are the co-ordinates of the point.

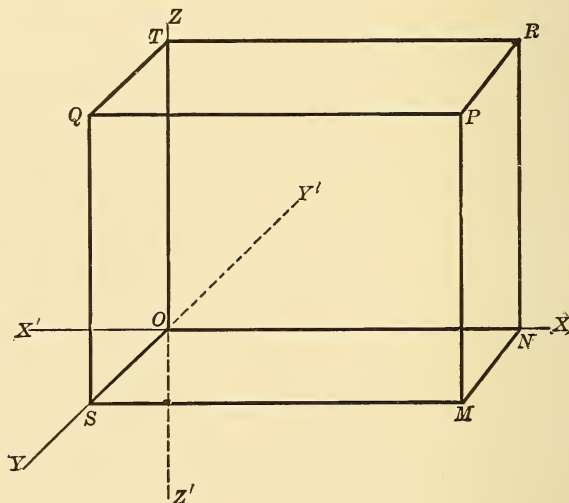

Fig. 151.

Thus, let XOY , YOZ , and ZOX , be three planes cutting each other at right angles in the origin O . These planes are called the xy , the yz , and the xz planes, respectively. Their lines of intersection, XX' , YY' , ZZ' , are called the x , y , and z -axes, respectively. Let P be any point in space through which three planes have been passed parallel to XOY , YOZ , and XOZ , respectively. Then, by definition, its co-ordinates are evidently PQ , PR , PM ; or, more simply, ON , NM , and PM , the distances measured parallel to the x , y , and z -axes, re-

spectively. The point P is now designated as the point (x, y, z) .

Again, the co-ordinate planes divide all space into eight compartments called **octants**, which are numbered as follows: (1) O — XYZ, (2) O — YX'Z, (3) O — X'Y'Z, (4) O — Y'XZ. The last four go in the same direction around, below the xy plane. Let the student name them. The convention of signs follows the same rule as in Plane Geometry; *i. e.*, opposite signs for opposite directions. Thus, distances [co-ordinates] measured in the direction of OX, OY, and OZ are positive, while those in the direction of OX', OY', OZ' are negative. If (x, y, z) are the lengths of the co-ordinates of any point, they have the following signs in the various octants:

	I	II	III	IV	V	VI	VII	VIII
x	+	-	-	+	+	-	-	+
y	+	+	-	-	+	+	-	-
z	+	+	+	+	-	-	-	-

These should be verified by the student.

3. To locate a point P. — In Fig. 151, § 2, measure

$$ON = x \text{ [on } x\text{-axis].}$$

$$NM = y \text{ [parallel to } y\text{-axis].}$$

$$MP = z \text{ [parallel to } z\text{-axis].}$$

The lengths ON, OS, OT may also be taken as the co-ordinates of P.

EXERCISE. — In which planes do the following points lie: (1) (x, y, o) , (2) (o, o, o) , (3) (x, o, o) , (4) (o, y, z) , (5) (x, o, z) , (6) (o, o, z) , (7) (o, y, o) , etc.?

4. **Polar co-ordinates.** — The point P may also be determined in space as follows :

Draw OP, and through it pass a plane \perp to the xy plane and cutting the latter in the line OM. The position of P is then known if the line OP, the radius vector, and the angles ϕ and θ , the vectorial angles, are given. These three magnitudes together constitute the polar co-ordinates of the point P.

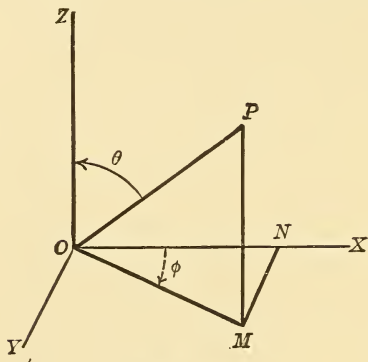

Fig. 152.

For transformation from rectangular to polar co-ordinates and *vice versa*, we have,

$$x = ON = OM \cos \phi = OP \sin \theta \cos \phi = \rho \sin \theta \cos \phi.$$

Similarly, we get y and z .

$$\left. \begin{aligned} x &= \rho \sin \theta \cos \phi, \\ y &= \rho \sin \theta \sin \phi, \\ z &= \rho \cos \theta. \end{aligned} \right\}$$

Also,

$$\left. \begin{aligned} \rho &= \sqrt{x^2 + y^2 + z^2}, \\ \tan \phi &= \frac{y}{x}, \\ \tan \theta &= \frac{\sqrt{x^2 + y^2}}{z}. \end{aligned} \right\}$$

5. **Direction angles. Relation among them.** — The angles which the radius vector of a point P makes with the axes are called its direction angles; and their cosines, the **direction cosines**. They are generally denoted by the Greek letters, α, β, γ .

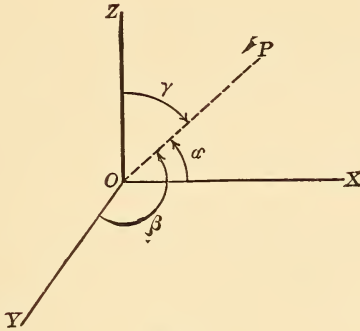

Fig. 153.

By projecting OP on the three axes, we get,

$$\left. \begin{aligned} x &= \rho \cos \alpha, \\ y &= \rho \cos \beta, \\ z &= \rho \cos \gamma. \end{aligned} \right\}$$

$$\therefore x^2 + y^2 + z^2 = \rho^2 (\cos^2 \alpha + \cos^2 \beta + \cos^2 \gamma).$$

$$\therefore \cos^2 \alpha + \cos^2 \beta + \cos^2 \gamma = 1.$$

NOTE. — The co-ordinates of a point are its projections on the axes.

Again, the direction cosines of the radius vector of any point (x, y, z) are obviously,

$$\left. \begin{aligned} \cos \alpha &= \frac{x}{\rho} = \frac{x}{\sqrt{x^2 + y^2 + z^2}} \\ \cos \beta &= \frac{y}{\rho} = \dots \dots \dots \\ \cos \gamma &= \frac{z}{\rho} = \dots \dots \dots \end{aligned} \right\}$$

Hence, (1) If any three real numbers are divided by the square root of the sum of their squares, the results are the direction cosines of some line, or of the radius vector of some point.

(2) The direction cosines of the radius vector of any point are proportional to the rectangular co-ordinates of the point.

EXAMPLE 1. — Find the direction cosines of the radius vector of the point (1, 2, 3).

$$\text{Ans. } \frac{1}{\sqrt{14}}, \frac{2}{\sqrt{14}}, \frac{3}{\sqrt{14}}.$$

EX. 2. — The point (1, 0, 3).

$$\text{Ans. } \frac{1}{\sqrt{10}}, 0, \frac{3}{\sqrt{10}}.$$

Hence, its radius vector is perpendicular to the y -axis, a fact which is also seen by observing that the point lies in the xz plane.

EX. 3. The direction cosines of a point are proportional to 3, 4, and 5. What are they?

$$\text{Ans. } \frac{3}{\sqrt{50}}, \frac{4}{\sqrt{50}}, \frac{5}{\sqrt{50}}.$$

Observe that these results may be simplified.

NOTE. — The projection of a given line on another line is equal to the product of the former by the cosine of their included angle.

6. The projection of the join of the ends of a broken line on a given line is equal to the sum of the projections

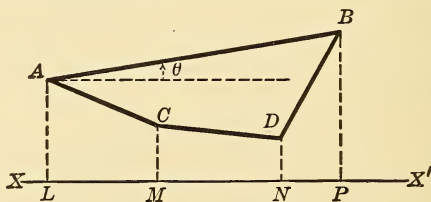

Fig. 154.

of the parts of that line. — Let the broken line be ACDB, and XX' the line on which it is to be projected.

Let $\theta_1, \theta_2, \theta_3$ be the angles made by AC, CD, DB with XX' .

Then $LP = LM + MN + NP,$

or, $AB \cos \theta = AC \cos \theta_1 + CD \cos \theta_2 + DB \cos \theta_3.$

\therefore , etc.

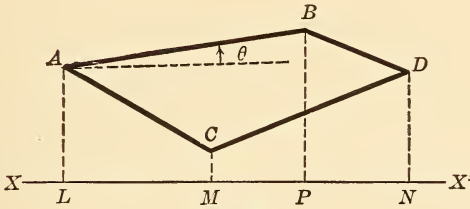

Fig. 155.

NOTE. — If any portion of the broken line has a negative direction, its angle is also negative, and therefore the product of its length by the cosine is always positive. This important principle of projections depends on the convention of signs, or the fact that the algebraic length of a line and the cosine of its angle always have the same sign.

7. Angle between two lines in terms of their direction cosines. — Let OP_1, OP_2 , be two radii vectores parallel respectively to two given lines in space, whose direction angles are respectively $(\alpha_1, \beta_1, \gamma_1), (\alpha_2, \beta_2, \gamma_2)$.

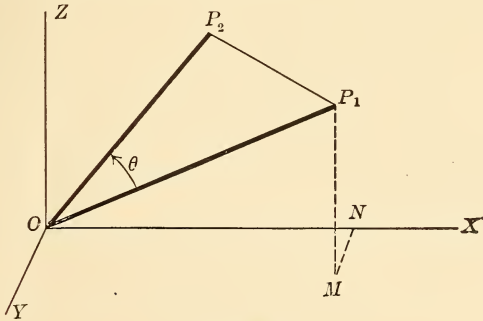

Fig. 156.

Then, the projection of OP_1 on $OP_2 =$ projection of the broken line $ONMP_1$ on OP_2 .

$$\begin{aligned} \therefore \rho_1 \cos \theta &= ON \cos \alpha_2 + MN \cos \beta_2 + MP_1 \cos \gamma_2 \\ &= (\rho_1 \cos \alpha_1) \cos \alpha_2 + (\rho_1 \cos \beta_1) \cos \beta_2 \\ &\quad + (\rho_1 \cos \gamma_1) \cos \gamma_2 \end{aligned}$$

[since the co-ordinates of P_1 are the projections of ρ_1 on the axes].

$$\therefore \cos \theta = \cos \alpha_1 \cos \alpha_2 + \cos \beta_1 \cos \beta_2 + \cos \gamma_1 \cos \gamma_2,$$

Which gives the cosine of the angle between the two lines in terms of their direction cosines.

DISCUSSION. — (1) If the given lines are parallel,

$$\alpha_1 = \alpha_2, \beta_1 = \beta_2, \gamma_1 = \gamma_2.$$

(2) If the lines are \perp , we have

$$\cos \alpha_1 \cos \alpha_2 + \cos \beta_1 \cos \beta_2 + \cos \gamma_1 \cos \gamma_2 = 0.$$

EXERCISES.

1. $(x_1, y_1, z_1), (x_2, y_2, z_2)$, are two points in space, d the distance between them, and α, β, γ the direction angles of the line joining them.

Prove,
$$d = \sqrt{(x_2 - x_1)^2 + (y_2 - y_1)^2 + (z_2 - z_1)^2}.$$

Also,
$$d \cos \alpha = x_2 - x_1, \text{ etc.}$$

$$\therefore \cos \alpha = \frac{x_2 - x_1}{d},$$

$$\cos \beta = \frac{y_2 - y_1}{d},$$

$$\cos \gamma = \frac{z_2 - z_1}{d}.$$

2. The square of any line is equal to the sum of the squares of its projections on the axes.

3. If (x, y, z) divides the distance between the points in Ex. 1 in the ratio of $m : n$, prove,

$$x = \frac{nx_1 + mx_2}{n + m},$$

$$y = \frac{ny_1 + my_2}{n + m},$$

$$z = \frac{nz_1 + mz_2}{n + m}.$$

4. If (x, y, z) is the mid-point, prove,

$$x = \frac{1}{2} (x_2 + x_1),$$

$$y = \frac{1}{2} (y_2 + y_1),$$

$$z = \frac{1}{2} (z_2 + z_1).$$

5. Find the distance between the points (2, 3, 6), (1, 2, 4). Between (1, 3, 5), (1, 2, 3).

6. Show that the triangle whose vertices are (1, 2, 3), (2, 3, 1), (3, 1, 2), is equilateral.

7. The projections of a line on the axes are 2, 5, 6. What is the length of the line? See Ex. 2.

8. If the origin is moved to the point (h, k, l), the axes remaining parallel to the old ones show that the formulas for transformation are

$$x = x' + h, \quad y = y' + k, \quad z = z' + l.$$

9. If the origin remains unchanged, and the axes are turned so that they make these direction angles with the old axes ($\alpha_1, \beta_1, \gamma_1$), ($\alpha_2, \beta_2, \gamma_2$), ($\alpha_3, \beta_3, \gamma_3$), prove that the formulas for transformation are as follows:

$$x = x' \cos \alpha_1 + y' \cos \alpha_2 + z' \cos \alpha_3.$$

$$y = x' \cos \beta_1 + y' \cos \beta_2 + z' \cos \beta_3.$$

$$z = x' \cos \gamma_1 + y' \cos \gamma_2 + z' \cos \gamma_3.$$

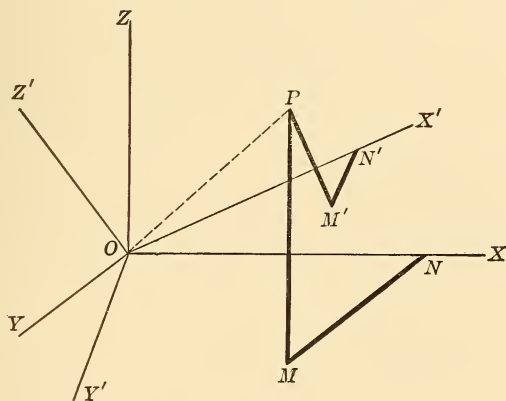

Fig. 157.

$$x = ON, \quad y = MN, \quad z = PM.$$

$$x' = ON', \quad y' = M'N', \quad z' = PM'.$$

Now, the projections of OP and ON'M'P on the x -axis [old] are equal. Similarly on the other axes. Hence, the above formulæ.

10. Find the radius vector with its direction cosines for each of the points (2, 4, 6), (3, -2, -1), (1, -2, -3).

11. The direction cosines of a line are proportional to 2, 5, and 7. What are they?

12. Two direction angles of a line are $[60^\circ \text{ and } 45^\circ]$; $[60^\circ \text{ and } 30^\circ]$; $[135^\circ \text{ and } 60^\circ]$. Find the third angle in each case.

Ans. (1) $[60^\circ \text{ or } 120^\circ]$; (2) $[90^\circ]$; (3) $[60^\circ \text{ or } 120^\circ]$.

13. Find the angle between the lines whose direction cosines are proportional to (2, 3, 5) and (-3, 2, -1).

14. Find the rectangular co-ordinates of the points

$$(1) \left(2, \frac{\pi}{4}, \frac{\pi}{2}\right), \quad (2) \left(4, \frac{\pi}{6}, \frac{\pi}{3}\right).$$

[Ans. (2) $1, \sqrt{3}, 2\sqrt{3}$].

15. Show that the distance between two points in terms of their polar co-ordinates is equal to

$$d = \sqrt{\rho_1^2 + \rho_2^2 - 2\rho_1\rho_2 [\cos(\theta_1 - \theta_2) \sin\phi_1 \sin\phi_2 + \cos\phi_1 \cos\phi_2]}.$$

16. Find the co-ordinates of the point which divides in the ratio of 1 : 3 the distance between (1, -2, 3), (2, 3, 5).

17. Find the co-ordinates of the point which divides in the ratio of 2 : 5, the distance between the points (1, 4, 6), (-2, -3, -6).

18. A line makes equal angles with the co-ordinate axes. Show,

$$\cos \alpha = \cos \beta = \cos \gamma = \frac{1}{\sqrt{3}}.$$

19. Find the polar co-ordinates of the point (2, 3, 6).

20. Prove by co-ordinates that the lines joining the mid-points of the opposite sides of any quadrilateral pass through a common point and are bisected by that point.

CHAPTER II

THE PLANE

8. Normal equation of the plane.—Let ON be the \perp from the origin to the plane. Let P be any point in the plane and OP its radius vector. Also, $ON = p$. The direction angles

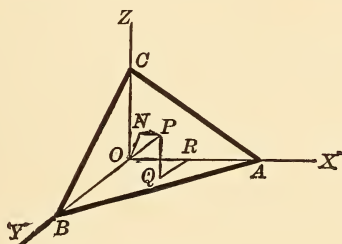

Fig. 158.

of OP are α, β, γ , and its co-ordinates $[OR, RQ, QP]$, x, y , and z . Then, the projection of OP on $ON =$ projection of $ORQP$ on ON . But ON is the projection of OP on ON since ON is \perp to plane.

$$\therefore x \cos \alpha + y \cos \beta + z \cos \gamma = p$$

is the required equation of the plane.

DISCUSSION.—(1) If the given plane is perpendicular to one of the co-ordinate planes, *e.g.*, the yz plane, then ON lies in the yz plane, and $\alpha = 90^\circ$, $\cos \alpha = 0$, and the equation becomes, $y \cos \beta + z \cos \gamma = p$.

(2) If parallel to one of the co-ordinate planes, xy , for example, ON lies in the z -axis, hence

$$\cos \alpha = 0, \cos \beta = 0, \cos \gamma = 1.$$

$$\therefore z = p. \quad [\text{Equation of the plane.}]$$

EXERCISES.

Interpret the following equations :

- | | |
|--------------------|--|
| 1. $3x + 4y = 6.$ | <i>Ans.</i> A plane \perp to xy plane. |
| 2. $5x + 2z = 9.$ | <i>Ans.</i> A plane \perp to xz plane. |
| 3. $2y - 5z = 10.$ | <i>Ans.</i> A plane \perp to yz plane. |
| 4. $x + y = 0.$ | 12. $z = 0.$ |
| 5. $2x - 3z = 0.$ | 13. $xyz = 0.$ |
| 6. $4y + 2z = 16.$ | 14. $xy = 0.$ |
| 7. $x = \pm 3.$ | 15. $xz = 0.$ |
| 8. $x = 0.$ | 16. $yz = 0.$ |
| 9. $y = \pm 6.$ | 17. $2y - z = 0.$ |
| 10. $y = 0.$ | 18. $x + z = 3.$ |
| 11. $z = \pm 5.$ | |

10. **Symmetrical equation of the plane.**—This is the equation in terms of a, b, c , the intercepts of the plane on the axes.

Let the required equation be,

$$Ax + By + Cz = D.$$

Then, since this plane passes through the points $(a, 0, 0)$, $(0, b, 0)$, $(0, 0, c)$, we have,

$$Aa = D, \quad A = \frac{D}{a},$$

$$Bb = D, \quad B = \frac{D}{b},$$

$$Cc = D, \quad C = \frac{D}{c}.$$

Whence,
$$\frac{x}{a} + \frac{y}{b} + \frac{z}{c} = 1$$

is the required equation of the plane.

11. **Angle between the two planes** $A_1x + B_1y + C_1z + D_1 = 0$, and $A_2x + B_2y + C_2z + D_2 = 0$.—The angle between two planes is evidently equal to the angle between their normals from the origin.

The direction cosines of the latter are

$$\frac{A_1}{\sqrt{A_1^2 + B_1^2 + C_1^2}}, \quad \frac{B_1}{\sqrt{\dots}}, \quad \frac{C_1}{\sqrt{\dots}},$$

$$\frac{A_2}{\sqrt{A_2^2 + B_2^2 + C_2^2}}, \quad \frac{B_2}{\sqrt{\dots}}, \quad \frac{C_2}{\sqrt{\dots}}.$$

Hence, the angle θ between the two normals and \therefore between the planes is determined by

$$\cos \theta = \frac{A_1 A_2 + B_1 B_2 + C_1 C_2}{\sqrt{A_1^2 + B_1^2 + C_1^2} \cdot \sqrt{A_2^2 + B_2^2 + C_2^2}},$$

DISCUSSION. — (1) If the planes are parallel, their normals have the same direction cosines; and since the latter depend only on the coefficients of x , y , and z , these coefficients in both equations must be equal or proportional. Hence, the condition for parallelism is,

$$\frac{A_1}{A_2} = \frac{B_1}{B_2} = \frac{C_1}{C_2}.$$

This result is also obtainable by putting $\theta = 0$, $\cos \theta = 1$, above.

(2) If the planes be perpendicular, $\cos \theta = 0$,

$$\therefore A_1 A_2 + B_1 B_2 + C_1 C_2 = 0.$$

12. Distance from a point to a plane. — Let the given point be (x_1, y_1, z_1) , and the plane,

$$x \cos \alpha + y \cos \beta + z \cos \gamma = p.$$

Then the plane $x_1 \cos \alpha + y_1 \cos \beta + z_1 \cos \gamma = p_1$ passes through the given point and is parallel to the given plane.

But $d = p_1 - p = x_1 \cos \alpha + y_1 \cos \beta + z_1 \cos \gamma - p$.

$$\therefore d = x_1 \cos \alpha + y_1 \cos \beta + z_1 \cos \gamma - p.$$

If the given plane is $Ax + By + Cz = D$,

we have
$$d = \frac{Ax_1 + By_1 + Cz_1 - D}{\sqrt{A^2 + B^2 + C^2}}.$$

NOTE. — If this formula give a positive result, the given point and the origin are on opposite sides of the given plane; if negative, on the same side; if the numerical distance only is desired, the sign is immaterial.

EXERCISES.

1. Interpret these equations :

(1) $y = mx + c.$

(4) $2x + 3y = 0.$

(2) $z = nx + c.$

(5) $x - z = 4.$

(3) $y = mz + c.$

(6) $y + 3z = 1.$

2. Reduce to the normal and symmetrical forms, and find which octant each of these planes cuts :

(1) $4x - 5y + 2z = 9.$

(5) $-x - 2y - z = 10.$

(2) $3x + 4y - z = 5.$

(6) $-x + y - z = 4.$

(3) $5x + 5y + z = 2.$

(7) $-2x + 3y + z = 8.$

(4) $2y - 3x + z = 4.$

(8) $2y - x - z = 3.$

3. Find the intercepts of the following planes :

(1) $y + 2x - z = 3.$

(4) $-x + y - z = 2.$

(2) $2x - 5y + 3z = 5.$

(5) $x + 2y - 5z = 14.$

(3) $x + y + z = 7.$

(6) $2x - 3y - z = 10.$

4. A plane is 5 units from the origin and \perp to the line whose direction cosines are proportional to 2, 3, 5. Find its equation.

5. Find the distance from the origin to the plane whose intercepts are [1, 5, 9].

6. Find the equation of the plane passing through the points (0, -2, 4), (2, 2, 2), and (1, 0, 3).

7. Find the angle between the planes

$$\left. \begin{aligned} x - 2y + 4z &= 6 \\ 3x - y - 2 &= 0 \end{aligned} \right\} (1)$$

and that between the planes

$$\left. \begin{aligned} 2x - y + 3z &= 1 \\ x - y - 2z &= 3 \end{aligned} \right\} (2)$$

8. Show that the angles which the plane $Ax + By + Cz = D$ makes with the co-ordinate planes are

(1) $\cos^{-1} \frac{C}{\sqrt{A^2 + B^2 + C^2}}.$

(2) $\cos^{-1} \frac{B}{\sqrt{\dots\dots\dots}}$

(3) $\cos^{-1} \frac{A}{\sqrt{\dots\dots\dots}}.$

9. Find the distance from the point $(1, -2, -3)$ to the plane $2x - y + 3z = 4$.

10. Show that the plane $A(x - x_1) + B(y - y_1) + C(z - z_1) = 0$ passes through the point (x_1, y_1, z_1) and is parallel to the plane $Ax + By + Cz = D$.

11. Find the equation of the plane through the point $(2, -3, 5)$ and parallel to the plane $x + 2y - 3z = 2$.

12. What three equations must be satisfied in order that the plane $Ax + By + Cz = D$ may pass through the points (x_1, y_1, z_1) , (x_2, y_2, z_2) , and (x_3, y_3, z_3) ? If the equations differ only by constant factors, what about the three given points?

13. Find the equation of the plane through the points $(2, 0, -3)$, $(1, 0, -2)$, and \perp to the plane

$$2x - y + 2z = 4.$$

14. Find the plane through the points $(1, 2, 0)$, $(0, 3, -2)$, $(-2, 0, -4)$.

15. Find the plane through the point $(2, 2, -1)$ and \perp to each of the planes,

$$\left. \begin{array}{l} y - x - 3z = 3, \\ 2y + x + z = 9. \end{array} \right\}$$

CHAPTER III

THE STRAIGHT LINE

13. A straight line in space is generally represented by two equations of the first degree considered as simultaneous, i.e., by the intersection between two planes. The equations of any two planes through a straight line are sufficient to determine the line. The simplest planes, however, available for this purpose, are two planes [through the line] which are perpendicular to two of the co-ordinate planes, and called the **projecting planes** of the line. Thus,

$$\left. \begin{aligned} x &= mz + b, \\ y &= nz + c, \end{aligned} \right\}$$

are two planes representing a straight line; and since they are \perp to the xz and yz planes respectively, they are two of its projecting planes.

14. **Equations of the straight line through a given point and in a given direction.** — Let (x_1, y_1, z_1) be the given point and α, β, γ , the given direction angles of the line. Also, (x, y, z) is any point on the line, and d the distance between the two points,

Then,

$$\left. \begin{aligned} d \cos \alpha &= x - x_1, \\ d \cos \beta &= y - y_1, \\ d \cos \gamma &= z - z_1. \end{aligned} \right\}$$

$$\therefore \frac{x - x_1}{\cos \alpha} = \frac{y - y_1}{\cos \beta} = \frac{z - z_1}{\cos \gamma} \dots \dots \dots (1)$$

are the equations of the line.

15. Equations of the straight line through two given points (x_1, y_1, z_1) and (x_2, y_2, z_2) . — If the line (1), § 14, passes through the point (x_2, y_2, z_2) , we have,

$$\frac{x_2 - x_1}{\cos \alpha} = \frac{y_2 - y_1}{\cos \beta} = \frac{z_2 - z_1}{\cos \gamma} \dots \dots \dots (2)$$

Dividing (1) by (2), member by member, we obtain,

$$\frac{x - x_1}{x_2 - x_1} = \frac{y - y_1}{y_2 - y_1} = \frac{z - z_1}{z_2 - z_1} \dots \dots \dots (3)$$

as the required equations of the straight line through the two points.

16. To find the projecting planes of a given line. — Let the line be given by the equations,

$$A_1x + B_1y + C_1z + D_1 = 0 \} \dots \dots \dots (1)$$

$$A_2x + B_2y + C_2z + D_2 = 0 \} \dots \dots \dots (2)$$

or, for brevity, $S_1 = 0 \} \dots \dots \dots (1)$

$$S_2 = 0 \} \dots \dots \dots (2)$$

Then, the equation, $mS_1 + nS_2 = 0 \dots \dots \dots (3)$

represents any plane passing through the intersection of the planes (1) and (2). (Why?) Now, if m and n be so chosen that one of the variables will vanish, then (3) will represent one of the projecting planes of the given line.

For example, if z vanish, the resulting equation (3) will represent the plane through the line which is \perp to the xy plane. Similarly for the other projecting planes. In practice, however, we simply eliminate from the two given equations the necessary variable.

17. To find the piercing points of a given line on the coordinate planes. — Let the given line be represented by the equations,

$$x = mz + b \quad \dots \dots \dots (1)$$

$$y = nz + c \quad \dots \dots \dots (2)$$

To obtain its piercing point on the xy plane, we make $z = 0$ in (1) and (2), and solve the resulting equations for x and y . The result is $x = b, y = c$. Hence, the line meets the xy plane in the point $(b, c, 0)$. Similarly for the remaining piercing points.

18. Condition that two lines may meet.—Let the lines be given thus,

$$\left. \begin{aligned} x &= mz + b \\ y &= nz + c \end{aligned} \right\} \dots \dots \dots (1)$$

$$\left. \begin{aligned} x &= m_1z + b_1 \\ y &= n_1z + c_1 \end{aligned} \right\} \dots \dots \dots (2)$$

Suppose they meet. Then, to find their point of intersection we must solve these equations for x, y, z . But there are four equations and only three unknown quantities. Hence, the condition that the lines meet is that the co-ordinates satisfying any three of the equations should also satisfy the fourth.

Equating the values of x , and also those of y , then solving each equation for z , we obtain,

$$z = \frac{b_1 - b}{m - m_1} \dots \dots \dots (3)$$

$$z = \frac{c_1 - c}{n - n_1} \dots \dots \dots (4)$$

Hence, if the lines intersect, we have,

$$\frac{b_1 - b}{m - m_1} = \frac{c_1 - c}{n - n_1} \dots \dots \dots (5)$$

which is the required condition.

NOTE. — A line in the form

$$\frac{x - x_1}{A} = \frac{y - y_1}{B} = \frac{z - z_1}{C}$$

can be reduced to the typical form of § 14 by dividing the denominators by $\sqrt{A^2 + B^2 + C^2}$, for the results are the direction cosines of the line.

19. Angle between two lines.— Let the given lines be,

$$\frac{x - x_1}{A} = \frac{y - y_1}{B} = \frac{z - z_1}{C} \quad \dots \quad (1)$$

$$\frac{x - x_2}{A_1} = \frac{y - y_2}{B_1} = \frac{z - z_2}{C_1} \quad \dots \quad (2)$$

Then the direction cosines of the lines are,

$$\frac{A}{\sqrt{A^2 + B^2 + C^2}}, \quad \frac{B}{\sqrt{\dots}}, \quad \frac{C}{\sqrt{\dots}} \quad \dots \quad (1)$$

$$\frac{A_1}{\sqrt{A_1^2 + B_1^2 + C_1^2}}, \quad \frac{B_1}{\sqrt{\dots}}, \quad \frac{C_1}{\sqrt{\dots}} \quad \dots \quad (2)$$

Hence, the angle θ between them is determined by,

$$\cos \theta = \frac{AA_1 + BB_1 + CC_1}{\sqrt{A^2 + B^2 + C^2} \cdot \sqrt{A_1^2 + B_1^2 + C_1^2}}.$$

20. Angle between a line and a plane.— Let these be given as follows:

$$\frac{x - x_1}{A} = \frac{y - y_1}{B} = \frac{z - z_1}{C} \quad \dots \quad (1)$$

$$A_1x + B_1y + C_1z = D \quad \dots \quad (2)$$

Now, the angle between the line and the plane is the complement of the angle between the line and the normal to the plane.

The normal from the origin to the plane is

$$\frac{x}{A_1} = \frac{y}{B_1} = \frac{z}{C_1} \quad \dots \quad (3)$$

[Why?]

If ϕ is the angle between (1) and (2), and θ the angle between (1) and (3), $\sin \phi = \cos \theta$.

$$\therefore \sin \phi = \frac{AA_1 + BB_1 + CC_1}{\sqrt{A^2 + B^2 + C^2} \cdot \sqrt{A_1^2 + B_1^2 + C_1^2}},$$

DISCUSSION.—(1) If the line be parallel to the plane $\sin \phi = 0$,

$$\therefore AA_1 + BB_1 + CC_1 = 0.$$

(2) If \perp , $\sin \phi = 1$, whence,

$$\frac{A}{A_1} = \frac{B}{B_1} = \frac{C}{C_1}.$$

(3) If the line lies in the plane, the angle between them is 0, and the plane passes through the point (x_1, y_1, z_1) .

$$\therefore AA_1 + BB_1 + CC_1 = 0,$$

and $A_1x_1 + B_1y_1 + C_1z_1 = D.$

NOTE 1.— Referring to the result of § 19, if the lines are parallel,

$$\frac{A}{A_1} = \frac{B}{B_1} = \frac{C}{C_1},$$

and if \perp , $AA_1 + BB_1 + CC_1 = 0.$

NOTE 2.— The \perp from the point (x_1, y_1, z_1) to the plane

$$A_1x + B_1y + C_1z = D \text{ is evidently}$$

$$\frac{x - x_1}{A_1} = \frac{y - y_1}{B_1} = \frac{z - z_1}{C_1},$$

for this line passes through the given point, and has the same direction cosines as the normal from the origin to the given plane.

21. If a line in space is \perp to a plane, its projections are perpendicular to the traces* of the plane.— Let any plane be $Ax + By + Cz = D.$

Then its traces are,

$$Ax + By = D \dots \dots \dots (1)$$

$$By + Cz = D \dots \dots \dots (2)$$

$$Ax + Cz = D \dots \dots \dots (3)$$

Also, the \perp from the origin to the plane is

$$\frac{x}{A} = \frac{y}{B} = \frac{z}{C},$$

* The traces of a plane are its lines of intersection with the co-ordinate planes. The projections of a line are the lines of intersection of its projecting planes with the co-ordinate planes.

and its projections are

$$\left. \begin{aligned} Bx - Ay &= 0 \\ Cy - Bz &= 0 \\ Cx - Az &= 0 \end{aligned} \right\} \dots \dots \dots (4)$$

But the lines (4) are evidently \perp [respectively] to (1), (2), and (3). \therefore , etc.

22. To pass a plane through a given point and a given line. — Let these be given thus :

$$(x_2, y_2, z_2) \text{ and } \frac{x - x_1}{A_1} = \frac{y - y_1}{B_1} = \frac{z - z_1}{C_1}.$$

Now let the required plane be

$$Ax + By + Cz = D \dots \dots \dots (1)$$

Then, since it must pass through the given point,

$$\therefore Ax_2 + By_2 + Cz_2 = D \dots \dots \dots (2)$$

and through the given line,

$$\therefore AA_1 + BB_1 + CC_1 = 0 \dots \dots \dots (3)$$

and

$$Ax_1 + By_1 + Cz_1 = D \dots \dots \dots (4)$$

Now eliminate A, B, C, and D from (1), (2), (3) and (4), etc., to obtain the equation of the required plane.

EXERCISES ON CHAPTER III.

1. Find the positions of the following lines :

$$\left. \begin{aligned} 3x + 4y - z &= 4 \\ x - 2y + 3z &= 10 \end{aligned} \right\}, \left. \begin{aligned} 2x - y &= 1 \\ 3y - 2z &= 3 \end{aligned} \right\}, \left. \begin{aligned} y &= 2 \\ z &= -3 \end{aligned} \right\}, \left. \begin{aligned} x &= 1 \\ y &= 4 \end{aligned} \right\}, \left. \begin{aligned} x &= -1 \\ z &= 3 \end{aligned} \right\}.$$

2. Find the equation of the line through the points (2, 4, -5), (3, -2, -9). Determine its piercing points.

3. Two projecting planes of a line are

$$\left. \begin{aligned} 2x - 3y - 3 &= 0, \\ x - 2z - 4 &= 0. \end{aligned} \right\} \text{ Find the third.}$$

4. Find the angles between the lines

$$\frac{x}{2} = \frac{y}{3} = \frac{z}{0}$$

and

$$\frac{x}{3} = \frac{y}{-4} = \frac{z}{1}.$$

Also, between the lines

$$2z + y - 2x - 3 = 0, \}$$

$$3y + z - 3x - 5 = 0, \}$$

and

$$y - 3x - 4 = 0, \}$$

$$2z - 5x - 5 = 0. \}$$

5. Show that the lines

$$\left. \begin{aligned} 3x + 2y + z - 5 = 0, \\ x + y - 2z - 3 = 0, \end{aligned} \right\} \text{ and } \left. \begin{aligned} 2x - y - z = 0, \\ 7x + 10y - 8z = 0, \end{aligned} \right\}$$

are perpendicular.

6. Find the equations of the line through the point
- $(1, -2, -5)$
- and
- \parallel
- to the line

$$z - y + 2x + 3 = 0, \}$$

$$z - 3x + 5y - 1 = 0. \}$$

7. Find the equations of the line through the point
- $(1, 2, 3)$
- and
- \perp
- to the plane

$$x + 4y - 2z - 8 = 0.$$

8. Prove that if two lines are parallel, their projections are parallel.

9. Find the angle between the line

$$\frac{x-1}{2} = \frac{y+3}{-1} = \frac{z-6}{-3}$$

and the plane

$$3x - 4y + 5z - 2 = 0.$$

10. Show that the three planes,

$$2x - 3y + z + 1 = 0, \}$$

$$5x + z - 1 = 0, \}$$

$$19x - 3y - 4z - 5 = 0, \}$$

are concurrent in one straight line.

CHAPTER IV

SURFACES. SURFACES OF REVOLUTION

23. A single equation in three variables, some of which may be absent, represents a surface.—Take the equation $f(x, y, z) = 0$. This expresses the condition satisfied by the co-ordinates of all points on its locus, *i. e.*, the law governing the motion of a point in space. Now these points [or the various positions of one moving point], as it were, cannot lie scattered indiscriminately in space, since at any moment their co-ordinates must satisfy the given equation. Hence, the given equation cannot represent a solid. It therefore represents a surface.

Again, take $f(x, y) = 0$. In the plane xy this equation represents a curve. Now, if a line \perp to this plane move parallel to itself, so that one of its extremities traces out the curve in the plane, the line will generate a cylindrical surface, and it is obvious that the co-ordinates of any point on the moving line always satisfy the given equation. Hence, a single equation in two variables represents a cylinder.

Finally, take $f(x) = 0$. This evidently represents a plane \perp to the x -axis, or, when its sinister is factorable, it represents a series of parallel planes. \therefore , etc.

EXERCISES.

What loci in space are represented by the following equations ?

(1) $x^2 + y^2 = 25$.

(3) $y^2 = 12z$.

(2) $z^2 + x^2 = 9$.

(4) $(x - 2)^2 = 12(y + 3)^2$.

(5) $\frac{x^2}{9} + \frac{y^2}{4} = 1.$

(7) $x^2 - y^2 = 0.$

(8) $x^3 - 2x^2 - 5x + 6 = 0.$

(6) $\frac{x^2}{25} - \frac{y^2}{16} = 1.$

(9) $(x - 4)(y + 3) = 0.$

(10) $xyz(x^2 - 2x + 1) = 0.$

24. Surfaces of revolutions. Definitions.—These surfaces are generated by the revolution of a curve, the **generatrix** about a fixed axis, the **axis of revolution**. A section of the surface by a plane through this axis is called a **meridian section**. It is clearly equal to the generating curve. A section \perp to the axis is a **right section**, and by definition is a circle. The **traces** of a surface are its intersections with the co-ordinate planes.

25. General equation of a surface of revolution.—Let ABC' be the generating curve [in the plane xz], and let the

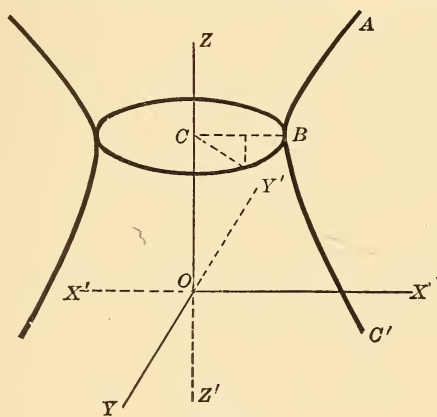

Fig. 159.

z -axis be the axis of revolution. Let BDE be any right section of the surface. Put $CB = a$ [= CF].

Then, for any point on this section, $x^2 + y^2 = a^2$.

But a is the x of the point B before the rotation.

Hence we must find x from the equation of the generating curve $f(x, z) = 0$, and substitute for a .

$$\therefore x^2 + y^2 = f(z) \dots (\lambda)$$

is the equation required.

If the revolution is about the y -axis, we have

$$x^2 + z^2 = f(y), \text{ etc.}$$

We shall use equation (λ) as the general equation of a surface of revolution.

26. Equations of various surfaces. —

(1) The sphere.

Here, generatrix is $x^2 + z^2 = r^2$.

$$\therefore x^2 = r^2 - z^2 = f(z).$$

$$\therefore x^2 + y^2 + z^2 = r^2$$

is the equation of the sphere.*

(2) The paraboloid of revolution.

Here, generatrix is $x^2 = 4az$.

$$\therefore f(z) = 4az, \quad \therefore x^2 + y^2 = 4az$$

is the equation of the paraboloid of revolution.

(3) The ellipsoid of revolution.

(a) Prolate spheroid.

Here, generatrix is $\frac{x^2}{b^2} + \frac{z^2}{a^2} = 1$ [revolution about major axis].

$$\therefore \frac{x^2}{b^2} + \frac{y^2}{b^2} + \frac{z^2}{a^2} = 1$$

is the equation required.

(β) Oblate spheroid.

Here, generatrix is $\frac{x^2}{a^2} + \frac{z^2}{b^2} = 1$ [revolution about minor axis].

* If center is at (h, k, l) , the equation becomes

$$(x - h)^2 + (y - k)^2 + (z - l)^2 = r^2.$$

$$\therefore \frac{x^2}{a^2} + \frac{y^2}{a^2} + \frac{z^2}{b^2} = 1$$

is the equation required.

(4) The hyperboloid of revolution.

(a) Hyperboloid of one sheet [revolution about conjugate axis]. Its equation is found to be

$$\frac{x^2}{a^2} + \frac{y^2}{a^2} - \frac{z^2}{b^2} = 1,$$

either directly, or by putting $-b^2$ for b^2 in the equation of the oblate spheroid.

(β) Hyperboloid of two sheets [revolution about transverse axis].

Its equation is

$$\frac{x^2}{b^2} + \frac{y^2}{b^2} - \frac{z^2}{a^2} = 1.$$

(5) The cone of revolution.

Here, generatrix is $z = mx + c$.

$$\therefore f(z) = \left[\frac{z - c}{m} \right]^2.$$

$$\therefore m^2 (x^2 + y^2) = (z - c)^2$$

is the equation required.

27. Discussions of these equations.—

(1) All plane sections \parallel to the co-ordinate planes are circles. Also, the equation remains unaltered by any rotation of the axes. \therefore all plane sections of a sphere are circles.

(2) All plane sections \parallel to the xz and yz planes are parabolas. Those \parallel to the xy plane are circles.

(3) (a) The surface lies between the tangent planes

$$x = \pm b, \quad y = \pm b, \quad z = \pm a.$$

Its traces on the xz and yz planes are ellipses.

(β) Surface lies between the tangent planes

$$x = \pm a, y = \pm a, z = \pm b.$$

Traces on the xz and yz planes are ellipses.

If $b = a$, the equation reduces to that of the sphere.

(4) (a) Sections \parallel to the yz and xz planes are hyperbolas. The smallest circular section [\parallel to xy plane] is the trace on the xy plane, and is called the "gorge circle."

The planes $x = \pm a$, each cut two intersecting straight lines on the surface.

(β) Sections \parallel to xz and yz planes are hyperbolas.

(5) Sections \parallel to the xz and yz planes are hyperbolas.

If $c = 0$, the equation becomes,

$$m(x^2 + y^2) = z^2.$$

Hence, any section parallel to the axis of the cone is an hyperbola; any section through the axis consists of two intersecting straight lines.

28. Sections of a cone. — We propose to determine the

nature of any section of a cone by finding its equation referred to a pair of axes in the secant plane.

APB is any section of a cone, through the y -axis and $\therefore \perp$ to the xz plane.

Let OB and OY be the axes of reference. Also P is any point on the section, whose co-ordinates in space are (x, y, z) ; and referred to OB, OY, in plane ABP, its co-ordinates are (x_1, y_1) .

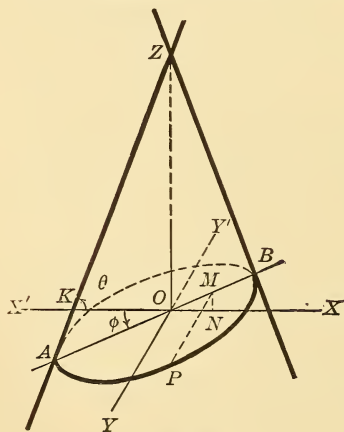

Fig. 160.

Let $\angle XOB = \phi$, $\angle OKZ = \theta$.

Then, draw $PM \perp OB$, $MN \perp OX$.

Now, $ON = OM \cos \phi$, $MN = OM \sin \phi$,

or $x = x_1 \cos \phi$, $z = x_1 \sin \phi$,
 $y = PM = y$ [since $PM \perp xz$ plane].

Substituting these values for x, y, z , in the equation of the cone,
 $[m^2(x^2 + y^2) = (z - c)^2]$;

and noting that $m = \tan \theta$, we obtain

$$\tan^2 \theta [x_1^2 \cos^2 \phi + y_1^2] = [x_1 \sin \phi - c]^2.$$

Or, performing indicated operations, and omitting the subscripts, we obtain,

$$y^2 \tan^2 \theta + x^2 [\cos^2 \phi \tan^2 \theta - \sin^2 \phi] + 2cx \sin \phi - c^2 = 0.$$

Putting $\cos^2 \phi \tan^2 \theta$ for $\sin^2 \phi$, we finally get,

$$y^2 \tan^2 \theta + x^2 \cos^2 \phi [\tan^2 \theta - \tan^2 \phi] + 2cx \sin \phi - c^2 = 0,$$

which is the equation of the section referred to OB and OY in its own plane.

Comparing this equation with the general equation of the second degree (Plane Geometry), we write,

$$\Sigma = \cos^2 \phi \tan^2 \theta [\tan^2 \theta - \tan^2 \phi].$$

$$\Delta = c^2 \{ \cos^2 \phi \tan^2 \theta [\tan^2 \theta - \tan^2 \phi] + \tan^2 \theta \sin^2 \phi \}$$

DISCUSSION. — (1) Let $c \neq 0$.

If $\phi < \theta$, $\Sigma > 0$, $\Delta \neq 0$,

\therefore section is an ellipse.

(2) If $\phi = \theta$, $\Sigma = 0$, $\Delta \neq 0$,

\therefore section is a parabola.

(3) If $\phi > \theta$, $\Sigma < 0$, $\Delta \neq 0$,

\therefore section is an hyperbola.

(4) If $c = 0$, $\Delta = 0$,

\therefore when the secant plane passes through the vertex of the cone, the sections (1), (2), and (3) reduce to a point, a straight line, and two intersecting straight lines, respectively.

(5) If $\phi = 0$, secant plane is \perp to axis of cone, and above equation becomes

$$x^2 + y^2 = c^2 \cot^2 \theta \text{ [a circle].}$$

(6) If $c = \infty$, cone becomes a cylinder, and a section parallel to an element is two parallel lines; or one line when plane touches the surface.

29. Quadrics. General equation of the second degree in three variables. — This may be written,

$$\begin{aligned} Ax^2 + By^2 + Cz^2 + 2Hxy + 2Gxz + 2Fyz + 2Ix \\ + 2Jy + 2Kz + L = 0, \end{aligned}$$

and the loci which it may represent are called quadric surfaces, or simply quadrics.

Put $z = \lambda$, or $z = 0$, and the results are conics.

Hence, all sections \parallel to xy plane are conics. Also, by transformation of co-ordinates, the plane xy may become one of the series of parallel secant planes, while the degree of the above equation remains unaltered. \therefore all \parallel plane sections of a quadric are similar conics.

30. Special forms. — By transformation of co-ordinates the general equation may be reduced to one of the following forms, viz.,

$$\left. \begin{aligned} Ax^2 + By^2 + Cz^2 + L = 0, \\ Ax^2 + By^2 + 2Kz = 0. \end{aligned} \right\}$$

The former represents central quadrics, the latter non-central quadrics.

If the intercepts of these quadrics on the co-ordinate axes are a , b , and c , the former may be written in one of the three following forms, depending on the signs of the coefficients.

$$\frac{x^2}{a^2} + \frac{y^2}{b^2} + \frac{z^2}{c^2} = 1 \quad (1)$$

$$\frac{x^2}{a^2} + \frac{y^2}{b^2} - \frac{z^2}{c^2} = 1 \quad \dots \dots \dots (2)$$

$$\frac{x^2}{a^2} - \frac{y^2}{b^2} - \frac{z^2}{c^2} = 1 \quad \dots \dots \dots (3)$$

or, also,

$$\frac{x^2}{a^2} + \frac{y^2}{b^2} + \frac{z^2}{c^2} = 0 \quad \dots \dots \dots (4)$$

$$\frac{x^2}{a^2} + \frac{y^2}{b^2} - \frac{z^2}{c^2} = 0 \quad \dots \dots \dots (5)$$

where the constant term $L = 0$.

The second equation above, non-central quadrics, may be written in the two following forms:

$$\frac{x^2}{a^2} + \frac{y^2}{b_2} = z \quad \dots \dots \dots (6)$$

$$\frac{x^2}{a^2} - \frac{y^2}{b^2} = z \quad \dots \dots \dots (7)$$

but a, b , are no longer intercepts in these two equations.

DISCUSSIONS.—(1) (α) Traces on each of co-ordinate planes are ellipses.

(β) Sections \parallel to any co-ordinate plane are similar ellipses.

(γ) Surface lies between the tangent planes

$$x = \pm a, y = \pm b, z = \pm c.$$

(δ) If $a = b$, the surface is the oblate or prolate spheroid, according as $a > \text{or} < c$.

The surface may be generated by a variable ellipse moving \parallel to the xy plane.

It is called the **ellipsoid**.

(2) (α) Trace on xy plane is an ellipse ; on yz, xz , planes, hyperbolas.

(β) Sections \parallel to xy plane are similar ellipses ; those parallel to yz, xz , planes are hyperbolas.

(γ) Smallest elliptic section is the trace on the xy plane, semi-axes a and b .

This surface is called the **hyperboloid of one sheet**.

(δ) If $a = b$, it becomes the hyperboloid of revolution.

- (3) (α) Traces on the xy and xz planes are hyperbolas.
 (β) Sections parallel to these planes are hyperbolas.
 (γ) Sections parallel to yz -plane are ellipses.
 (δ) No part of the surface lies between the planes $x = \pm a$.
 (4) This equation represents the point $(0, 0, 0)$.
 (5) This equation represents a cone.
 (α) Origin is a point on the locus.
 (β) Trace on xy plane is a point.

Sections parallel to xy plane are similar ellipses.

(γ) Traces on xz and yz planes are each a pair of straight lines intersecting at the origin.

(δ) The surface is symmetrical with respect to each of the co-ordinate planes and \therefore with respect to the origin as a center. Hence it is a central quadric.

(6) (α) Sections parallel to xy plane are ellipses; the xy plane is tangent at the origin to the surface, and the latter lies above it.

(β) Sections parallel to the xz and yz planes are parabolas, having the z -axis as their common axis and running upward.

This surface is known as the **elliptic paraboloid**.

(7) (α) Traces on xz and yz planes are parabolas; axes lie on z -axis, and they run in opposite directions.

(β) Sections parallel to these planes are also parabolas whose axes run in opposite directions.

(δ) Sections parallel to the xy -plane are hyperbolas. Trace on this plane consists of two intersecting straight lines.

NOTE. — Several minor details in these surfaces, such as directions of axes, etc., are left for the student to discuss.

The last surface is known as the **hyperbolic paraboloid**.

EXERCISES ON CHAPTER IV.

1. Show that two spheres intersect in a circle.
2. Show that the cone $\frac{x^2}{a^2} - \frac{y^2}{b^2} - \frac{z^2}{c^2} = 0$ is asymptotic to the hyperboloid $\frac{x^2}{a^2} - \frac{y^2}{b^2} - \frac{z^2}{c^2} = 1$.
3. Show the same of the cone $\frac{x^2}{a^2} + \frac{y^2}{b^2} - \frac{z^2}{c^2} = 0$ and the hyperboloid $\frac{x^2}{a^2} + \frac{y^2}{b^2} - \frac{z^2}{c^2} = 1$.

4. Find the plane tangent to the sphere

$$(x - a)^2 + (y - b)^2 + (z - c)^2 = r^2 \text{ at } (x_1, y_1, z_1).$$

$$\text{Ans. } (x - a)(x_1 - a) + (y - b)(y_1 - b) + (z - c)(z_1 - c) = r^2.$$

$$\text{Also, } (x - x_1)(a - x_1) + (y - y_1)(b - y_1) + (z - z_1)(c - z_1) = 0.$$

5. Find equation of tangent plane to sphere
- $x^2 + y^2 + z^2 = a^2$
- at
- (x_1, y_1, z_1)
- .

$$\text{Ans. } xx_1 + yy_1 + zz_1 = a^2.$$

6. Find the equation of the tangent plane to the quadric

$$Ax^2 + By^2 + Cz^2 + L = 0 \text{ at } (x_1, y_1, z_1).$$

$$\text{Ans. } Ax_1x + By_1y + Cz_1z + L = 0.$$

7. Find the traces of the surface
- $2x^2 + 3y^2 - 6z^2 + 3 = 0$
- .

8. Find the projecting cylinders of the curve

$$\left. \begin{aligned} 2x^2 + 3y^2 - 4z^2 - 1 &= 0, \\ 3x^2 - y^2 + z^2 + 3 &= 0. \end{aligned} \right\}$$

9. Find the loci in space represented by the equations

$$(1) \ 3(x^2 + y^2) = \sqrt{2}, \quad (3) \ 2x^2 - 5y^2 = 10.$$

$$(2) \ 3x^2 - 5y^2 = 15, \quad (4) \ (y - 1)^2 = 12(x + 3).$$

$$(5) \ (x^2 - 2x + 4)(x^2 + 3x + 1) = 0.$$

EXERCISES FOR ADVANCED STUDENTS.

1. A cone of revolution whose vertical angle = 90° is cut by a plane \parallel to one touching the slant height. Show that the latus rectum of the section is equal to twice its distance from the vertex.

2. At what angle must a plane be inclined to the base of a cone in order to cut a rectangular hyperbola? Determine the least vertical angle of the cone for which this is possible.

3. Show that any oblique section of a cylinder of revolution is an ellipse.

4. Determine the axes of the ellipse when the radius of base of cylinder is given, and the inclination of the cutting plane to the axis of the cylinder.

5. A right circular cylinder is cut by a plane at an angle ϕ to its axis. Find the eccentricity of the section.

$$\text{Ans. } e = \cos \phi.$$

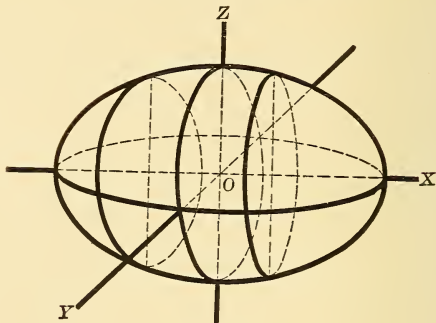

Fig. 165,

The Ellipsoid, $\frac{x^2}{a^2} + \frac{y^2}{b^2} + \frac{z^2}{c^2} = 1$.

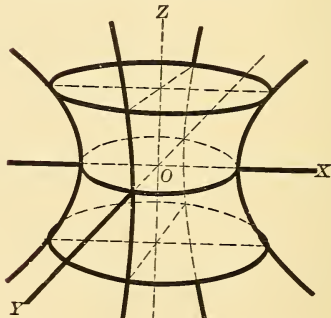

Fig. 166,

The Hyperboloid of one sheet, $\frac{x^2}{a^2} + \frac{y^2}{b^2} - \frac{z^2}{c^2} = 1$.

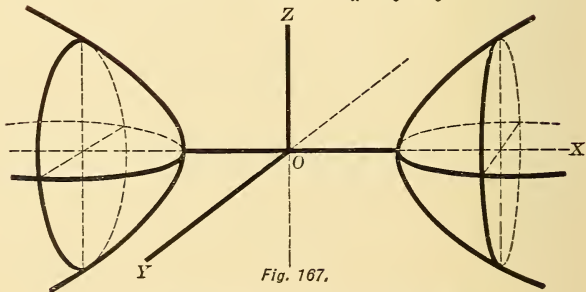

Fig. 167,

The Hyperboloid of two sheets, $\frac{x^2}{a^2} - \frac{y^2}{b^2} - \frac{z^2}{c^2} = 1$.

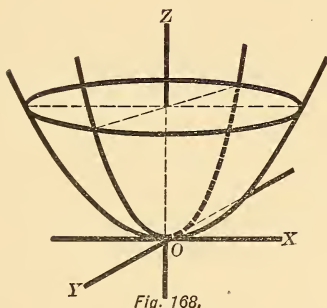

Fig. 168.

The Elliptic Paraboloid, $\frac{x^2}{a^2} + \frac{y^2}{b^2} = z$.

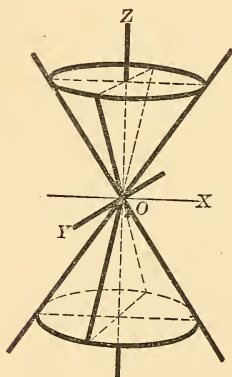

Fig. 169.

The Cone, $\frac{x^2}{a^2} + \frac{y^2}{b^2} - \frac{z^2}{c^2} = 0$.

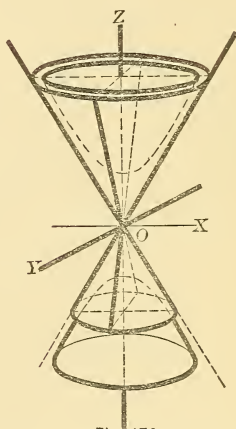

Fig. 170.

The Hyperboloid and its asymptotic Cone.

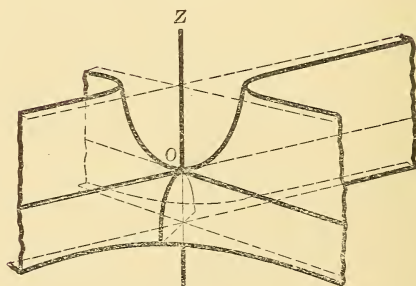

Fig. 171.

The Hyperbolic paraboloid, $\frac{x^2}{a^2} - \frac{y^2}{b^2} = z$.

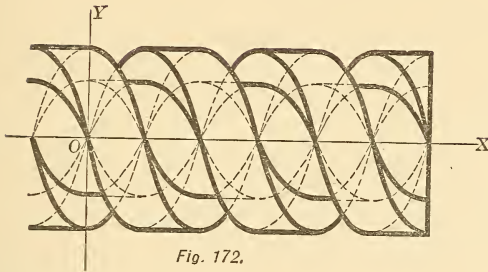

Fig. 172.

The Graph of the equations,

$$\left. \begin{aligned} y &= \pm b \sin 2\pi \frac{x}{a} \\ y &= \pm b \cos 2\pi \frac{x}{a} \end{aligned} \right\} \text{for two values of } b, \text{ representing} \\ \text{the plan of the spirals of a double} \\ \text{threaded screw of pitch } a.$$

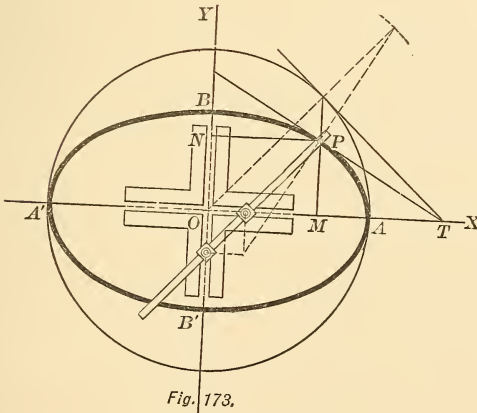

Fig. 173.

The Elliptic Compass.

APPENDIX

NOTE 1. — Area of a polygon in terms of the co-ordinates of its vertices $(x_1, y_1), (x_2, y_2),$ etc.

CASE I. Origin within the polygon.

$$\begin{aligned} \text{Area ABCDE} &= \triangle OAB + \triangle OBC + \triangle OCD + \text{etc.} \\ &= \frac{1}{2} \{ [x_2y_1 - x_1y_2] + [x_3y_2 - x_2y_3] + \text{etc.} \}. \end{aligned}$$

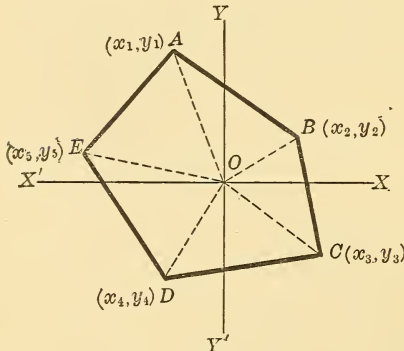

Fig. 161.

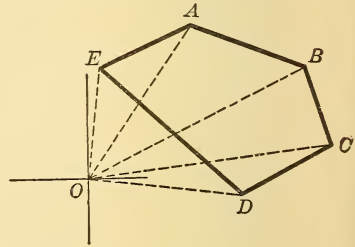

Fig. 162.

CASE II. Origin without the polygon.

$$\text{Area ABCDE} = \triangle_s OAB + \triangle OBC + \triangle OCD + \triangle OAE - \triangle ODE.$$

$$\text{But } \triangle ODE = -\frac{1}{2} [x_5y_4 - x_4y_5].$$

Hence, in all cases, the signs of the \triangle s are positive.

$$\begin{aligned} \therefore \text{Area ABCDE} &= \frac{1}{2} \{ [x_2y_1 - x_1y_2] + [x_3y_2 - x_2y_3] \\ &\quad + [x_4y_3 - x_3y_4] + \text{etc.} \} \\ &= \frac{1}{2} \{ x_2y_1 - x_1y_2 + x_3y_2 - x_2y_3 \\ &\quad + x_4y_3 - x_3y_4 + \text{etc.} \}. \end{aligned}$$

The order of the subscripts is cyclic.

The student should prove the generality of this theorem by taking various other positions of the polygon.

NOTE 2. — Eccentric angle of a point on the hyperbola.

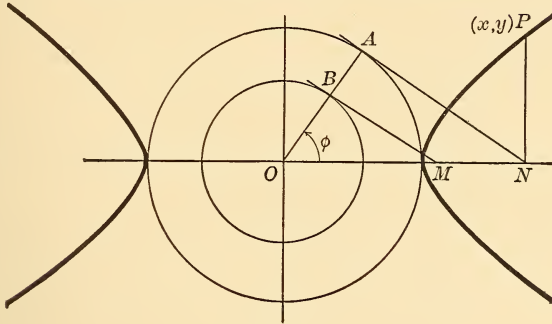

Fig. 163.

Let P be any point on the hyperbola, PN its ordinate. Describe the auxiliary circles,

$$x^2 + y^2 = a^2 \dots \dots \dots (1)$$

$$x^2 + y^2 = b^2 \dots \dots \dots (2)$$

From N draw NA tangent to circle (1). Draw OA. Then $\angle AOM = \phi$, is the eccentric angle of P.

Now,

$$x = ON = a \sec \phi.$$

$$y = PN = b \tan \phi$$

[by substitution in $\frac{x^2}{a^2} - \frac{y^2}{b^2} = 1$].

But $BM = b \tan \phi. \therefore BM = PN.$

The point $[a \sec \phi, b \tan \phi]$ evidently satisfies the equation of the hyperbola

$$\frac{x^2}{a^2} - \frac{y^2}{b^2} = 1.$$

Hence the co-ordinates of a point on the hyperbola, as on the ellipse, may be given in terms of the variable parameter ϕ , called the eccentric angle of the point.

NOTE 3. — *Distance between two points in terms of their polar co-ordinates, found by transformation from rectangular co-ordinates. See § 8.*

Let A be (x_1, y_1) , B (x_2, y_2) .

$$\text{Then} \quad \left. \begin{array}{l} x_1 = \rho_1 \cos \theta_1 \\ y_1 = \rho_1 \sin \theta_1 \end{array} \right\}, \quad \left. \begin{array}{l} x_2 = \rho_2 \cos \theta_2 \\ y_2 = \rho_2 \sin \theta_2 \end{array} \right\}$$

$$\begin{aligned} \therefore \overline{AB}^2 &= (x_2 - x_1)^2 + (y_2 - y_1)^2 \\ &= [\rho_2 \cos \theta_2 - \rho_1 \cos \theta_1]^2 + [\rho_2 \sin \theta_2 - \rho_1 \sin \theta_1]^2 \\ &= \rho_1^2 [\cos^2 \theta_1 + \sin^2 \theta_1] + [\rho_2^2 \cos^2 \theta_2 + \sin^2 \theta_2] \\ &\quad - 2 \rho_1 \rho_2 [\cos \theta_1 \cos \theta_2 + \sin \theta_2 \sin \theta_1] \\ &= \rho_1^2 + \rho_2^2 - 2 \rho_1 \rho_2 \cos (\theta_1 - \theta_2) \end{aligned}$$

NOTE 4. — **Sign of the area of a triangle.**

See Fig. § 8, case III. Also Ex. 2, page 19.

$$\begin{aligned} \text{Area OAB} &= \frac{1}{2} \text{OA} \cdot \text{OB} \sin \text{AOB.} \\ &= \frac{1}{2} \rho_1 \rho_2 \sin (\theta_2 - \theta_1) \end{aligned}$$

This result is **positive** or **negative** according as $(\theta_2 - \theta_1)$ is positive or negative. Hence, it is seen that if we go around the $\triangle \text{OAB}$ in the order in which O, A, B are mentioned; then if this order is clockwise $(\theta_2 - \theta_1)$ is positive; otherwise it is negative.

Now in Fig. 19, § 11, take A for pole, AD for initial line. Let B be (ρ_1, θ_1) and C (ρ_2, θ_2) .

$$\text{Then} \quad \left. \begin{array}{l} x_2 - x_1 = \rho_1 \cos \theta_1 \\ y_2 - y_1 = \rho_1 \sin \theta_1 \end{array} \right\}, \quad \left. \begin{array}{l} x_3 - x_1 = \rho_2 \cos \theta_2 \\ y_3 - y_1 = \rho_2 \sin \theta_2 \end{array} \right\}$$

$$\therefore \begin{vmatrix} x_1 & y_1 & 1 \\ x_2 & y_2 & 1 \\ x_3 & y_3 & 1 \end{vmatrix} = \begin{array}{l} (x_2 - x_1)(y_3 - y_1) - (x_3 - x_1)(y_2 - y_1) \\ = \rho_1 \cos \theta_1 \cdot \rho_2 \sin \theta_2 - \rho_2 \cos \theta_2 \cdot \rho_1 \sin \theta_1 \\ = -\rho_1 \rho_2 \sin (\theta_1 - \theta_2) \end{array}$$

is **positive** or **negative** according as in traversing the perimeter of $\triangle \text{ABC}$ from A to B, from B to C, and from C to A the order is **counter-clockwise** or **clockwise**.

$$\therefore \text{ABC} = \pm \frac{1}{2} \begin{vmatrix} x_1 & y_1 & 1 \\ x_2 & y_2 & 1 \\ x_3 & y_3 & 1 \end{vmatrix},$$

the **upper** or **lower** sign prevailing according as the order is **counter-clockwise** or **clockwise**. If the vertices of the triangle are (o, o) , (x_1, y_1) , (x_2, y_2) ,

$$\begin{aligned} \Delta &= \frac{1}{2} [x_2 y_1 - x_1 y_2] \\ &= \frac{1}{2} [\rho_1 \sin \theta \cdot \rho_2 \cos \theta_2 - \rho_1 \cos \theta_1 \cdot \rho_2 \sin \theta_2] \\ &= \frac{1}{2} \rho_1 \rho_2 \sin (\theta_1 - \theta_2) \end{aligned}$$

Hence, the area of the Δ is positive or negative according as the order of (o, o) , (x_1, y_1) , (x_2, y_2) is clockwise or counter-clockwise.

NOTE 5. — *If a variable circle cut two given fixed circles at constant angles α and β , then it cuts any co-axial circle at a constant angle γ .*

Let the given circles be

$$x^2 + y^2 + 2 G_1 x + 2 F_1 y + C_1 = 0 \quad \text{or } S_1 = 0,$$

and $x^2 + y^2 + 2 G_2 x + 2 F_2 y + C_2 = 0 \quad S_2 = 0.$

Their radii are r_1 and r_2 .

Let the variable circle be

$$x^2 + y^2 + 2 G x + 2 F y + C = 0, \text{ radius } R.$$

Now $S_1 + \lambda S_2 = 0$ (radius, r)

is any co-axial circle of the first two.

or $x^2 + y^2 + 2 \frac{G_1 + \lambda G_2}{1 + \lambda} x + 2 \frac{F_1 + \lambda F_2}{1 + \lambda} y + \frac{C_1 + \lambda C_2}{1 + \lambda} = 0.$

Hence the formula for $\cos \gamma$ gives

$$2 R r \cos \gamma = 2 G \frac{G_1 + \lambda G_2}{1 + \lambda} + 2 F \frac{F_1 + \lambda F_2}{1 + \lambda} - \frac{C_1 + \lambda C_2}{1 + \lambda} - C.$$

$$\begin{aligned} \therefore 2 r r_2 \cos \gamma (1 + k) &= 2 G G_1 + 2 F F_1 - C_1 - C \\ &\quad + \lambda [2 G G_2 + 2 F F_2 - C - C] \\ &= 2 R r_1 \cos \alpha + 2 \lambda R r_2 \cos \beta. \end{aligned}$$

$$\therefore (1 + \lambda) r_1 \cos \gamma = r_1 \cos \alpha + \lambda r_2 \cos \beta.$$

This formula shows that γ is constant.

NOTE 6. — *A system of circles which cuts orthogonally two given circles has a common radical axis, i.e. is co-axial.*

Let the given circles be

$$x^2 + y^2 + 2 G_1 x + 2 F_1 y + C_1 = 0$$

$$x^2 + y^2 + 2 G_2 x + 2 F_2 y + C_2 = 0$$

and $x^2 + y^2 + 2 G x + 2 F y + C = 0 \dots \dots \dots (1)$

one of the orthogonal circles.

$$\therefore 2 G G_1 + 2 F F_1 - C_1 - C = 0 \dots \dots \dots (2)$$

$$2 G G_2 + 2 F F_2 - C_2 - C = 0 \dots \dots \dots (3)$$

Eliminate G and F from (1), (2) and (3).

\therefore (1) may be replaced by

$$\begin{vmatrix} x & y & x^2 + y^2 + C \\ G_1 & F_1 & -C_1 - C \\ G_2 & F_2 & -C_2 - C \end{vmatrix} = 0,$$

or
$$\begin{vmatrix} x & y & x^2 + y^2 \\ G_1 & F_1 & -C_1 \\ G_2 & F_2 & -C_2 \end{vmatrix} + C \begin{vmatrix} x & y & 1 \\ G_1 & F_1 & -1 \\ G_2 & F_2 & -1 \end{vmatrix} = 0.$$

If C varies this represents a circle of a co-axial system whose common radical axis is

$$\begin{vmatrix} x & y & 1 \\ G_1 & F_1 & -1 \\ G_2 & F_2 & -1 \end{vmatrix} = 0.$$

i.e. the line joining the centers of the two given circles.

COR. It is easily seen that the center of the circle which cuts three given circles orthogonally is their radical center.

NOTE 7. — *The polar of a limiting point of a co-axial system is the same for every circle of the system.*

The polar of $(k, 0)$ with respect to the circle

$$x^2 + y^2 + 2\lambda x + k^2 = 0$$

is

$$kx + \lambda(x + k) + k^2 = 0$$

or

$$(x + k)(\lambda + k) = 0, \text{ or } x + k = 0,$$

which is the line through the other limiting point and parallel to the radical axis.

NOTE 8. — JOACHIMSTHAL'S *method of finding the equation of the tangents to a given curve drawn from an external point.*

We shall illustrate it by finding the tangents to the circle $x^2 + y^2 = r^2$. Let (x_1, y_1) be the given external point, and (x_2, y_2) any other point such that the line joining these is cut by the circle. Let $m : n$ be the ratio of this section. Hence, the values

$$x = \frac{mx_2 + nx_1}{m + n}, \quad y = \frac{my_2 + ny_1}{m + n}$$

must satisfy

$$x^2 + y^2 = r^2.$$

$$\therefore (mx_2 + nx_1)^2 + (my_2 + ny_1)^2 = r^2(m + n)^2.$$

$$\therefore m^2[x_2^2 + y_2^2 - r^2] + 2mn[x_1x_2 + y_1y_2 - r^2] + n^2[x_1^2 + y_1^2 - r^2] = 0.$$

This quadratic determines the values of $m : n$ corresponding to the two points where the line cuts the circle. It has equal roots, *i.e.* the line touches the circle if

$$[x_1^2 + y_1^2 - r^2][x_2^2 + y_2^2 - r^2] = [x_1x_2 + y_1y_2 - r^2]^2.$$

This is true if (x_2, y_2) is any point on either tangent from (x_1, y_1) .

Hence, writing x, y , for x_2, y_2 , we obtain the equation to the pair of tangents from (x_1, y_1) viz :

$$[x_1^2 + y_1^2 - r^2][x^2 + y^2 - r^2] = [xx_1 + yy_1 - r^2]^2.$$

This is Joachimsthal's method with some modification by the author. It is also applicable to the conic sections.

NOTE 9. — *Solution of problems in Maxima and Minima by means of the ellipse.*

EXAMPLE 1. — Find a point P in a $\triangle ABC$ such that PA + PB + PC is a minimum.

Suppose the sum PB + PC is given ; then P is constrained to move on an ellipse whose foci are B and C ; and then AP is a minimum when AP is a normal to the ellipse at P, and \therefore makes equal angles with BP and CP. By symmetry, AP, BP and CP make \angle s of 120° with each other when AP + BP + CP is a minimum. P is easily found by Elementary Plane Geometry. The problem is impossible when any angle of the $\triangle ABC$ is greater than 120° ; but a point P can be found outside the \triangle fulfilling the requirement.

EX. 2. — Inscribe a $\triangle DEF$ of minimum perimeter in the $\triangle ABC$.

HINT. — By similar reasoning show that FD and DE make equal angles with BC, DE and EF make equal angles with CA, and EF and FD make equal angles with AB. By Elementary Geometry we can easily show that DEF is the **pedal triangle**, *i.e.*, D, E, and F are the feet of the \perp s from A, B, C, on the opposite sides.

NOTE 10. — *On Pedal curves.* The locus of P, the foot of a \perp from the origin O on the tangent to a curve is called the **pedal** of the curve

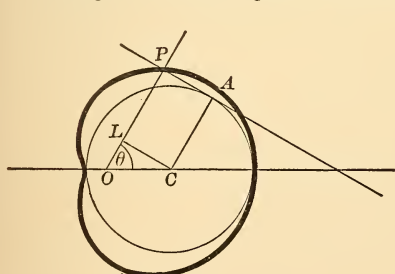

Fig. 164 a

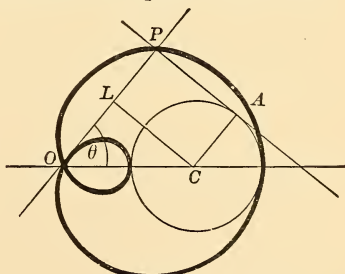

Fig. 164 b

with respect to O , and O is called the **pole** of the pedal. Thus, with respect to a focus, the pedal of an ellipse or hyperbola is the auxiliary circle, and the pedal of a parabola is the tangent at the vertex. We shall now find the pedal of a circle.

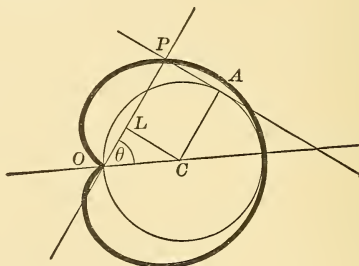

Fig. 164 c

Let C be the center, radius a , and O any point, where $OC = b$.

$$\text{Now} \quad \rho = OP = OL + LP = a + b \cos \theta.$$

$$\therefore \rho = a + b \cos \theta$$

is the polar equation of the pedal; the curve is the Limaçon already mentioned in this book.

The limaçon may be written

$$\rho = \pm a + b \cos \theta$$

corresponding to parallel tangents to the circle. Hence the chord of the limaçon through O is of constant length $2a$.

DISCUSSION of the equation.

(1) If $b > a$, O is **outside** the circle and the pedal is **looped**, having a **double point** O [Fig. *b*].

(2) If $b = a$, O is **on** the circle, and

$$\rho = a(1 + \cos \theta)$$

which is the **cardioid** [Fig. *c*].

(3) If $b < a$, O is **inside** the circle and the pedal consists of a single **oval** curve [Fig. *a*].

This oval has **points of inflexion** if $b > \frac{1}{2}a$.

The limaçon is sometimes called the **conchoid** of the circle because it is described by producing the radius vector of the circle [$\rho = b \cos \theta$] a constant distance a .

The Van Nostrand

Series of

Text Books

12mo, Half Leather

Illustrated

241 Pages

Price \$1.25 Net

Schmall & Shack

“Plane Geometry”

330 Pages

Price \$1.50 Net

Schmall, C. H.

“FIRST COURSE

IN

Analytical Geometry”

290 Pages

Price \$1.50 Net

Cain, Wm. (Prof.)

University of North Carolina.

“BRIEF COURSE

IN THE

Calculus”

OTHER VOLUMES IN PREPARATION.

D. Van Nostrand Company

Publishers and Booksellers

23 MURRAY & 27 WARREN STS.,

NEW YORK

Standard Text Books

PUBLISHED BY D. VAN NOSTRAND COMPANY.

- ABBOTT, A. V.** *The Electrical Transmission of Energy. A Manual for the Design of Electrical Circuits. Fully illustrated. 8vo, cloth.....net, \$5.00*
- ATKINSON, Prof. A. A.** (*Ohio University.*) *Electrical and Magnetic Calculations, for the use of Electrical Engineers and Artisans, Teachers, Students and all others interested in the Theory and Application of Electricity and Magnetism. 8vo, cloth. Illustrated.....net, \$1.50*
- ATKINSON, PHILIP.** *The Elements of Electric Lighting, including Electric Generation, Measurement, Storage, and Distribution. Tenth edition. Illustrated. 12mo, cloth.....\$1.50*
- *The Elements of Dynamic Electricity and Magnetism. Third edition. 120 illustrations. 12mo, cloth.....\$2.00*
- *Power Transmitted by Electricity, and its Application by the Electric Motor, including Electric Railway Construction. Third edition fully revised, new matter added. Illustrated. 12mo, cloth.....\$2.00*
- AUCHINCLOSS, W. S.** *Link and Valve Motions Simplified. Illustrated with 29 wood-cuts, 20 lithographic plates, together with a Travel Scale, and numerous useful tables. Fourteenth edition. Revised. 8vo, cloth.....\$2.00*
- BEAUMONT, ROBERT.** *Color in Woven Design. With 32 colored plates and numerous original illustrations. Thick 12mo.....\$7.50*
- BERNTHSEN, A.** *A Text-Book of Organic Chemistry. Translated by George McGowan, Ph.D. Fourth English edition. Revised and extended by the author and translator. Illustrated. 12mo, cloth.....\$2.50*
- BIGGS, C. H. W.** *First Principles of Electrical Engineering. Being an attempt to provide an Elementary Book for those intending to enter the profession of Electrical Engineering. Second edition. 12mo, cloth. Illustrated.....\$1.00*
- *First Principles of Electricity and Magnetism. A book for beginners in practical work, containing a good deal of useful information not usually to be found in similar books. With numerous tables and 343 diagrams and figures. 12mo, cloth, illustrated.....\$2.00*
- BOWIE, AUG. J., Jun., M.E.** *A Practical Treatise on Hydraulic Mining in California. With Description of the Use and Construction of Ditches, Flumes, Wrought-iron Pipes and Dams; Flow of Water on Heavy Grades, and its Applicability, under High Pressure, to Mining. Ninth edition. Small quarto, cloth. Illustrated.....\$5.00*
- BOWSER, Prof. E. A.** *An Elementary Treatise on Analytic Geometry. Embracing Plane Geometry, and an Introduction to Geometry of three Dimensions. 12mo, cloth. Twenty-first edition.....\$1.75*
- *An Elementary Treatise on the Differential and Integral Calculus. With numerous examples. 12mo, cloth. Twentieth edition.....\$2.25*
- *An Elementary Treatise on Analytic Mechanics. With numerous examples. 12mo, cloth. Seventeenth edition.....\$3.00*
- *An Elementary Treatise on Hydro-Mechanics. With numerous examples. Treatise on Roofs and Bridges. 12mo, cloth. Fifth edition.....\$2.50*
- *A Treatise on Roofs and Bridges. With Numerous Exercises. Especially adapted for school use. 12mo, cloth. Illustrated.....net, \$2.25*
- CATHCART, Prof. WM. L.** *Machine Design. Part I. Fastenings. 8vo, cloth, illustrated.....net, \$3.00*
- CHRISTIE, W. WALLACE.** *Chimney Design and Theory. A Book for Engineers and Architects, with numerous half-tone illustrations and plates of famous chimneys. Second edition, revised. 8vo, cloth.....\$3.00*

- CROCKER, F. B. Electric Lighting.** A Practical Exposition of the Art, for Use of Engineers, Students, and others interested in the Installation or Operation of Electrical Plants. New edition, thoroughly revised and rewritten. Vol. I. **The Generating Plant.** 8vo, cloth.....\$3.00
 — Vol. II: **Distributing Systems and Lamps.** Third edition. 8vo, cloth. Illustrated.....\$3.00
- CROCKER, F. B., and S. S. WHEELER. The Practical Management of** Dynamos and Motors. Fifth edition (Sixteenth thousand), revised and enlarged, with a special chapter by H. A. Foster. 12mo, cloth. Illustrated.\$1.00
- DORR, B. F. The Surveyor's Guide and Pocket Table Book.** Fifth edition. Thoroughly revised and greatly extended. With a second appendix up to date. 16mo, morocco flaps.....\$2.00
- DRAPER, C. H. Heat, and the Principles of Thermo-Dynamics.** With many illustrations and numerical examples. 12mo, cloth.....\$1.50
- ELIOT, Prof. C. W., and STORER, Prof. F. H. A. Compendious Manual of** Qualitative Chemical Analysis. Revised with the co-operation of the authors, by Prof. William R. Nichols. Illustrated. Twentieth edition, newly revised by Prof. W. B. Lindsay and F. H. Storer. 12mo, cloth.....\$1.50
- EVERETT, J. D. Elementary Text-Book of Physics.** Illustrated. Seventh edition. 12mo, cloth.....\$1.40
- FOSTER, H. A. Electrical Engineers' Pocket Book.** With the Collaboration of Eminent Specialists. A handbook of useful data for Electricians and Electrical Engineers. With innumerable tables, diagrams and figures. Third edition, corrected. Pocket size, full leather, 1000 pages.....\$5.00
- FOX, WM., and C. W. THOMAS, M.E. A Practical Course in Mechanical** Drawing, with plates. Second edition, revised. 12mo, cloth.....\$1.25
- GILLMORE, Gen. Q. A. Practical Treatise on the Construction of Roads,** Streets, and Pavements. Tenth edition. With 70 illustrations. 12mo, cloth,\$2.00
- GOODEVE, T. M. A Text-Book on the Steam-Engine.** With a Supplement on Gas-Engines. Twelfth edition. Enlarged. 143 illustrations. 12mo, cloth \$2.00
- GORDON, J. E. H. School Electricity.** Illustrations. 12mo, cloth.....\$2.00
- HAEDER, HERMAN C. E. A Handbook on the Steam-Engine.** With especial reference to small and medium sized engines. Third English edition, re-edited by the author from the second German edition, and translated with considerable additions and alterations by H. H. P. Powles. 12mo, cloth. Nearly 1100 illustrations.....\$3.00
- HALL, WM. S., Prof. Elements of the Differential and Integral Calculus.** Fifth edition, revised. 8vo, cloth. Illustrated.....net, \$2.25
 — **Descriptive Geometry; With Numerous Problems and Practical Applications.** Comprising an 8vo volume of text and a 4to Atlas of illustrated problems. Two vols, cloth.....net, \$3.50
 Postage, 32 cents.
- HALSEY, F. A. Slide Valve Gears, an Explanation of the Action and Construction** of Plain and Cut-off Slide Valves. Illustrated. Eighth edition, revised and enlarged. 12mo, cloth.....\$1.50
- HANCOCK, HERBERT. Text-Book of Mechanics and Hydrostatics.** With over 500 diagrams. 8vo, cloth.....\$1.75
- HERRMANN, GUSTAV. The Graphical Statics of Mechanism.** A Guide for the Use of Machinists, Architects and Engineers; and also a Text-Book for Technical Schools. Translated and annotated by A. P. Smith, M.E. 7 folding plates. Fourth edition. 12mo, cloth.....\$2.00
- JAMIESON, ANDREW, C. E. A Text-Book on Steam and Steam-Engines.** Specially arranged for the Use of Science and Art, City and Guilds of London Institute, and other Engineering Students. Thirteenth edition, revised. Illustrated. 12mo, cloth.....\$3.00
 — **Elementary Manual on Steam and the Steam-Engine.** Specially arranged for the Use of First-Year Science and Art, City and Guilds of London Institute, and other Elementary Engineering Students. Third edition 12mo, cloth.....\$1.50

- JANNETTAZ, EDWARD.** A Guide to the Determination of Rocks: being an Introduction to Lithology. Translated from the French by G. W. Plympton, Professor of Physical Science at Brooklyn Polytechnic Institute. 12mo, cloth,\$1.50
- JOHNSTON, Prof. J. F. W., and CAMERON, Sir CHARLES.** Elements of Agricultural Chemistry and Geology. Seventeenth edition. 12mo, cloth \$2.60
- KAPP, GIBBERT C. E.** Electric Transmission of Energy and its Transformation, Subdivision, and Distribution. A practical hand-book. Fourth edition. Revised. 12mo, cloth.....\$3.50
- KEMP, JAMES FURMAN, A.B., E.M.** A Handbook of Rocks; for use without the microscope. With a glossary of the names of rocks and other lithological terms. 8vo, cloth, illustrated..... \$1.50
- KLEIN, J. F.** Design of a High-speed Steam-engine. With notes, diagrams, formulas, and tables. Second edition, revised and enlarged. 8vo, cloth, illustrated. 257 pages.....net, \$5.00
- LASSAR-COHN, Dr.** An Introduction to Modern Scientific Chemistry, in the form of popular lectures suited to University Extension Students and general readers. Translated from the author's corrected proofs for the second German edition, by M. M. Pattison Muir, M. A. 12mo, cloth, illustrated... ..\$2 00
- LODGE, OLIVER J.** Elementary Mechanics, including Hydrostatics and Pneumatics. Revised edition. 12mo, cloth.....\$1.50
- LUQUER, LEA McILVAINE, Ph.D.** Minerals in Rock Sections. The Practical Method of Identifying Minerals in Rock Sections with the Microscope. Especially arranged for Students in Technical and Scientific Schools. 8vo, cloth. Illustrated.....net, \$1.50
- MILLER, E. H.** Quantitative Analysis for Mining Engineers. 8vo, cloth..... net, \$1.50
- MINIFIE, WM.** Mechanical Drawing. A Text-Book of Geometrical Drawing for the use of Mechanics and Schools, in which the Definitions and Rules of Geometry are familiarly explained; the Practical Problems are arranged from the most simple to the more complex, and in their description technicalities are avoided as much as possible. With illustrations for Drawing Plans, Sections, and Elevations of Railways and Machinery; an Introduction to Isometrical Drawing, and an Essay on Linear Perspective and Shadows. Illustrated with over 200 diagrams engraved on steel. Tenth thousand. With an appendix on the Theory and Application of Colors. 8vo, cloth.....\$4.00
- Geometrical Drawing. Abridged from the Octavo Edition, for the use of schools. Illustrated with 48 steel plates. Ninth edition 12mo, cloth.\$2.00
- MOSES, ALFRED J., and PARSONS, C. L.** Elements of Mineralogy, Crystallography, and Blow-Pipe Analysis from a practical standpoint. 336 illustrations. New and enlarged edition. 8vo, cloth.....\$2.00
- NASMITH, JOSEPH.** The Student's Cotton Spinning. Sixth edition, revised and enlarged. 8vo, cloth, illustrated.....\$3.00
- NUGENT, E.** Treatise on Optics; or, Light and Sight theoretically and practically treated, with the application to Fine Art and Industrial Pursuits. With 103 illustrations. 12mo, cloth.....\$1.50
- ODIN, MAURICE A.** Standard Polyphase Apparatus and Systems. With many diagrams and figures. Third edition, thoroughly revised. Fully illustrated.....\$3.00
- PALAZ, A., Sc.D.** A Treatise on Industrial Photometry, with special application to Electric Lighting. Authorized translation from the French by George W. Patterson, Jr. 8vo, cloth. Illustrated.....\$4.00
- PARSHALL, H. F., and HOBART, H. M.** Armature Windings of Electric Machines. With 140 full-page plates, 65 tables, and 165 pages of descriptive letter-press. 4to, cloth.....\$7.50

- PERRINE, F. A. C., A. M., D. Sc.** Conductors for Electrical Distribution; Their Manufacture and Materials, the Calculation of the Circuits, Pole Line Construction, Underground Working and other Uses. With diagrams and engravings. 8vo, cloth.....net, \$3.50
- PERRY, JOHN.** Applied Mechanics. A Treatise for the use of Students who have time to work experimental, numerical and graphical exercises illustrating the subject, 650 pages. 8vo, cloth.....net, \$2.50
- PLATTNER.** Manual of Qualitative and Quantitative Analysis with the Blow-Pipe. From the last German edition, revised and enlarged, by Prof. Th. Richter, of the Royal Saxon Mining Academy. Translated by Prof. H. B. Cornwall, assisted by John H. Caswell. Illustrated with 87 woodcuts. Eighth edition, revised. 463 pages. 8vo, cloth, net ,.....\$4.00
- POPE, F. L.** Modern Practice of the Electric Telegraph. A Technical Handbook for Electricians, Managers and Operators. Seventeenth edition, rewritten and enlarged, and fully illustrated. 8vo, cloth..... \$1.50
- PRELINI, CHARLES.** Tunneling. A Practical Treatise containing 149 Working Drawings and Figures. With additions by Charles S. Hill, C.E., Associate Editor "Engineering News." Second edition, revised. 8vo, cloth. Illustrated.....\$3.00
- PRESCOTT, Prof. A. B.** Organic Analysis. A Manual of the Descriptive and Analytical Chemistry of Certain Carbon Compounds in Common Use; a Guide in the Qualitative and Quantitative Analysis of Organic Materials in Commercial and Pharmaceutical Assays, in the Estimation of Impurities under Authorized Standards, and in Forensic Examinations for Poisons, with Directions for Elementary Organic Analysis. Fifth edition. 8vo, cloth..... \$5.00
- **Outlines of Proximate Organic Analysis, for the Identification, Separation, and Quantitative Determination of the more commonly occurring Organic Compounds.** Fourth edition. 12mo, cloth.....\$1.75
- **First Book in Qualitative Chemistry.** Twelfth edition. 12mo, cloth.net, \$1.50
- **and OTIS COE JOHNSON.** Qualitative Chemical Analysis. A Guide in the Practical Study of Chemistry and in the Work of Analysis. Fifth fully revised edition, entirely re-written. With Descriptive Chemistry extended throughout. 8vo, cloth.....net, \$3.50
- RANKINE, W. J. MACQUORN, C. E., LL.D., F.R.S.** Machinery and Millwork. Comprising the Geometry, Motions, Work, Strength, Construction, and Objects of Machines, etc. Illustrated with nearly 300 woodcuts. Sixth edition. Thoroughly revised by W. J. Millar. 8vo, cloth.....\$5.00
- **The Steam-Engine and Other Prime Movers.** With diagram of the Mechanical Properties of Steam. With folding plates, numerous tables and illustrations. Thirteenth edition. Thoroughly revised by W. J. Millar. 8vo, cloth.....\$5.00
- **Useful Rules and Tables for Engineers and Others.** With appendix, tables, tests, and formulæ for the use of Electrical Engineers. Comprising Submarine Electrical Engineering, Electric Lighting, and Transmission of Power. By Andrew Jamieson, C.E., F.R.S.E. Seventh edition. Thoroughly revised by W. J. Millar. 8vo, cloth..... \$4.00
- **A Mechanical Text-Book.** By Prof. Macquorn Rankine and E. F. Bamber C.E. With numerous illustrations. Fourth edition. 8vo, cloth.....\$3.50
- RANKINE, W. J. MACQUORN, C.E., LL.D., F.R.S.** Applied Mechanics. Comprising the Principles of Statics and Cinematics, and Theory of Structures, Mechanics, and Machines. With numerous diagrams. Fourteenth edition. Thoroughly revised by W. J. Millar. 8vo, cloth.....\$5.00
- **Civil Engineering.** Comprising Engineering Surveys, Earthwork, Foundations, Masonry, Carpentry, Metal-Work, Roads, Railways, Canals, Rivers, Water-Works, Harbors, etc. With numerous tables and illustrations. Twenty-first edition. Thoroughly revised by W. J. Millar. 8vo, cloth.....\$6.50
- REINHARDT, CHAS. W.** Lettering for Draughtsmen, Engineers & Students. A Practical System of Free-hand Lettering for Working Drawings. New and revised edition. Thirteenth thousand. Oblong boards.....\$1.00

- RICE, Prof. J. M., and JOHNSON, Prof. W. W.** On a New Method of Obtaining the Differential of Functions, with especial reference to the Newtonian Conception of Rates of Velocities. 12mo, paper..... \$3
- RIPPER, WILLIAM.** A Course of Instruction in Machine Drawing and Design for Technical Schools and Engineer Students. With 52 plates and numerous explanatory engravings. 4to, cloth..... \$6.00
- SEVER, Prof. G. F.** Electrical Engineering Experiments and Tests on Direct-current Machinery. With diagrams and figures. 8vo, pamphlet, illustrated..... net, \$1.00
- SHELDON, Prof. S., Ph. D., and HOBART, MASON, B. S.** Dynamo Electric Machinery; its Construction, Design, and Operation. Direct-current Machines. Fourth edition, revised. 8vo, cloth. Illustrated..... net, \$2.50
- **Alternating Current Machines.** Being the second volume of the author's "Dynamo Electric Machinery; its Construction, Design, and Operation." With many diagrams and figures. (Binding uniform with volume I.) Third edition. 8vo, cloth. Illustrated..... net, \$2.50
- SHIELDS, J. E.** Notes on Engineering Construction. Embracing Discussions of the Principles involved, and Descriptions of the Material employed in Tunneling, Bridging, Canal and Road Building, etc. 12mo, cloth..... \$1.50
- SNELL, ALBION T.** Electric Motive Power; The Transmission and Distribution of Electric Power by Continuous and Alternate Currents. With a section on the Applications of Electricity to Mining Work. 8vo, cloth. Illustrated..... \$4.00
- STAHL, A. W., and WOODS, A. T.** Elementary Mechanism. A Text-Book for Students of Mechanical Engineering. Eleventh edition. Enlarged. 12mo, cloth..... \$2.00
- STALEY, CADY, and PIERSON, GEO. S.** The Separate System of Sewerage; its Theory and Construction. With maps, plates, and illustrations. Second edition. 8vo, cloth..... \$3.00
- SWOOPÉ, C. WALTON.** Practical Lessons in Electricity. Principles, Experiments and Arithmetical Problems. An Elementary Text-Book. With numerous tables, formulæ and two large instruction plates. Fourth edition. 8vo, cloth. Illustrated..... net, \$2.00
- URQUHART, J. W.** Dynamo Construction. A practical handbook for the use of Engineer Constructors and Electricians in charge, embracing Framework Building. Field Magnet and Armature Winding and Grouping, Compounding, etc., with examples of leading English, American, and Continental Dynamos and Motors; with numerous illustrations. 12mo, cloth..... \$3.00
- WEISBACH, JULIUS.** A Manual of Theoretical Mechanics. Ninth American edition. Translated from the fourth augmented and improved German edition, with an Introduction to the Calculus by Eckley B. Coxe, A. M., Mining Engineer. 1,100 pages, and 902 woodcut illustrations. 8vo, cloth..... \$6.00
Sheep..... \$7.50
- WESTON, EDMUND B.** Tables Showing Loss of Head Due to Friction of Water in Pipes. Second edition. 12mo, cloth..... \$1.50
- WILSON, GEO.** Inorganic Chemistry, with New Notation. Revised and enlarged by H. G. Madan. New edition. 12mo, cloth..... \$2.00
- WRIGHT, Prof. T. W.** Elements of Mechanics, including Kinematics, Kinetics, and Statics. Third edition, revised and enlarged. 8vo, cloth..... \$2.50



JUN 28 1965

McCord's

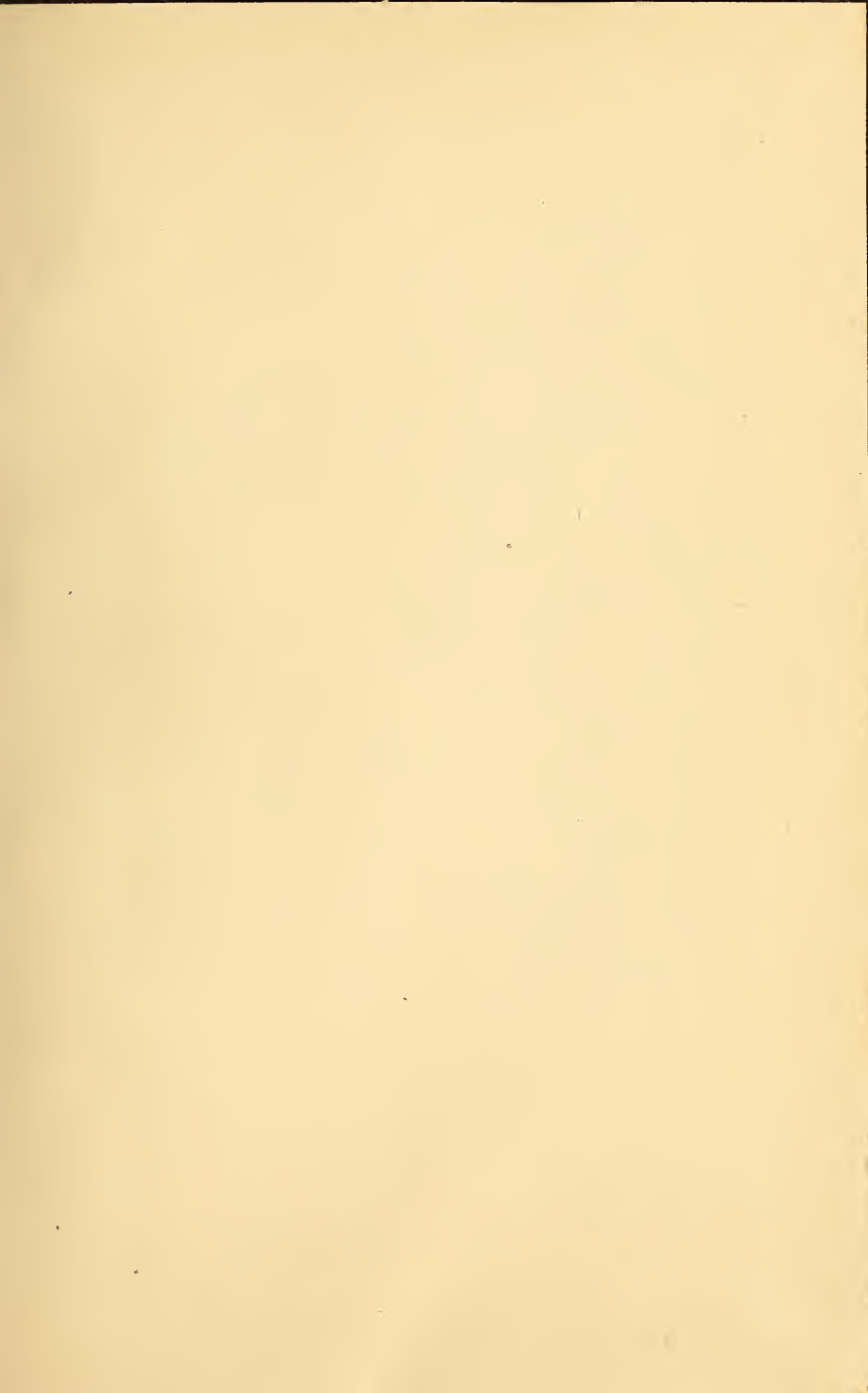





LIBRARY OF CONGRESS

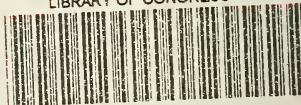

0 003 559 784 0